



G<9FKCC8:B8IGHF:9G:G'5B'9BJ:FCBA9BH5@@M'F9GDCBG:6@9'7CAD5BM'H<-G'A5BI5@:G'DF:BH98'CB'F97M7@98'D5D9F'
D@95G9'99D'H<9G9'BGHFI7H-CBG:CF:IHI F9'F9:9F9B79



? cXJU
K ccX'Grcj Y

BY: SHERWOOD INDUSTRIES LTD

@H? 6C'D > 2? F 2=

Models: 1200 & 1700 Insert and 1200 & 1700 Fireplace Freestanding



-BGH5@@9F . ''@Uj Y'h'lg'a Ubi U'k Jh'h'Y'k ccX'grcj Y"
7CBGI A 9F . FYHJb'h'lg'a Ubi U'Zcf'Zi hi fY'fYZfYbW"

7cbhUWfnci f''cWU'Vi J'X]b['cf'UfY'cZUM]Ug'cf'h'Y'Ui h'cf]m\Uj]b['i f]gX]M]cb'
UWci hfYgfh]M]cbg UbX]bghU'Uh]cb]bgdYV]cb fYei]fYa Ybhg]b'nci f'UfYU"

D@95G9'F 958 'H<=G'9BH'F 9'A 5BI 5@69: CF 9'BGH5@@5H-CB'5B8'I G9'C: 'H<=G'K CC8'
6I FB=B; 'FCCA '<95H9F'": 5=@ F9'HC: C@CK 'H<9G9'BGHFI 7H-CBG'7CI @8'F 9GI @H'
=B'DF CD9F HM85A 5; 9'Z'6C8=@M=B> FMCF '9J 9B'895H"



H'lg'\YUHYf'a YHYg'h'Y'I "'G''9bj]fcb'a YbHJ'DfchV]cb'5[YbV]Yg'
Ya]gg]cb''ja]hg'Zcf'k ccX'\YUHYfg'gc'X'UZHYf'>i' m'p'gh'z%' - '\$"
I bXYf'gdYV]UWV]bX]h]cbg'h'lg'\YUHYf'\Ug'VYb'g'ck b'hc'XY'j Yf'
\YUhiUhfUHYg'fUb[]b['Z'ca '%z(+ - 'hc' (Z%' * '6HI 'dYf'\ci f'Zcf'
h'Y'&\$\$ UbX'Z'ca '- z(&) 'hc' %z+, '\$'6HI 'dYf'\ci f'Zcf'h'Y'&\$\$"

) \$!%\$(\$

HUV`Y`cZ`7`c`b`h`Y`b`h`g

GUZYImDFYWI h]cbg.....
CdYfU]b[`=bgf] V]cbg.....(
6i]X]b[`Mti f` :]fY.....*
5]f` 7cb]fc.....-
<ck `=h`K cf_g.....%\$
GdYV]U]Vh]cbg.....%8/
%&\$` GdYV]U]Vh]cbg.....%8/
%+\$\$` GdYV]U]Vh]cbg.....%&
7YUfUbWg`Hc`7ca Vi gh]VYg!`%&\$`=bgYfh.....%
7YUfUbWg`Hc`7ca Vi gh]VYg!`%+\$\$`=bgYfh.....%
7YUfUbWg`Hc`7ca Vi gh]VYg!`%&\$` : fYYghUbX]b[.....%
7YUfUbWg`Hc`7ca Vi gh]VYg!`%+\$\$` : fYYghUbX]b[.....%*
8]a Ybg]cbg!`%&\$`=bgYfh.....%+
8]a Ybg]cbg!`%&\$`=bgYfh.....%
8]a Ybg]cbg!`%&\$` : fYYghUbX]b[.....%
8]a Ybg]cbg!`%+\$\$` : fYYghUbX]b[.....&\$
 : fYYghUbX]b[`G]XY`8]a Ybg]cbg : cf : Ub`?]h.....&/%
=bg]U`Uh]cb.....&&
FYa cj U` : fca `DU`Yh.....&&
DYXyghU`=bg]U`Uh]cb!` : fYYghUbX]b[.....&&
@[g`5bX`5g`Dub`=bg]U`Uh]cb!` : fYYghUbX]b[.....&
=bg]U`Uh]cb`CZ<YUH`9Z]V]bVh]G\]YX!` : fYYghUbX]b[: `Uh]Hcd.....&
AcX]U]Vh]cbg : cf`=bg]U`Uh]cb`k]h`% ` f(, - a a E<][\ `@]b]hY!`=bgYfh.....&(
<YUfH`Dfch]V]cb`9]Ua`d`Yg.....&
Ci`hg]XY`5]f`?]h.....&
FYV]a a YbYX`<Y][\hg : cf : `i`Y`D]dY.....&
7\]a bYm`=bg]U`Uh]cb`H\]fci [\ `K`U.....&-
=bg]U`Uh]cb`cZ5`@ghYXz : U]V]cfm]6i]h7\]a bYm!` : fYYghUbX]b[.....\$
A Ugc]b]fm :]fYd`UW`=bg]U`Uh]cb!` : fYYghUbX]b[.....`
AcV]Y`<ca`Y`=bg]U`Uh]cb.....`
A Ugc]b]fm :]fYd`UW`=bg]U`Uh]cb!`=bgYfh.....`)
Gi`f]fci`bX`DubY`GYU`YX`=bg]U`Uh]cb : cf`I`G5`Cb`m!`=bgYfh.....` +
=bg]U`Uh]cb`I`g]b[`5`6`cW!`CZD`UH` : cf`I`G5`Cb`m!`=bgYfh.....` ,
AcXY`%&\$`6f]W`D`UW`a`Ybh/`H`VY`@cW]h]cbg.....`(\$
AcXY`%+\$\$`6f]W`D`UW`a`Ybh/`H`VY`@cW]h]cbg.....`(%
8ccf`=bg]U`Uh]cb.....`(&
7Yf]Ua]W6UZ]Y`=bg]U`Uh]cb.....`('
 : Ub`K`]f]b[`8]U[f]Ua`g.....`('
Cd]h]cbU` : Ub`=bg]U`Uh]cb!` : fYYghUbX]b[.....`()
 : Ub`FYa`cj`U`!`=bgYfh.....`()
FYa`cj`U`CZH`Y`G\]fci`Xg!`=bgYfh.....`(*
=bg]U`Uh]cb`CZH`Y`8YV]f]U]h]Y`D`UH`g!`=bgYfh.....`(*
=bg]U`Uh]cb`CZH`Y`Gi`f]fci`bX`DubY`!`=bgYfh.....`(+
DUf]hg`@gh.....`(
DUf]hg`8]U[f]Ua`!` : fYYghUbX]b[.....`)\$
DUf]hg`8]U[f]Ua`!`DYXyghU`g/`@[g.....`)%
DUf]hg`8]U[f]Ua`!` :]fYd`UW`=bgYfh.....`)&
K`Uf]U]b]h]m.....`)'
=bg]U`Uh]cb`8U]U`G\]Yh.....`)*

GUZYhmDf YWUi h]c b g

: CF`G5: 9`-BGH5@@5H-CB`5B8`CD9F 5H-CB`C: `MCI F`Î9BJ`-FCİ`K CC8`
GHCJ 9ž`D@95G9`75F 9: I`@@MF 958`H< 9: C@@CK`-B;`-B: CFA 5H-CB.

D`YUgY`fYUX`h`jg`Ybh]fY`a Ubi U`VYZcfY`nei`]bghU`UobX`i gY`nei f`bYk`k ccXg]cj Y": U]i fY`hc`
Zc`ck`]bghfi V]cbg`a UmfYgi`h]b`dfcdYf]mXUa U[Yž`VcX]m]b`f fmcf`Yj Yb`XYUH`"6Y`Uk UfY`
h`Uh`cW`7cXYg`UbX`FY[i`Uh]cbg`a Umcj`Yff]XY`gca Y`]h`a g]b`h`jg`a Ubi U`"7\`YW`k`]h`nei f`
`cW`]bgdYV]cf"

-Z`h`jg`Udd`]UbW`]g`bch`dfcdYf`m]bghU`YXž`cdYfUHYX`UobX`a U]b]U]bYXž`U`gYf]ci g`ci gY`UfY`Vti`X`fYgi`h`
8c`bchi gY`Ubmia U`Yg\`žna UHYf]Ug`Xi`f]b[]bghU`Uh]cbž`a U]b]b]UbWž`cf`fYd`UW`a Ybh`

BYj`Yf`d`UW`k`ccXž`d`UdYfž`ž`fb]h`fYž`XfUdYg`cf`ch`Yf`Vta`Vi`gh]V`Y`a`UHYf]Ug`bYUf`h`Y`g]cj`Y`"8c`bch`Yh`
W]XfYb`cf`dYhg`hci`W`]hk`\`Yb`]h]g`\`ch`

CdYfUHY`cb`mk`]h`h`Y`Xccf`UbX`Ug`d`Ub`h]`h`m`Vc`gYX`UobX`Vi`fb`k`ccX`X]fYV]mcb`h`Y`g]cj`Y`\`YUf`h`"8c`
bchcdYfUHY`]Z`h`Y`Xccf`[`Ugg`]g`Vfc`_`Yb`cf`U`[`Ug`_`Yh]g`a`]gg]b[`cf`XUa`U[`YX`"8c`bch`UHYf`h`Y`Vta`Vi`gh]cb`
U]f`Vt]bfc`j`Uj`Yg`"8`Ub[`Yfci`g`cj`YfUf]b[`Vti`X`cWVf`k`\`W`Vti`X`][`b]h`VfYcgch`]b`h`Y`W]a`bYmcf`
W]i`gY`U`\`ci`gY`UfY`"

5h`YUgh`%&`gei`UfY`]bWYg`f]h`+"(`Vt`&L`cZ`ZYg`ci`hg]XY`U]f`g`ci`X`VY`UXa`]hYX`]bhc`h`Y`fcca`cf`X]fYV]mi`
hc`h`Y`g]cj`Y`h`fci`[\`U`(`]bW`f]b`\$`%`Vt`L`X]Ua`YhYf`d]dY`":`cf`h`Y`g]cj`Y`hc`cdYfUHY`Vta`Vi`gh]cb]U]f`a`i`gh`
VY`gi`dd]YX`h`fci`[\`Y]h`Yf`h`Y`Vchca`cf`h`Y`VUW`cZ`h`Y`dYXYghU`"

8c`bch`Vi`fb`Vt`U`cf`WUfVt`U`Ug`h`YfY`]g`XUb[`Yf`cZ`WfVcb`a`cbcl`]XY`VY]b[`dfcXi`WX`"8c`bch`i`gY`
WY`a`]W`U`i`]Xg`hc`ghUf]hcf`fY]ZYg`h`Y`UfY`"8c`bch`Vi`fb`[`UfVU[`Y`cf`U`Ua`a`U`Y`U`i`]Xg`gi`W`Ug`[`Ugc`]bYž`
[`fYUgYž`bUd`h`U`cf`Yb[`]bY`c]"BYj`Yf`Yh`h`Y`g]cj`Y`VYVta`Y`\`ch`Ybci`[\`hc`[`Yh`UbmidUf]h`fYX`cf`[`ck`]b[`
fYX`"

6i`fb]b[`k`Yž`i`bgYUgcbYX`k`ccX`Vti`X`W]i`gY`Yi`Wgg]`Y`VfYcgch`UWV`a`i`Uh]cb`]b`h`Y`U`i`Y`d]dY`"K`\`Yb`
][`b]hYXž`]h`Vti`X`W]i`gY`U`W]a`bYmUfY`h`Uh`Vti`X`fYgi`h]b`U`gYf]ci`g`ci`gY`UfY`"

8c`bchi`gY`[`fUHYgž`UbX]fcbg`cf`Ubmch`Yf`a`Yh`cXg`hc`gi`ddcf]hcf`fU]gY`h`Y`UfY`i`d`cZ`h`Y`\`YUf`h`cZ`h`Y`
Udd`]UbW`"

H`jg`Udd`]UbW`]g`hYghYX`hc`I`@!`G*`+`GHUbXUFX`Zcf`GdUW`<YUHYfg`Zcf`I`gY`k`]h`Gc`]X`:`i`Yž`I`@!`G*`&`
GHUbXUFX`Zcf`:]fYd`UW`-bgYf]gž`/`I`@%(`,`&`GHUbXUFX`Zcf`GUZYhmZcf`Gc`]X!`:`i`Y`HdY`Fcca`<YUHYfg`"

6ch`h`Y`%&\$\$`/`%+\$\$`:]fYd`UW`-bgYf]g`UfY`Uddfcj`YX`Zcf`]bghU`YX`]bhc`U`nYfc!`WUfUobW`UfYd`UWg]b`h`Y`
I`"G`-b`7UbUXU`fYZYf`hc`cW`Vi`]X]b[`cf`UfY`cZ]U]Ug`Zcf`fYgh]V]cbg`UbX`]bghU`Uh]cb`]bgdYV]cb`
-b`7UbUXU`h`Y`Yi`]gh]b[`W]a`bYmia`i`gh`VY`]bYX`hc`h`Y`hYfa`]bUh]cb`Zcf`U`a`Ugcbfm]bghU`g`"

=ADCFH5BH`h`Y`Zc`ck`]b[`a`i`gh`VY`XcbY`
hc`Ybgi`fY`dfcdYf`cdYfU]cb`":U]i`fY`hc`Xc`gc`
k]"W]i`gY`Yi`fY`a`Y`cj`Yf`YU]b[`UobX`dcgg]VY`
dYfgcbU`]b`f`fmcf`dfcdYf]mXUa`U[`Y`
i`-Z`Ub`ci`hg]XY`U]f`gi`dd`m`Ug`bch`VYYb`UXXYX`hc`
h`jg`Udd`]UbWž`d`YUgY`Ybgi`fY`h`Uh`h`Y`(`]bW`
ZYg`U]f`ci`h`Yh`cb`h`Y`VUW`cZ`h`Y`dYXYghU`]g`
fY`a`cj`YX`"
i`9bgi`fY`h`Uh`h`Y`Ug`\`Xi`a`d`[`fUHY`UobX`Vtj`Yf`
d`UHY`UfY`]bghU`YX`cj`Yf`h`Y`Ug`\`Xi`a`d`\`c`Y`"

| | | |
|---|---|---|
|  NATIONAL FIREPLACE INSTITUTE | We recommend that our woodburning hearth products be installed and serviced by professionals who are certified in the U.S. by the National Fireplace Institute® (NFI) as NFI Woodburning Specialists or who are certified in Canada by |  |
|  CERTIFIED www.nficertified.org | | |
| Wood Energy Technical Training (WETT). | | www.wettinc.ca |

C dYf Uh]b [' =bghf i Wh]c bg

: =FGHGH5FH

K \Yb Üfgh]bghU'YXž' h.Y'W]a bYnä'ÜFVf]Wg'UbX'ghY'ÜFY'W'X'UbX']hi gi U'miU_Yg'g]Y'YfU'\ci fg'cb'U'Z]f'mi
 \] \Vi fb'Zcf'hYa'hc'VY'W'a Y'\ch'UbX'Xfm'Ybci [\Zcf'h.Y'g'rcj Y'hc'Z' bW]cb'k'Y'"K'Y'fY'W'a a YbX'Xi f]b['
 h.Y'i b]Hj'Üfgh'Vi fb'h.Uh'U'Xccf'UbX'k']bXck'ÜFY'cdYbYX'hc'j Ybh'h.Y'ga c_Y'UbX'Z' a Yg'VY'U'Y'Z'fca' h.Y'
 i b]Hj'dU]bh'W'f]b["'h.Y'dU]bh'k']'ga Y'"U']h.Y'Zcf'h.Y'Üfgh'Vi fb'cf'k'c'Ug']h'W'fYg'

: 5BG

5'' a cXY'g' \Uj Y' VYb' Uddfcj YX' Zcf' cdYfU]cb' k]h' cf' k]h'ci h' h.Y' cdh]cbU' Z]bg' gi dd']YX' Vm' h.Y'
 a Ubi ZUM' fY' Cb'a YX]i a 'cf' \] \Vi fbgž' i g]b['U' Z]b' k']']bWY'UgY' h.Y' \YU'h'f'U'bgZ]f' g] \h'm' Fci h' h.Y'
 dck Yf' gi dd'm'W'f'X'U'cb['h.Y'Üccf'VY']bX' h.Y'g'rcj Y'k' \YfY']h'k']'fYa U]b'W'c''

8=GDCG5@C: '5G< 9G

=Zmci 'Yh'h.Y'Ug'Yg'UWW'a i 'U'Y'k'c'cf'h'fY']bWY'g'cb' h.Y'Üccf'h'Y'm'h'Y'bX'hc'Vi fb'h.Ya g'j' Ygi d''
 h.Y'Üfyd'UW']bgyf'ha cXY'g'Xc' bch'Uj Y'UbX'Ug' Xfuk Yf'gc' h.Y'Ug'Yg'k']'bYX'hc' VY'g'W'cdYX']bhc' U'a YHU'
 W'ebU]bYf'k']h' U'h] \h'm'Üh]b[']X' D'UW' h.Y'W'cgYX' W'ebU]bYf'cb' U' bcb! W'a Vi gh'VY'Üccf'k' Y'"Uk UmZ'fca'
 W'a Vi gh'VY'a U'Yf]Ug'

h.Y'ZFY'g'U'X]b[' a cXY'g'ÜFY'Yei]ddYX'k']h' U'ga U''h'ud'Xccf']b' h.Y'Üfyvcl' UbX'Ub'Ug' Xfuk Yf' CdYb'
 h.Y'f'ud'Xccf' c'W'YX'cb' h.Y'Üccf'cZ
 h.Y' i b]h' Di g' h.Y'Ug'Yg' h.Uh' \Uj Y'
 UWW'a i 'U'YX']bhc' h.Y' \c'Y' k'YfY' h.Y'
 Ug'Yg'k'ci 'X' X'fcd']bhc' h.Y'Ug' d'Ub''
 9bgi fY' h.Uh' h.Y'f'ud'Xccf']g' W'cgYX'
 dfcdYf'm' VYZ'fY' fY'] \h]b[' h.Y' i b]h'
 K \Yb' h.Y'Ug' Xfuk Yf']g' fYUX'm'hc' VY'
 Ya dh]YX']zh'h.Y'Z'cbhc'Z' h.Y'Xfuk Yf' i d'
 h.Yb'g'ck' mdi '' h.Y'Xfuk Yf'gh'U] \h'ci h'
 UbX' W'cgY' h.Y']X' cb' h.Y'Ug' Xfuk Yf'
 fgyY' :]i fY' %&' h']g']g' hc' dfY' Ybh'
 a U_]b[' U' a Ygg'k']h' h.Y'Ug'Yg'k' \Yb'
 f'U'bgdcf]b[' h.Y'Ug' Xfuk Yf' h'fci [\'
 h.Y' \ci gY'' K \Yb' fY!]bgh'U']b[' h.Y'Ug'
 Xfuk Yf' Ybgi fY' h.Uh' h.Y']X']g' cdYb' UbX'
]bY' i d' h.Y' fU]g'cb' h.Y'Vcl'ca' cZ' h.Y'
 Ug' Xfuk Yf' k']h' h.Y' bch'WY'g']b' h.Y'
 cdYb]b['cb' h.Y'dYX'Yg'U' fgyY' :]i fY' &'
 G]XY' h.Y'Xfuk Yf']bhc' d'UW'ž' h.Y'Z'cbhc'Z'
 h.Y'Xfuk Yf'k']' X'fcd' U'V]h'k' \Yb']h']g' U'
 h.Y'k' Um]b''

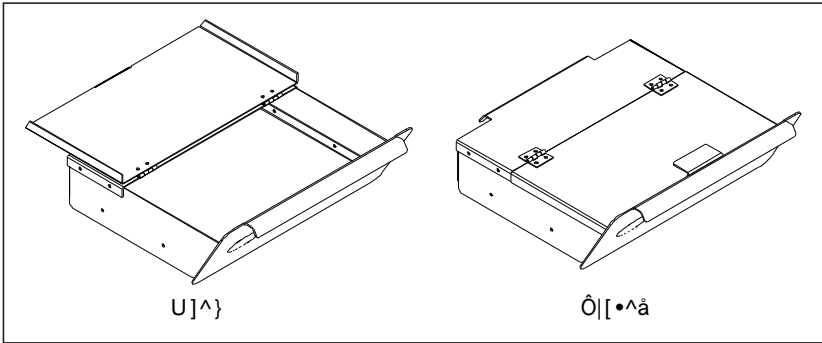

:]i fY' % 5g' 8fuk Yf' @]X' CdYb' UbX' 7'cgY''

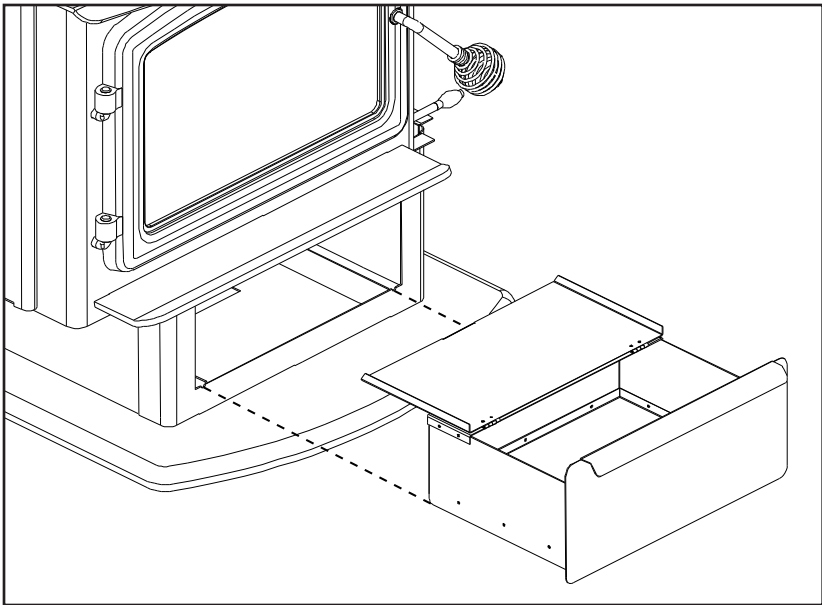

:]i fY' & ' =bgh'U']b[' 5g' 8fuk Yf''

=Z h.Y'Ug'Yg'ÜFY'hc' VY'Vi f]YX']b'gc']'cf'
 ch'Yfk']gY' c'W' m'X]gdYfgYXž' _YYd' h'Ya'
]b' U' W'cgYX' W'ebU]bYf' i bh']' U' V]bXY'fg'
 \Uj Y' W'c'YX'' Ga U'' Ua ci bhg' cZ' W'c'
 k'ccX' Ug' W'b' VY' i gYX']b' h.Y' [ÜfXYb'
 cf' W'a d'cgh'

C dYf Uh]b [' =bghf i Wh]c b g

F9D@57=B; 'H<9; @5GG.

BYj Yf'grf]_Y'cf'gUa 'hY'Xccfz\]h'hY' ['Ugg'cf'Yh'Vi fb]b['k ccX'fYghU[U]bgh]h' =Z'hY' ['Ugg'VWUW'g'k \Yb' hY'UfY'j'g'Vi fb]b[z'Xc'bhcdYb'hY'Xccf'i bh]'hY'UfY'j'g'ci h'UbX'Xc'bhcdYfU'hY'g'hcj'Y'U[U]b'i bh]'hY' ['Ugg'\Ug'VYb'fYd'UWX''=Z'hY' ['Ugg]g'XUa U[YX'j'b'Ub'mik U'h'U'ZUM'c'f'm'fYd'UW'a Ybh]g'f'Yei]fYX'f'g'Y'f' D5FHG' @Gh'L''Hc'fYa cj'Y'hY'Xccf'z'cdYb'UbX''j'h' Hc'fYd'UW'hY' ['Uggz'fYa cj'Y'hY'g'hY'fYhU]b]b['W]dg'UbX'U''ccgY' ['Ugg'fYd'UW'cb'mik]h'BYcWfUa ') 'a a ['Ugg'%''*%â'f(&&'a a L'I '%\$''* 'Î f&+\$'a a L'UbX'k fUd'hY' YX[Yg'k]h' '\$"%&) 'Î f' "&a a L'I '\$') 'Î f%' 'a a L'g'Y'ZUX\Yg]j'Y'U'VYf['Ugg[U'g_Y'h'

K YUf' ['cj'Yg'k \Yb' \UbX'j]b['XUa U[YX' ['Ugg'Xccf'UggYa V'm'hc' d'fYj'Ybh'dYfgcbU''j]b'f'm'i K \Yb' hY' ['Ugg'Xccf'UggYa V'm]g'VY]b['f'Ubgdcf'hY'Xz']h'a i gh'VY'k fUddYX'j]b'bYk gdf]bh'UbX'hUdY'UbX'#cf'U'g'f'cb['d'Ugh]WU] ['' hY' ['Ugg'a i gh'VY'di fWUgYX'Z'fca 'Ub'9BJ =F C XYUYf''Bc'g' Vgh]h' h' a UHf]Ug'UfY'U'ck YX''

7@95B=B; 'H<9'D@5H98'G'F: 579G.

DU]bhY'X'ZUM'g'g'ci 'X'VY'k]dYX'k]h' U'XUa d'Wc'h' dYf]cX]W'n'i =Z'U'd'UHY'X'ccf'\Ug'VYb'di fWUgYXz']h' g'ci 'X'VY'i bdUWYX'WfYz' 'm'hc'Uj'c]X['Y'h]b['Ub'm'h]b['cb'hY'g'i fZUM'cZ'hY'Ub]g'z'j]b'W'X]b['WU'UbYfgz' dc]g'UbX'Ub['Y'f'df]b'g'h' 'h]g]a dcf'f'Ub'h'c' bch' h'U'h'Ub['Y'f'df]b'g'UbX'ch'Y'f'a Uf_g'WU'YUj'Y'U'dYfa UbYbh' gU]b'cb'd'UHY'Ub]g'Yg''Hc'Uj'c]X'h'g'z' []Y'hY'ZUM'U'ei]W'k]dY'k]h' XYbU'h'fYX'U'Wc'c'cb' U'gcZ'h'Wc'h' 69: CF9'' [\h]b['hY'UfYd'UW''BYj Yf'WU'Ub'hY'Xccf'k \Yb'j]h]g'\ch' 8c'bchi gY'ch'Y'f' WU'UbYfg'Ug'hY'mia Um'YUj'Y'U'fYg]Xi Yz'k \]W'WU'VY'W'a Y'dYfa UbYbh'mY'h'WYX'j]b'hc'hY'g'fZUM''

: =F9'9LH=B; I =G<9F'5B8'GAC?9'89H97H=CB.

5''\ca Yg'k]h' U'gc'X'Z'Y'Vi fb]b['g'hcj'Y'g'ci 'X'\Uj'Y'U'h'YUgh'cbY'UfY'Yi h]b[i]g\Y'f'j]b'U'W'bh'U''c'W'h]cb' _bck'b'hc'U''j]b'hY'\ci gY'c'X'UbX'U'ga c_Y'XYH'W]cb'XYj]gY'j]b'hY'fcca 'Wc'bhU]b]b['hY'g'hcj'Y''=Z]h'gci bXg' hY'U'Ufa z'Wc'f'fY'h' hY'W] gY'Vi h'Xc'bh'XYUW]j]h' M'i 'a Um'W'ccgY'hc'fY'c'W'h' hY'ga c_Y'XYH'W]cb' XYj]gY'k]h'j]b'hY'fcca /8C'BC'H'F9A Cj'9'H<9'GAC?9'89H97HCF': FCA 'H<9'FCCA''

7F9CGCH9! =HG: CFA5H=CB'5B8'F9ACJ5@

K \Yb'k ccX'j]g'Vi fbYX'g'ck 'n'z']h'a Um'dfcXi W'fUf'UbX'ch'Y'f'j'Udcfg'h'U'h'z'W'a V]bYX'k]h' 'a c]g'h'fYz'Z'fca 'WY'cgch'' hY'YgY'j'Udcfg'Wc'bXYbgY'j]b'hY'fY'U'h]j'Y'm'Wc'Y'f'W]a bYm'U'i Y'cZ'U'g'ck'Vi fb]b['UfY'UbXz'jZ'] [b]hY'Xz'a U_Y'Ub'Yi f'fYa Y'm'\ch'UfY'' hY'fY'Z'fYz'hY'ga c_Y'd]dY'UbX'W]a bYm'g'ci 'X'VY'j]b'gd'Y'W'X'V]! k YY'_mXi f]b['hY'\YU'h]b['gY'U'gcb'hc'XY'h'fa]bY'jZ'U'Vi]X'i d'\Ug'c'W'f'fYX'' =Z'WY'cgch'\Ug'UW'W'a i 'UHY'X']h'g'ci 'X'VY'fYa cj'YX'hc'fYXi W'hY'f]g'_cZ'U'W]a bYm'UfY''

7<=AB9MCF'FI B'5K 5M: =F9.

%''7U''c'W'UfY'XYdUf'a Ybh'f'cf'X]U''-%&

&''7'cgY'hY'XfUz'h]z' 'm

' ''9'Ua]bY'hY'U'i Y'd]dYg'z'W]a bY'n'z'U'h]W'UbX'fccZ'cZ'hY'\ci gYz'hc'gY'jZ'Ub'm'dUf'h'\Ug'VY'W'a Y'\ch' Ybci ['\hc'WU'W'UfY''=Z'bY'W'gg'U'f'n'z'gdf'Umik]h'UfY'Yi h]b[i]g\Y'f'cf'k UH'f'Z'fca 'hY' [UfXYb'\cgY''

(' ''8c'bchi cdYfU'h' hY'g'hcj'Y'U[U]b' i bh]'m'ci 'UfY'W'f'U]b' hY'W]a bYm'UbX'j]g'j]b]b['\Uj'Y' bchi VYb' XUa U[YX''

C dYf Uh]b [' =bghf i Wh]c bg

A5=BH9B5B79.

5hH'Y'YbX'cZYUW' \YU]b['gYUgcb'WU'Ub'h'Y'W]a bYmUbX'h'Y'ga c_Y'd]dY"'=Zgcch\Ug'UW]a i 'UH'X'U'Vcj Y' h'Y' h'cd'VU'Z]Y'Vf]W]g'z'fYa cj Y'z'WU'bz'UbX'h'Y'b'fY'd'UW'h'Ya "'=Z'h'Y'g'Y'W'zbXU'fmU]f' h' VY']g'VUX'm'Y'fc'XY'X'z' fY'd'UW']h'F'Y'd'UW'k'cfb'X'ccf' [Ug_Y'rg'UbX'V'fc_Y'b'Vf]W]g'Ug'b'Y'Y'X'X"'

: 5=@ F 9'HC' =BGD97H'5B8'7@95B'MCI F'7<=A B9MGMGH9A' F 9; I @5F @M75B'F 9GI @H' =B'5' 7<=A B9M: =F 9'Z'K <=7<'7CI @B'85A 5; 9'H<97<=A B9MCF'75I G9'5'<CI G9: =F 9'

6i =@B=B; 'M: i F': =F 9.

DfcdYf'cdYfUh]cb'cZ'nci f'g'rcj Y'k]''\Y'd'hc'Y'bgj fY'g]Z]Y'Z]M]Y'bh\YU]b["'D'YUg'Y' h_U'Y'U'Z'Yk' 'a ca Y'bhg'hc' fY]]Yk' h'Y'gY'g]a d'Y'cdYfUh]b['dfc'WXi' fYg'

%': i Y'GY'VM]cb.

H\]g'g'rcj Y']g'XYg][bYX'hc'Vi fb' bUhi fU'k'ccX'cb'm' <][\Yf'Y'Z]M]Y'bh\YU]b['U'X' 'ck Yf'Ya]gg]cbg' [YbYfU'm' fYg' h'k \Yb'Vi fb]b['U]f'X]Y'X'gYUgcbYX' \U'f'X'k'ccX'g'z'Ug'V'ta dU'f'Y'X'hc'gc'Z'k'ccX'g'cf'hc' [fY'Y'b'cf'Z'f'Y'g' m'W'h' \U'f'X'k'ccX'g'8C' B'CH'6i' F'B' h'Y'Z'c'ck]b[. 'h'Y'U'Y'X'k'ccX'z'V't'U'z' [U'f'VU']Y'z'gc'j Y'bh'g'z'V't'cf'Y'X'd'U'd'Y'f'g'z'cf' h'f'U'g' "' 6i fb]b['h'Y'gY'a Um'f'Y'g' 'h]b'h'Y'f'Y'Y'U'gY'c'Z'h'cl]W]Z' a Y'g'UbX'a Um'dc]g'cb'cf'f'Y'b'X'Y'f'h'Y'W'U'U'm]W]b'Y'Z'Y'W]j'Y"' 6i fb]b['V't'U'z'W'f'X'V'c'U'f'X'z'cf''ccgY'd'U'd'Y'f'W'U'b'd'f'c'X'i' W'g'c'h'z'cf''U'f' [Y'U'U'Y'g'c'Z'W'U'f'cf'U'm'U'g' h'U'h'W'U'b'V't'U'hi h'Y'V't'a Vi g'rc'f'z'W'U'i'g]b['ga c_Y'gd]'U' [Y']b'hc' h'Y'f'cca'z'UbX'f'Y'b'X'Y'f]b['h'Y'V't'a Vi g'rc'f']b'Y'Z'Y'W]j'Y"'

&"6i]X]b[#A U]b]U]b]b['U':]fY.

U'c'dYb'h'Y'df]a U'fmU]f'g]X'Y'V'mdi '']b[']h'U''h'Y'k'Um'hc'h'Y'f][\h'

V't'D'U'W'U'V'U'gY'c'Z'W'i' a d'Y'X'i' b'V't'cf'Y'X'b'Y'k'gd'U'd'Y'f']b'h'Y'V'c'h'ca' c'Z'h'Y'g'rcj Y"'@U'md]Y'W'g'c'Z']b'X']b['cb' h'cd'c'Z'h'Y'b'Y'k'gd'U'd'Y'f'UbX''][\h'h'

75I H=CB. 'I B'Y'j'Y'f'i' gY' [U'g'c']b'Y'z' [U'g'c']b'Y'! h'm'd'Y''Ub'h'f'b'z' Y'z'_Y'f'c'g'Y'b'Y'z'W'U'f'V't'U''][\h'Y'f'U'i']X'z' cf'g]a]U'f'']ei']X'g'hc'g'U'f'h'cf' 'I'Z'f'Y'g'Y'b'i' d'I' U'U'f'Y']b'h']g'\Y'U'h'f''?Y'Y'd'U''g'j' W'']ei']X'g'k'Y'' Uk'Um'z'f'ca' \Y'U'h'f'k' \]Y']h']g']b' i' gY''

W'5'g'h'Y']b'X']b['VY']b'g'hc'Vi fb'z'U'X'g'Y'Y'fU''U'f' [Y'f'd]Y'W'g'c'Z'k'ccX'i' bh' h'Y'U'f'Y']g'Vi fb]b['k'Y'' 5h'h']g' dc]b'h'z'fY' [i' U'f'g]h'Y''c']g'a Um'VY'U'X'X'Y'X''

BCH9. 'I bh' h'Y'U'f'Y']g'Vi fb]b['k'Y''z'Y'U'j'Y'h'Y'U]f'V't'bf'c'g'z' ''mcdYb''

X'L'F'Y' [i' U'h'Y'h'Y'\Y'U'hc'i' h'di' h'c'Z'h'Y'g'rcj Y'V'm'U'X'1'g]h]b['h'Y'U]f'V't'bf'c'g'hc'U'ck'U'U'f' [Y'f'U'f'Y'Ub'X'j']W'j'Y'f'gU'' 5'g'lc'f'h'd'Y'f'c'X'c'Z'Y'i' d'Y'f']a' Y'b'U'h]c'b'k']h' h'Y'V't'bf'c'g'Y'h]b['g'k']''U'ck' 'nci' hc'fY' [i' U'h'Y'h'Y'\Y'U'hc'i' h'di' h' hc'_Y'Y'd'nci' f'\ca' Y'V't'a' Z'cf'U'V'Y''

8c'bchi' gY'U' [f'U'h'Y'cf'Y'Y'j' U'h'Y'h'Y'U'f'Y'' 6i']X'k'ccX'U'f'Y'cb'h'Y'g'rcj Y'U'f'V'cl' \Y'U'f'h'U'ccf''

' "F'Y'Z' Y']b['h'Y'G'rcj Y.

I'gY'U'cb['d'U]f'c'Z' [c'j'Y'g'f'U'f'V'Y'W'Y' [c'j'Y'g'k' \Y'b'Z'Y'X']b['h'Y'U'f'Y'V'Y'W'i' gY'h'Y'gY'g'rcj Y'g'Vi fb'U'hi'h'Y'Z'f'cb'h' h'Y'm'U'f'Y'W'U'Ub'X'Y'Z]M]Y'bh'Vi' h'h'Y'm'U'f'Y'U'g'c'j'Y'f'm'\ch'Ub'X' [c'j'Y'g'U'f'Y' i' gY'Z' ''?Y'Y'd'U'ga' U''g'h'Y'Y'g'c'j'Y' Ub'X'k' \]g'_b'Y'U'f'V'm'Z'cf'a'c'j']b['U'c' [cf'']z]b['U'Z'U'Y'b'Ya' V'Y'f'Ub'X'Z'cf'_Y'Y'd']b['h'Y'\Y'U'f'h'W'U'Ub''

U'c'6'Y'Z'c'f'Y'U'h'Y'a' d]h]b['hc'U'X'X'z'Y'hc'h'Y'g'rcj Y'z'CD9B'h'Y'X'U'a' d'Y'f'V't'bf'c'z' ''m'V'mdi'']b[']h'U''h'Y'k'Um'ci' h' h']g'U'ck'g'h'Y'W]a' b'Y'm'hc'W'f'f'm'U'k'Um' h'Y'U'X'X']h]c'b'U'ga' c_Y'z'k' \]W'c'W'W'f'g'k' \Y'b'h'Y'X'ccf']g'cd'Yb''

V't'8C' B'CH'c'j' 9F @C58' H<9'GHCJ 9''B'c'f'a' U'n'a' h'f'Y'Y'cf'Z'ci' f'c' [g'k']''df'c'j']X'Y'\Y'U'h'Z'cf'g'Y'Y'f'U'\ci'f'g'' B'Y'j'Y'f'cd'Y'f'U'h']g'g'rcj Y'k' \Y'f'Y'd'c'f'h]c'bg' [ck'f'Y'X'\ch'

C dYf Uh]b [' =bghf i Wh]c bg

W'8C'BCH'CJ 9F: =F 9" =Z\h.Y\YUhf'cf'W]a bYmVtbbYVtcf' [`ck gž'nci 'UFY'cj YfUf]b["

XŁ:75I H=CB. '8C'BCH'D@579': I 9@K =H<=B'GD579' <95H9F' =BGH5@@5H=CB'7@95F5B79G'CF'K =H<=B' H<9'GD579'F9EI =F 98': CF'7<5F; =B; '5B8'5G<'F9A CJ5@.

(": cf'A U]a i a '9ZUVYbVth

K \Yb'h.Y'g'cj Y']g\chž`cUX']hZ' `m'hc' h.Y'rcd'cZ\h.Y'Xccf'cdYb]b['UbX'Vi fb'Uha YX']i a `ck' gYH]b[g"K \Yb' h.Y'Z' Y']g'a cghmVtbg' a YXž'YUj]b['U'VYX'cZ'fYX' VtUgž'fYdYU'h.Y'dfcWgg" 'A U]a i a ' \YU'hZcf'a]b]a i a ' Z' Y' cWVf'g'k \Yb' h.Y' g'cj Y' rcd' h'a dYfU'h' fY']g' VYrk Yyb' &) \$š: 'f!&\$š7Ł' UbX')) \$š: 'f!&- \$š7Ł' h.Y' a cgh']_Y'mVt' gYg' cZ'X'f'm['Ugg'UFY. 'bchYbci [\ 'Z' Y' hc' [Y'h'h.Y' g'cj Y' h.cfc[[\ 'm\chž'Vi fb]b[' [fYyb'cf'k Yh' k ccXž'Vt'g]b['h.Y' XfUzh' bh' h.Y'fY']g']bg' ZUVYbh'U]f' Zcf' Vt'a d'Y'h' Vt'a Vi g]cbž'cf' U'k YU_ 'W]a bYmXfUk " =bXYYXž'h.Y'WVubYgg'cZ'h.Y' ['Ugg']g' U' [ccX']bX]Vtcf'cZ'h.Y' g'cj Y' cdYfU]b['YZUVYbh'm

<YdZ' `<]bhg]K cfh' F YdYU]b[':

%" <YdZ' `UX]]W' cb' h.Y' VtffYVt'k Uritc' g]Ufhnci' f'UFY"

UŁ: M'i' k]' bYX' ga U' d]YVWg' cZ' Xfmk ccXž' W'YX']_bX']b[ž' UbX' dUdYf' " I gY' cb'mbYk gdUdYf' cf' dUdYf' h.Uh\Ug' bchVYyb' VtUHYX' cf' \UX' ch.Y'f' a UHf]Ug' ['i YX' cf' Udd']YX' hc']h' BYj Yf' i gY' VtUHYX' f'm[]W' m' UX] Yfh]g]b['U'nyfg'cf' Vt'ci fYX' dUdYf'

VŁ: 5'k Uhg' cdYb' h.Y' Xccf' cZ' h.Y' k ccX' g'cj Y' g'ck' m'hc' d'fY' Ybh' gi V]cb' UbX' XfUk]b[' ga c_Y']bhc' h.Y' fcca "

WŁ: 7'fi a d'Y' gY' YfU' d]YVWg' cZ' dUdYf' UbX' d'UW' h.Y'a ']b' h.Y' WbhYf' cZ' h.Y' UfYVcl' 'UbX' X]fYVt'micbhc' h.Y' UfYVf]W]g' cZ' h.Y' k ccX' g'cj Y' " BYj Yf' i gY' U' [fU'h' hc' Y'Yj U'h' h.Y' UfY"

XŁ: D'UW' ga U' d]YVWg' cZ' Xfmk ccX' f_]bX']b[Ł'cj Yf' h.Y' dUdYf']b' U' h'YdYYI' a UbbYf' h\]g' U'ck' g' Zcf' [ccX' U]f' V]V' U'h]cbž'k \]W']g' V]h]W' Zcf' [ccX' Vt'a Vi g]cb"

YŁ: @ [\h'h.Y' V] a d'YX' dUdYf']b' &cf' " `cVU]cbg' BchY. ' =h]g']a dcfUbh'hc' \YU'h'h.Y' U]f']b' h.Y' g'cj Yd]dY' Zcf' XfUzh'hc' g]Ufh'

ZŁ: i `m'cdYb' h.Y' U]f' Vt'bfrc'g' cZ' h.Y' k ccX' g'cj Y' UbX' Vt'gY' h.Y' Xccf' i bh']h]g'g'] [\h'm'cdYbž' U'ck']b[' Zcf' a i W' bYXXYX' U]f' hc' VY']b'f'cXi WX']bhc' h.Y' UfYVcl' " BYj Yf' YUj Y' h.Y' Xccf' Z' `m'cdYbž' Ug' gdUf' _g' Z'ca' h.Y']_bX']b[' a Um'Umici' hc'Z'h.Y' g'cj Yž'W]i' g]b[' XUa U' [Y'cf']b' t' fr' 5'g' h.Y' UfY' VY []bg' hc' Vi fb' h.Y']_bX']b[ž' gca Y' UXX']_cbU']_bX']b[' a Um'VY' bYXXYX' hc' gi g]U]b' h.Y' UfY' " 8C' BCH' UXX' a cfY' dUdYf' UZ'Yf' h.Y' UfY' \Ug' g]UfhYX"

[Ł' CbW' h.Y']_bX']b[' \Ug' g]UfhYX' hc' Vi fbž' UXX' gca Y' ga U' Yf' d]YVWg' cZ' gYUgcbYXž' Xfm' UfYk ccX' " BchY. ' 5XX]b[' Uf' [Y' d]YVWg' U'h'h.Y' YUf' mg]U' [Ygk]' cb' mgYf] Y' hc' ga ch.Y'f' h.Y' UfY' " 7cb]bi Y' UXX]b[' ga U' d]YVWg' cZ' gYUgcbYX' Xfm' UfYk ccXž' _Yd]b[' h.Y' Xccf' g'] [\h'm'cdYb' i bh' YUW' d]YVW' g]Ufhg' hc'] [b]hY' " FYa Ya VYf' hc' U'k Uhg' cdYb' h.Y' Xccf' g'ck' m'VYrk Yyb' d'U]b[' k ccX']bhc' h.Y' UfY"

\ Ł' CbW' h.Y' k ccX' \Ug' g]UfhYX' hc'] [b]hY' UbX' h.Y' ga c_Y' \Ug' fYX' WXž' Vt'gY' h.Y' k ccX' g'cj Y' Xccf' Z' `m' h.Y' fYXi V]cb' cZ' ga c_Y']g' U' [ccX']bX']W]cb' h.Uh'h.Y' XfUzh']b' h.Y' W]a bYm\Ug' g]UfhYX' UbX' [ccX' Vt'a Vi g]cb']g' bck' 'dcgg]V'Y' " @U]f' Yf' d]YVWg' cZ' gYUgcbYXž' Xfm' UfYk ccX' W]b' bck' 'VY' UXXYX' k \Yb' h.Y'fY']g' gi ZUVYbh' gdUW']b' h.Y' UfYVcl' " 5X' t' gh' h.Y' U]f' Vt'bfrc' gYH]b[' hc' XYg]fYX' gYH]b[" BchY. ' h.Y' `ck' Yf' h.Y' U]f' Vt'bfrc' gYH]b[ž' h.Y' `cb [Yf' h.Y' Vi fb' h]a Y' cZ'nci' f' UfYk ccX"

&"K \Uh'mdY'cZk ccX']g'VYgh'hc' i gY' Ug' UfYk ccX3

6ch' \UfXk ccX' UbX' gcZ'k ccX' Vi fb' k Y']']b' h']g' g'cj Y' " 6ch' k ccXg' Vt'bh]U]b' U'Vci h, žššš' 6HI #V' f% ž) +\$? >#? [Łž' Vi h' \UfXk ccX']g' [YbYfU' ma cfY' XYbgYž' k]' k Y [\ ' a cfY' dYf' Vt'fXž' UbX' Vi fbg' U']h'Y' g'ck' Yf' UbX' `cb [Yf' 7i H]b[' UfYk ccX' gc' h.Uh']h'k]' 'Uh' \cf']ncbU' nā Z'cb'hc' VUWž' a U_Yg']h'YUg]Yf' cUX]b[' UbX' Ygg']_Y'm Zcf' h.Y' Z' Y' hc' fc' `cb' h.Y' ['Ugg' " 9I Wdhi Zcf' U' Vt' X' g]Ufhž' h.Y'fY']g' bc' bYXX' hc' W]g]g' Vt'cgg' h.Y' `c [g' =YU'

C dYf Uh]b [' =bghf i Wh]c bg

Yb[h' Zcf' hY' c[gi' gYX']b' hY' %&\$\$ k ci' X' VY' UVci h%* í fl , %a a E' Vi h] h' Vb' Vi fb' d] YWgi d' hc' % í ' cb["'
=>YU' ' Yb[h' Zcf' hY' c[gi' gYX']b' hY' %+\$\$ k ci' X' VY' UVci h% í fl , %a a E' Vi h] h' Vb' Vi fb' d] YWgi d' hc' &\$í'
' cb[' c[g' ' 6i fb' cb' m' Xfná' gYUgcbYX' k ccX' " =h' d' fcXi Wg' a cfY' \ YUh' UbX' ' Ygg' gcch' cf' VYcgchY' " : fYg\ m' W' h'
k ccX' \ Ug' UVci h) \$í ' a c] gh' fY' " 5' %\$' dci bX' f(") ? [E' c[' Vá' bhU]bg) ' dci bXg' f& " ? [E' cZk UHY' " Hc' gYUgcb'
ÚFYk ccX' Z' gd'] h' UbX' g' hU'] h' gc' h' Uh' U] f' Vb' [Yh' hc' U' ' dUf' hg' cZ' h' Y' k ccX' " 6i fb' VYUW' ' k ccX' ' cb' m'] Z'] hg' g' U' h'
Vá' bh' bh' \ Ug' VYyb' k Ug' YX' Uk' Um] b' U' gYUgcb' cZ' fU] b' UbX' h' Yb' h' Y' k ccX' Xf' YX' " Hc' d' fYj Ybh' ga c_ Y' gd'] U[Y'
k \ Yb' fYz' Y'] b[z' cdYb' h' Y' Xccf' g' ck' m'

' "K \ Uh' XcYg' Xfná' gYUgcbYX' k ccX' a YUb3

K ccX' h' Uh' \ Ug' VYyb' Xf' YX' Zcf' U' dYf' cX' cZ' cbY' mYUf'] b' U' k Y' ! j Ybh' UHY' X' UbX' g' Y' h' fYX' UfYU' k ci' X' VY'
Vá' bg] XYfYX' Xfná' gYUgcbYX' k ccX' " K ccX' Z' fca' ' g' ck' ! [fck'] b[' h' fYg'] g[YbYfU' m' Vá' bg] XYfYX' VYh' Yf' h' Ub' k ccX'
Z' fca' Z' Ugh' [fck'] b[' h' fYg'] Hc' gYUgcb' ÚFYk ccX' Z' gd'] h' UbX' g' hU'] h' gc' h' Uh' U] f' Vb' [Yh' hc' U' ' dUf' hg' cZ' h' Y'
k ccX' "

("K] ' Zc' ck] b[' h' Y' Uwcj Y!] ghY' ghYdg' Zcf' g' hUf] b[' U' ÚfY' a YUb' dYfZ' Vá' fYg' ' hg' Yj Yfmi] a Y3

H' Y' ei] W' U' bgk Yf'] g' la' cgh' cZ' h' Y' h] a Y' H' h' YfY' UfY' a Ubmj Uf] UV' Yg' h' Uh' a Um' UZZ' Vá' nci' f' gi' W' Wgg' k \ Yb'
g' hUf] b[' U' ÚfY' " A' cgh' cZ' h' cgY' j Uf] UV' Yg' UbX' \ ck' ' hc' X' YU' k] h' h' Ya' k] ' VY' ' YUfbYX' h' fci [\ YI' dYf' YbW' "
Má' f' Uv']] m' hc' g' hUf] U[' ccX' ÚfY' k] ' g[b] U' Vá' bh' m] b' VY' UgY' k] h' h] a Y' UbX' d' Uf] YbW' " Gca' Y' cZ' h' Y' fYUgcbg' Zcf'
d' cc' f' g' hcj Y' dYfZ' fca' UbW' k] ' VY' Vá' j YfYX'] b' h' Y' bYI' h' gY' Vá' cb' cZ' h' YgY'] b' g' h' f' Vá' cbg' "

) "K \ m' Vb' B= [Yh' h' Y' ÚfY'] h3

8Ua' d' cf' k Yh' k ccX' UbX' d' cc' f' XfUz' hg' UfY' h' Y' a U] b' fYUgcbg' Zcf' d' cc' f' fYg' ' hg'] b' g' hUf] b[' U' ÚfY' " 5' k Uhg' i' gY'
Xfná' gYUgcbYX' k ccX' Zcf' nci' f' ÚfY' " 9j Yb' k ccX' Xf' YX' Zcf' h' c' mYUf' g' k] ' VY' X' Z' U' W' h' hc'] [b] h'] Z'] h' \ Ug' VY' Vá' a Y'
k Yh'

* " =g] h' b' c' f' a U' Zcf' g' c' ch' hc' Vá' j Yf' h' Y' [' Ugg' U' h' h' Y' VY' [] b] b[' cZ' U' ÚfY' 3

Má' f' g' hcj Y' \ Ug' VYyb' Vi] h' k] h' Ub' U] f' k Ug' \ g' n' g' h' Ya' ' h' Uh' k] ' \ Y' d' ' _YYd' h' Y' [' Ugg' W' WUf' k \ Yb' h' Y' ÚfY' Vcl'
\ Ug' fYUW' YX' U' [ccX' cdYfU] b[' h' Ya' dYfU' h' fY' UbX' \ Ug' U' [ccX' XfUz'] B' c' f' a U' m' U' \ c' h' g' hcj Y' k] ' _YYd' h' Y' [' Ugg'
W' WU' b' z' Vi h'] Z' nci' ' a' i' gh' W' WU' b' h' Y' [' Ugg' z' i' gY' U' g' c' Zh' Vá' h' k] h' h' bc' U' V' fUg] Y' UbX' W' WU' b' cb' m' k \ Yb' Vá' X' " 7c' X'
ÚfY' Vcl' ' h' Ya' dYfU' h' fY' UbX' d' cc' f' XfUz' h' W' i' gY' g' c' ch'] b[' cZ' h' Y' [' Ugg' " CbW' h' Y' ÚfY' Vcl' ' h' Ya' dYfU' h' fY' UbX' h' Y'
XfUz' h' b' VY' UgYz' h' Y' g' c' ch' k] ' Vi fb' cZ'

+ "K \ Uh'] g' XfUz' 3

8fUz' h' g' h' Y' Uv']] m' cZ' h' Y' W'] a bYm' hc' YI' \ Ui' gh' cf' XfUk' ' ga c_ Y' d' fcXi WX' Xi f] b[' h' Y' b' c' f' a U' Vá' a Vi g' h' cb'
d' fc' W' gg' " Hc' c' a' i' W' XfUz' a Um' W' i' gY' YI' W' gg' j Y' h' Ya' dYfU' h' fYg'] b' h' Y' Udd'] UbW' UbX' a Um' XUa U[Y' h' Y'
Udd'] UbW' " =bUX' Yei UHY' XfUz' a Um' W' i' gY' VUW' di Z' Ub[' cf' í' d' i [[] b[í' cZ' h' Y' W'] a bYm' h' YfY'] g' U' W' fU] b'
Ua' ci' bh' cZ' XfUz' h' Uh'] g' fYei] fYX' hc' U' ck' ' Zcf' nci' f' g' hcj Y' hc' Z' b' Vá' cb' U' h'] hg' D'] [\ Ygh' YZ' U' W' Yb' W' h' 5' k UHYf'
Vá' i' a' b' [U[Y' W' b' VY' i' gYX' hc' fYZ' fYbW' h'] g' Ua' ci' bh'

, "K \ Uh' Vb' W' i' gY' U' d' cc' f' XfUz' 3

H' Y' a' cgh' Vá' a' cb' Z' U' W' c' fg' Zcf' d' cc' f' XfUz' UfY.
U' k' 5] f' g' dd' m'
Vá' 9b] j' f' c' b' a Yb' h' U' Vá' b' X'] h' c' b' g'
Vá' 7c' X' W'] a bYm' h' Ya' dYfU' h' fY
X' k' D' cc' f' W'] a bYm'] b' g' h' U' U' h'] c' b' UbX' a U] b' h' Yb' UbW'
Y' k' 5' h' a' c' gd' \ Yf'] W' d' f' Y' g' j' fY

C dYf Uh]b [' =bghf i Wh]c bg

Uk' 5]f' gj dd'mE' =bg]XY' hY' \ca Yz' bcfa U' \ci gY\c'X' Udd']UbWg' gj W' Ug' VcH'Yg' XfnYfg' UbX' ZcfWX! U]f' Z' fbUWg' Vta dYH' Zcf U]fz' fYg' 'h]b[']b' U]f' ghUfj Uh]cb' hc' hY' UfY' H\]g' VYUHYg' U' VzbX]h]cb']b' hY' \ci gY' _bck' b' Ug' bY[Uh] Y' dfYggi fY' " K \Yb' U' \ci gY' Yl dYf]YbWg' bY[Uh] Y' dfYggi fYz' hY' Vta Vi gh]cb[[UgYg' VUb' VY' XfUk' b' Z'ca' hY' V\]a' bYm]UbX']bhc' hY' \ci gY' H\]g' VzbX]h]cb']g' Vta a' cb'miFYZYffYX' hc' Ug' Xck' b! XfUZh]b[" =bVYUgYX' Ua' ci bhg' cZ']bgi' Uh]cbz' j']bm' k']bXck' gZ' Yl fFU' VU']b[']b' j' U]f]c' g' d'UWg' UbX' Xccf' gYUg' WUb' U' _YYd' \YUh']b' Vi' h' a' UmUgc' a' U_Y' U' \ca' Y' hc' U]fh] \H' " 5b' YUgmik' Umhc' g'gcd' bY[Uh] Y' dfYggi fY']b' U' \ca' Y']g' hc' VUW' U' k']bXck']b' hY' fcca' VzbH]b]b[' hY' g'rcj' Y"

Vk' 9bj']fcb' a' YbHU' 7cbX]h]cbg! '<][\ fYfYgZ' ck! 'n]b[\ci gY' cW]h]cb' gi' W' Ug']b' U' j' U' Ynā' HU' Vi']X]b[g' cf' gh] VU' fYg' gi' f'cci' bX]b[' nci' f' \ci gY' UbX' k']bXmVzbX]h]cbg' WUb' WU' gY' dccf' XfUZh'cf' Xck' b! XfUZh]b["

Wk' 7c'X' 7\]a' bYm]HYa' dYfUhi' fY' !' 5j' c]X' Vt' X' W\]a' bYm]HYa' dYfUhi' fYg' VmVi' fb]b[' U' \ch' UfY' Zcf' hY' Ufgh' UZH' Yb' hc' Zcfmia']bi' hYgZ' VY]b[' WUfYZ' ' bch' hc' 'cj' Yf! UfY' hY' g'rcj' Y' " =Z' UbmidUfh' cZ' hY' V\]a' bYm]cf' dUfhg' cZ' hY' g'rcj' Y' ghUfh' hc' [' ck' z' nci' UfY' 'cj' Yf! Uf]b[' hY' g'rcj' Y' " K \YfY' d'cgg]VYz']bgrU' U' h' Ya' dYfUhi' fY' [U' [Y' cb' hY' V\]a' bYm]gc' h' Ya' dYfUhi' fY' X' fcdg' WUb' VY' g'Yb"

Xk' 7\]a' bYm]bgrU' Uh]cb' UbX' A' U]bhY' bUbW' !' 5j' c]X' i' g]b[' hc' a' Ubm]Y' Vck' g'cf' cb[\cf]ncbHU' fi' bg' Hc' g'lc' fh' U' V\]a' bYm]WUb' WU' gY' X]ZUW' h' ghUfh' i' dz' X]f' m[' Uggz' VUW' ga' c']b[' k' \Yb' Xccf']g' cdYbz' UbX' Y' j' Yb' fYX' i' WX' \YUh' ci' hdi' h' Hc' HU' U' V\]a' bYm]a' Umidfca' dh' Yl' Wgg] Y' XfUZh' k' \]W' WUb' fYg' 'h]b' j' Yfm]g' c' fh' Vi' fb' h]a' Yg' UbX' Yl' Wgg] Y' \YUh' ci' hdi' h' =Z']b' Xci' Vrz' VzbHU' m] U' V\]a' bYm]Yl' dYfhi' UbX' #cf' W\]a' bYm]a' Ubi' ZUW' fYf' Zcf' \Yd' " 7' YUb' W\]a' bYm]rā' fU]b' WUdg' UbX' Ygd' YVU' m] hY' gd' Uf' _' Uf' fYg'rcf' fY[i' Uf' nā' hc' d'fYj' Ybh' VY' cgch' Y' Vi']X' i' dz' k' \]W' k']' g] [b] U' WUb' h' m] fYX' i' W' V\]a' bYm]X' fUk' UbX' d'cgg]V' m] U' V\]a' bYm]UfY"

BchY. hY' Yg']bgrfi' W]cbg' UfY']bhY' bXYX' Ug' Ub' U]X' UbX' Xc' bch' gi' dYfWXY' Ubm]c' WUz' d'fcj']bVU' cf' ghUHY' fYei']fYa' Ybhg' " 7' \YW' k']h' c' ZUW' g' cf' U' h' cf']h]Yg' \Uj']b[' f']gX]W]cb']b' nci' f' UfYU"

5=f 7CBHf c@

H\]a' U]f' k' Ug' UbX' d]ch]U]f' fVzb]fc' hY' Ua' ci' bhicZ' U]f' hc' hY' UfY' UfY' Vzb]fc' YX' Vm]hY' fcX' c' WUHYX' cb' hY' f] [\hg]XY' cZ' hY' i' b]h' Hc']bVYUgY' nci' f' U]fz' di' " hY' fcX' ci' h' UbX' hc' XYVYUgYz' di' g' hY' fcX']b' " 5' hY' i' b]hg' \Uj' Y' U' gY' VzbXUf' m] U]f' h' U' h' Uck' g' h' fci' [\ hY' h' VYg' U' h' hY' hc' d' cZ' hY' UfY' Vcl' z' f' gh' VY' ck' hY' VUzU' Yg"

Di' " h\]g' Vzb]fc' U' hY' k' Umci' h' k' \Yb' Ufgh' ghUfh]b[' hY' g'rcj' Y' " CbW' hY' UfY' \Ug' VYYb' YghU']g' YX' nci' ' a' Um]UX' f' gh' h\]g' Vzb]fc' hc' gYh' hY' Vi' fb' fUHY' cZ' hY' UfY' " =Z' h\]g' XUa' dYf']g' Vt' gYX' U' h' Ufgh' ghUfh' i' dz' hY' UfY' k']' Vi' fb' j' Yfm]g' ck' m] UbX' Vt' X' g' cch' hY' Udd']UbW"

K \Yb' g' Vi' h]b[' Xck' b' hY' g'rcj' Yz' Z' m' cdYb' hY' U]f' Vzb]fc' " H\]g' U' ck' g' hY' V\]a' bYm]HYa' dYfUhi' fYg' hc' fYa' U]b' Ug' \] [\ Ug' d'cgg]V' Y' Zcf' Ug' cb[' Ug' d'cgg]V' Y' " 7c'X' W\]a' bYm]HYa' dYfUhi' fYg' VYUHY' VY' cgch' Y"

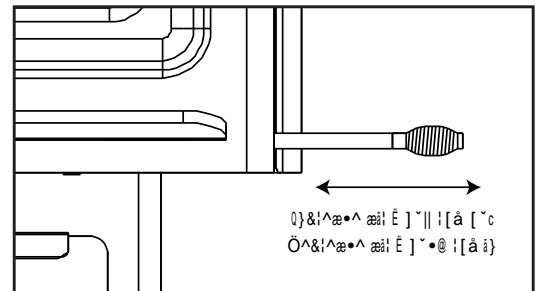

: [i fY' . '5]f' 7cb]fc' FcX"

C dYf Uh]b [`=bghf i Wh]c bg

<CK `≠HK CF?G.

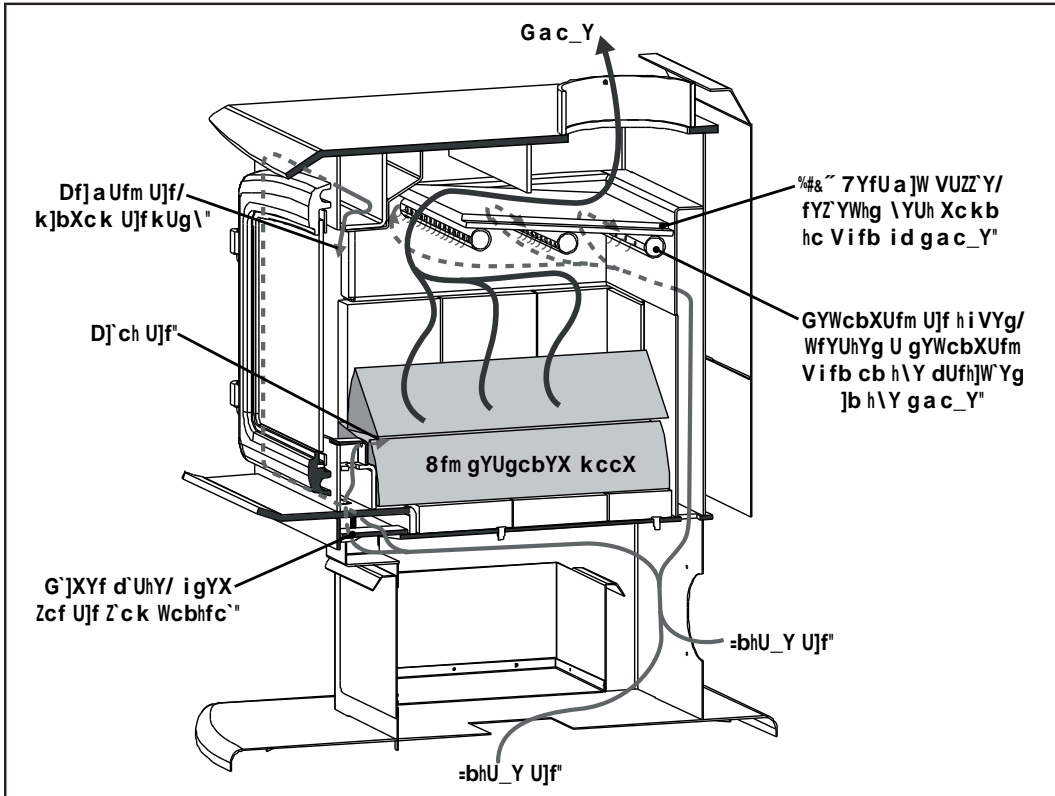

:][i fy`(. %&\$\$ `5]f: `ck `DUh` "

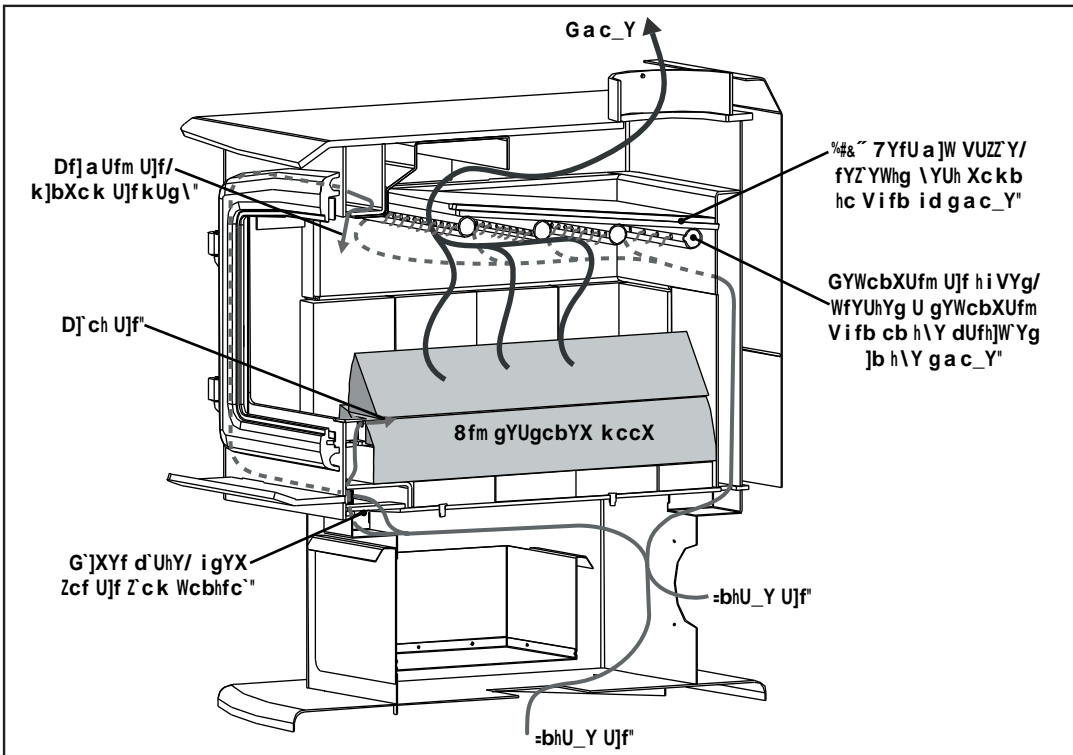

:][i fy`. %+\$ \$ `5]f: `ck `DUh` "

G dYW]Z]WU]c b g

%+\$ \$GD97 = 75H-CBG.

HUVY & %+\$ \$; YbyfU`-bZcfa U]cb"

| AcXY` | %+\$ \$: fYYgU]b[| | %+\$ \$-bgYfh |
|--|--|----------------------------|--|
| | :`Uh]cd | GHyd`Hcd | |
| K]Xh`I`8Ydh | &)^I`I`&*`%#%I`f*)`a a`I`*, (`a a`I` | | &+`I`I`&^I` fI+\$)`a a`I`**`\$`a a`I` |
| <Y][\hk]h`dYXYgU`cf`Y[g | &`I`I` fI+%`a a`I` | `%`I`I` fI-(`a a`I` | |
| <Y][\hcZVcXm | %`I`I` f(` `a a`I` | &%`I`I` f)(\$`a a`I` | |
| :]fY`Vcl`g]hY` fKYdh`I`k]Xh`I` \Y][\H | &\$**)^I`I`%`&)^I`I`%`-)^I`f) &)`a a`I`(` `a a`I`"(\$`a a`I` | | |
| 7UdU]hm | &)`ZYh`I`f`\$+\$, `a YHf`I` | | |
| f`5ddfcl`ja UH`\YU]b[`UFYU | %\$\$\$!`&Z&\$\$\$ZYH&fI`&-`I`&\$)`(` `a YHf&I` | | |
| f`9"D'5""ci`hdi`h]fU]b[| -Z(&)`hc`I`%Z+, `\$6Hl`#AcI`f`fBZ+*\$`hc`-Z`\$`k`U]H | | |
| f`8i`fU]cb`cb`ck`Vi`fb | ,`I`%&`\ci`fg | | |
| K]Y][\hk]h`dU]U[]b[| `-\$`V` fI%+*"-`\$`?[`I` | (&\$`V` fI%`\$)`%`?[`I` | `-\$`V` fI%+*"-`\$`?[`I` |
| 9"D'5""9a]gg]cbg | ("(`,`I`fUa`g]AcI`f`fB"%),`cn#AcI`fI` | | |
| Gi`fci`bX`DU]bY`g | | | |
| G]ubXU]fX fk]Xh`I` \Y][\H | | | (*`I`I`&`I` fI%+%`a a`I`+`%`a a`I` |
| Cj`Yfg]hYX fk]Xh`I` \Y][\H | | | (*`I`I`I`I` fI%+%`a a`I`,`(` `a a`I` |
| F]U]b[`@]VY`@cW]h]cb | 6U]`cZI`b]h | | G]XY`cZI`b]h`6Y]\bX` F][\hG]fci`X |

G dYW]Z]WU]c b g

7@95F5B79G'Hc'7CA6I GH+6@9G! '%&\$\$'=-BG9FH

HUVY' . '%&\$\$'=-bgYfh7'YUFUbW'hc'7ca Vi ghjVYg'

| | | |
|---|---|---|
| 5 | A]b]a i a 'WYUFUbW'hc'Ub i bg\jY'XYX'g]XY'k U" | %\$î f&) (' a a Ł |
| 6 | A]b]a i a 'WYUFUbW'hc'Ub i bg\jY'XYX' , î f&,\$' a a Ł'a UbhY' | &?â f) ' ' a a Ł |
| 7 | A]b]a i a 'hcd'ZM]b[' fdfchfi X]b[' î 'Q% 'a a Q' WYUFUbW | %+ î f() ' a a Ł |
| 8 | A]b]a i a 'g]XY'ZM]b[' fdfchfi X]b[' î 'Q% 'a a Q' WYUFUbW | %â f&) ' a a Ł |
| 9 | ™: fca 'Zfcbh'cZ Xccf'cdYb]b['hc'YX[Y'cZ Úccf' dfchV]cb | I G5'%*î f(\$* 'a a Ł 7B8 '% î f() \$' a a Ł |
| : | ™: fca 'g]XY#UW]cZ i b]h hc' YX[Y'cZ Úccf' dfchV]cb | I G5 '*î f?â &' a a Ł 7B8 ' , î f&\$\$ ' a a Ł |

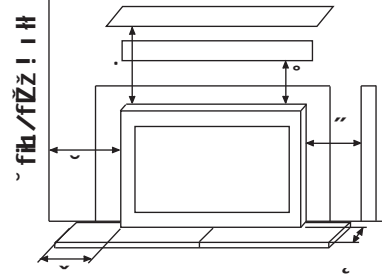

™: @CCF'DFCH97H-CB.'

z i b]h]g'fU]gYX '\$î !' &î f&\$ a a !) % a a Ł / %â f&) a a Ł' bcb! Vta Vi ghjVY' a UHYf]U' k]h _j Ui Y'1 '\$', ('cf'Yei]j UYbh'
z i b]h]g'fU]gYX '\$î !' , î f) % a a ! &\$ ' a a Ł / î f% a a Ł' bcb! Vta Vi ghjVY' a UHYf]U' k]h _j Ui Y'1 '\$', ('cf'Yei]j UYbh'
z i b]h]g'fU]gYX [fYUHYf' h'Ub' , î f&,\$' ' a a Ł' cf' a cfY' / Ubmbcb! Vta Vi ghjVY' a UHYf]U' Wb' VY' i gYX"

HUVY' (. FYXi V]cb]b f&Ł'A]b]a i a '7'YUFUbW'Zca '%&\$\$'hc' , î f&,\$' ' a a Ł'a UbhY'"

| HndY'cZdfchV]cb | A cX]U]YX'7'YUFUbW |
|--|--------------------|
| 5'a]b]a i a 'cZ "\$% î f&\$" ' a a Ł' g\YYh'a YHU' gdUWX'ci h%â f&) a a Ł' Vmbcb! Vta Vi ghjVY'gdUWfg" | %\$ î f&*+' a a Ł |
| 7YfUa]W]h]Ygž' cf' Ye]j UYbh bcb! Vta Vi ghjVY' a UHYf]U' cb' bcb! Vta Vi ghjVY' gj ddcfmg'UbX'gdUWX'ci h%â f&) a a Ł' Vmbcb! Vta Vi ghjVY'gdUWfg" | % (î f) + ' a a Ł |
| 7YfUa]W]h]Ygž' cf' Ye]j UYbh bcb! Vta Vi ghjVY' a UHYf]U' cb' bcb! Vta Vi ghjVY' gj ddcfmg' k]h ' U' a]b]a i a 'cZ "\$% î f&\$" ' a a Ł' g\YYh'a YHU' gdUWX'ci h%â f&) a a Ł' Vm' bcb! Vta Vi ghjVY'gdUWfg" | %\$ î f&*+' a a Ł |

BCH9G

f&Ł'A UbhY' dfchV]cb' a i gh\Uj Y'Uh'YUgh' î f+) a a Ł' YX[Y'WYUFUbW'cb'U" g]XYgž'YI WdhUg'dfcj]XYX']b' BchY' (" f&Ł' zUb'UX'Yg] Y']g' i gYX'hc'gi ddcfmbcb! Vta Vi ghjVY' a UHYf]U'ž']hg'U' bch'cg'Y'UX'Yg] Y'ei U]h]Yg'UhY'a dYfU'hi fYg']_Y'mhc' VY'YbVti bhYfYX'UbX'g'U' bchVtbf]Vi H'U'g] [b]UWbVta Vi ghjVY'c'UX"
fî Ł' <YUhg\jYX' a ci bh]b[\UfXk UfY'UHUWYX'hc' Vta Vi ghjVY' a UHYf]U'g' a i ghVY'd'UWX'UhH'Y'UHYFU'YI HfYa]h]Yg'cZ h'Y'g\jYX"

f(Ł'A]b]a i a 'WYUFUbW'hc' i bdfchV]WX'k U'g'UbX'W]]b[g' a i ghVY' a U]bh]bYX"

HUVY) . '%&\$\$'=-bgYfhA]b]a i a :]fYd'UW'G]nY"

| | A Ugcbfm | NYfc'7'YUFUbW |
|---|--|----------------------|
| A]b]a i a '8Ydh | % î f(' ' a a Ł | % (î f&+ - ' a a Ł |
| A]b]a i a 'K]XH' Uh'VUW]cZ ÚfYd'UW | && î f) * , ' a a Ł | & î f) , (' a a Ł |
| A]b]a i a 'K]XH' Uh'ZfcbhcZ ÚfYd'UW | &+ î f* , * ' a a Ł | &+ î f* - & ' a a Ł |
| A]b]a i a 'K]XH' Uh'ZfcbhcZ ÚfYd'UW'hc']bW'XY'g\fc i X | ' ' î f) + ' a a Ł | ' (î f) * (' a a Ł |
| A]b]a i a '<Y][\h | % î f(, - ' a a Ł + cf% î f) \$&' a a Ł | &\$î f) \$, ' a a Ł |

†† z h'Y' a Ugcbfm]bhY' \Y][\h]g'cb'm% î f(, - ' a a Ł'hc' % î f) \$&' a a Ł' fYZf'hc' =BGH5@5H-CB' ! 'A C8= =75H-CBG' : CF' =BGH5@5H-CB' k +k % î f(, - ' AAŁ' < = < @BH9@! =BG9FH

G dYW]Z]WU]c b g

7@95F5B79G'Hc'7CA6I GH6@9G! '%+\$\$'=-BG9FH

HUV'Y* . '%+\$\$'=-bgYfh7'YUFUbW'hc'7ca Vi gh]VYg'

| | | |
|---|--|---|
| 5 | A]b]a i a 'WUfUbW'hc'Ub'i bg\]Y'XYX'g]XY'k U` | %\$! f&) ('a a t |
| 6 | A]b]a i a 'WUfUbW'hc'Ub'i bg\]Y'XYX', !'f&\$' ' a a t'a UbH' | &(! f*%\$' a a t |
| 7 | A]b]a i a 'hcd'ZUM]b['ftfchfi X]b[' !'.....% ' a a Q'WUfUbW | % ! f(-) 'a a t |
| 8 | A]b]a i a 'g]XY'ZUM]b['ftfchfi X]b[' !'.....% ' a a Q'WUfUbW | %! f&) 'a a t |
| 9 | TM: fca 'ZfcbhcZxcfc'dYb]b['hc'YX[Y'cZ'Uccf' dfchV]cb | I G5'% ! f(\$* 'a a t 7B8 '% ! f() \$' a a t |
| : | TM: fca 'g]XY#VUW' cZ i b]h'hc' YX[Y'cZ'Uccf' dfchV]cb | I G5* ! f!& 'a a t 7B8, ! f&\$ \$' a a t |

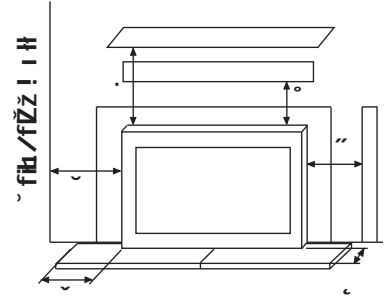

TM: @CCF'DFCH97H-CB.'

=Zi b]h]g'fU]gYX '\$! !' & f&\$' a a !)'% a a t/'% f&) a a t' bcb! Vta Vi gh]VY' a UHYf]U' k]h' _j Ui Y'1 '\$', ('cf'Yei]j UYbh'
 =Zi b]h]g'fU]gYX '\$! !', !' f) % a a !&\$' a a t/' !' f% a a t' bcb! Vta Vi gh]VY' a UHYf]U' k]h' _j Ui Y'1 '\$', ('cf'Yei]j UYbh'
 =Zi b]h]g'fU]gYX [fYUhf'hUb', !' f&\$' ' a a t'cf' a cfY/Ubmbcb! Vta Vi gh]VY' a UHYf]U' Wb' VY' i gYX"

HUV'Y+. FYXi V]cb]b f&E'A]b]a i a '7'YUFUbW'Zca '%+\$\$'hc', !'f&\$' ' a a t'a UbH'

| HndY'cZdfchV]cb | AcX]U]YX'7'YUFUbW |
|---|---------------------|
| 5'a]b]a i a 'cZ '\$% !' f&\$' ' a a t'g\YYh'a YHU'gdUWX'ci h% f&) a a t'Vmmbcb! Vta Vi gh]VY'gdUWfg' | %& ! f) \$' ' a a t |
| 7YfUa]W]h]Yg'z' cf' Ye]j UYbh bcb! Vta Vi gh]VY' a UHYf]U' cb' bcb! Vta Vi gh]VY' g] ddcf]g'UbX'gdUWX'ci h% f&) a a t'Vmmbcb! Vta Vi gh]VY'gdUWfg' | % ! f(\$, ' a a t |
| 7YfUa]W]h]Yg'z' cf' Ye]j UYbh bcb! Vta Vi gh]VY' a UHYf]U' cb' bcb! Vta Vi gh]VY' g] ddcf]g'k]h' U' a]b]a i a 'cZ '\$% !' f&\$' ' a a t'g\YYh'a YHU'gdUWX'ci h% f&) a a t'Vmmbcb! Vta Vi gh]VY'gdUWfg' | %& ! f) \$' ' a a t |

BCH9G

f&E'A UbH' dfchV]cb' a i gh\Uj Y'Uh'YUgh' !' f+) a a t'YX[Y'WUfUbW'cb'U' g]XYg'YI WdhUg'dfcj]XYX']b' BchY' (" f&E' =ZUb'UX\Yg]]Y'g] i gYX'hc'g] ddcf]h' bcb! Vta Vi gh]VY' a UHYf]U'z']hg'U' bch'cg'Y'UX\Yg]]Y'ei U]h]Yg'Uh]Y'a dYfU]h' fYg']_Y'm]tc' VY'YbVti b]h]fYX'UbX'g'U' bchVtbf]Vi H'U'g] [b]U]Wb]h'Vta Vi gh]VY'c'UX"

f] E' < YUhg\]YX' a ci bh]b[\UfXk UfY'U]UWYX'hc' Vta Vi gh]VY' a UHYf]U'g' a i gh]VY' d'UWX'Uh]h'Y'UHYfU'YI HfYa]h]Yg'cZ h\Y'g\]YX"

f(E'A]b]a i a 'WUfUbW'hc' i bdfchV]WX'k U'g'UbX'W]]b[g'a i gh]VY' a U]bh]U]bYX"

HUV'Y, . '%+\$\$'=-bgYfhA]b]a i a :]fYd'UW'G]nY"

| | A Ugcbfm | NYfc'7'YUFUbW |
|--|--------------------------------------|---------------------|
| A]b]a i a '8Ydh | % ! f(+) 'a a t | % ! f(+ \$' a a t |
| A]b]a i a 'K]Xh' Uh'VUW'cZ'UfYd'UW | && ! f) *, 'a a t | & ! f), ('a a t |
| A]b]a i a 'K]Xh' Uh'ZfcbhcZ'UfYd'UW | &+ ! f*, * 'a a t | &+ ! f* - & 'a a t |
| A]b]a i a 'K]Xh' Uh'ZfcbhcZ'UfYd'UW'hc']b]W'XY'g\fc] X | ' ' ! f) + 'a a t | ' (! f) * ('a a t |
| A]b]a i a '<Y][\h | % ! f(- 'a a t + cf% ! f) \$&' a a t | %& ! f) \$, ' a a t |

f] f' =Zh]Y' a Ugcbfm]bhY' \Y][\h]g'cb'm% !' f(- ' a a t'hc' % !' f) \$&' a a t'fYZf'hc' =BGH5@5H-CB' !' A C8 = =75H-CBG' : CF' =BGH5@5H-CB' k +k % !' f(- ' AA E' < = < @BH9@! =BG9FH

G dYW]Z]WU]h]c b g

7@95F5B79G'Hc'7CA6l GH+6@9G! '%&\$\$': F99GH5B8-B; .

A5-BH5-B'H<9G9'A-B=A| A'7@95F5B79G'HC' BG<=9@898'7CA6l GH+6@9G'

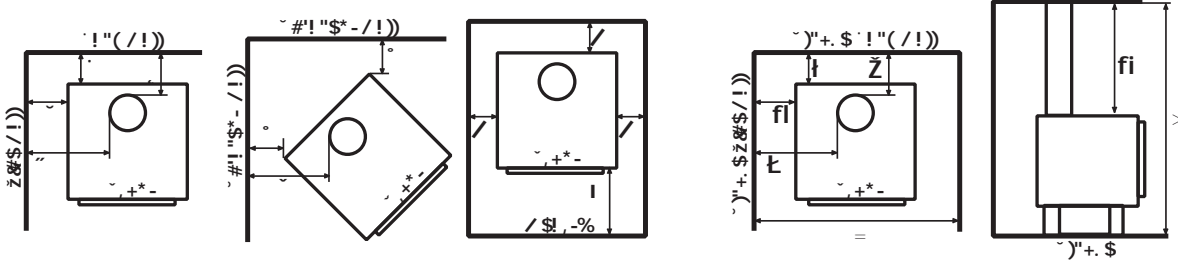

HUV'Y' - '%&\$\$': fYg]UbX]b['7YUfUbW'hc'7ca Vi gh]VYg'

| | G]b['Y'K U''D]dY | 8ci VY'K U''D]dY f | 8ci VY'K U''D]dY' k]h' <YUh9ZU]WbVh G\Y'X') \$!%, , 'fl' U'h hcd'a cXY'cb'mt | Hd'j Ybhci hVUW' k U''k]h' 'a]b'' &('ft' %\$'a a t]j Yfh]W' f]gY/ Xci VY'k U'' | |
|---------------------------------|---|---|---|---|---|
| 5 | : fca 'g]XY'k U'' hc'g]XY'cZi b]h | % I fl' \$'a a t | % I fl' \$'a a t | % I fl' \$'a a t | %(I fl) * 'a a t |
| 6 | : fca 'fYUf'k U'' hc'VUW'cZi b]h | %& fB+- 'a a t | %\$ I fB) ('a a t | , I fB\$' 'a a t | %& fl \$) 'a a t |
| 7 | : fca 'UX'UWbhk U'' hc'Wfbyf'cZi b]h | - I fB&- 'a a t | , I fB\$' 'a a t | * I fB%) 'a a t | |
| 8 | : fca 'g]XY'k U'' hc'Wf'Uf | && f)) - 'a a t | && f)) - 'a a t | && f)) - 'a a t | & I f) , ('a a t |
| 9 | : fca 'fYUf'k U'' hc'Wf'Uf | %(I fl) * 'a a t | % I fl' \$'a a t | %& fB+- 'a a t | % I fl , % a a t |
| : | : fca 'UX'UWbhk U'' hc'Wf'Uf | %+ I f() 'a a t | %* I f(% 'a a t | % I fl * , 'a a t | |
| ; | TM: fca 'Xccf'cdYb]b[hc'YX[Y'cZ\YUf]h' dUX | I G5' % I f(\$* 'a a t 7B8' % I f() \$'a a t | I G5' % I f(\$* 'a a t 7B8' % I f() \$'a a t | I G5' % I f(\$* 'a a t 7B8' % I f() \$'a a t | I G5' % I f(\$* 'a a t 7B8' % I f() \$'a a t |
| < | TM: fca 'g]XY#UW'cZi b]h hc'YX[Y'cZ\YUf]h' dUX | I G5' * I fB) & 'a a t 7B8' , I fB\$ \$'a a t | I G5' * I fB) & 'a a t 7B8' , I fB\$ \$'a a t | I G5' * I fB) & 'a a t 7B8' , I fB\$ \$'a a t | I G5' * I fB) & 'a a t 7B8' , I fB\$ \$'a a t |
| 5W] Y'f(, I' %&\$\$' a a Q8YdL | | | | | |
| = | Hc]U'K]Xh | |) I fB% - 'a a t | | |
| > | Hc]U' <Y] [\h | | + , I fB% , % a a t | | |
| ? | Hcd'cZg]c] Y'hc'W]]b[| | (- I fB) () 'a a t | | |
| @ | G]XY'k U''hc'g]c] Y | | % I fl , % a a t | | |
| A | G]XY'k U''hc'd]dY | | &(I ft' % \$' a a t | | |
| B | 6UW'k U''hc'i b]h | | %& fl \$) 'a a t | | |
| C | 6UW'k U''hc'd]dY | | % I fl , % a a t | | |

75l H-CB. '5b'i b]bg] 'UHX'ga c_Y'd]dY'a i gh'bchi dUgg'h'fci [\ 'Ub' UH]W'fccZ gdUWz'WcgYh'cf'g]a]Uf'WbWUYY'gdUWz'cf'h'fci [\ 'U'Uccfz'W]]b['z'k U'z'cf'dUfh]]cbz'cf'Ubm]W'a Vi gh]VY'Wb]g]fi V]cb"

TM: @CCF DFCH97H-CB. 'Z'U'g]c] Y']g]]bg]U'YX'cb'U'W'a Vi gh]VY'U'ccfz']h'a i gh'U] Y'U'dYXYg]U'cf'Y []]h'k]h' U'g] dUb'UH]UWYX'UbX'VY'cb'U'BCB!7CA6l GH+6@9\YUf]h' dUX'

f'5@7@95F5B79G'75B'69'F98l 798'K +k'G<=9@8-B; '5779DH56@9'HC'H<9'@75@5l H<CF#HVI
f'8Cl 6@9'K 5@'

B'75B585.'5bml @!G* &- ']ghY'W]a bYm]g]h'Y'a 'k]h' h'Y'UW]a dUb]b[']ghY'Xci VY'k U''j Ybh]Wb]bbY]W'c'f'
B'l "G'5". 5bml @%\$' <H']ghY'W]a bYm]g]h'Y'a 'k]h' h'Y'UW]a dUb]b[']ghY'Xci VY'k U''j Ybh]Wb]bbY]W'c'f'

G dYW]Z]WU]h]c b g

7@95F5B79G'Hc'7CA6l GH+6@9G! '%t\$:\$': F99GH5B8=B; .

A5=BH5=B'H<9G9'A =B=A I A'7@95F5B79G'Hc' i BG<=9@898'7CA6l GH+6@9G'

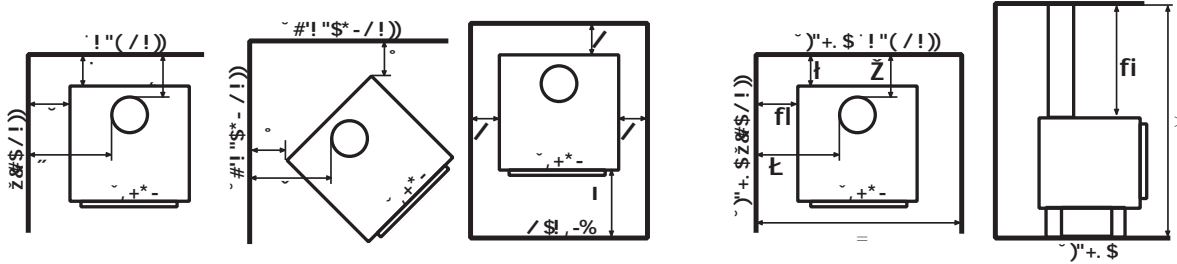

HUVY%\$. %+\$:\$: fYYgUbx]b['7YUfUbw'hc'7ca Vi gh]VYg'

| | G]b['Y'K U''D]dY | 8ci VY'K U''D]dY f | 8ci VY'K U''D]dY' k]h' <YUh9ZUM]WbVh G\Y'X') \$!%\$, , 'fl' U'h hcd'a cXY'cb'mt | Hcd'j Ybhci hVUW' k U''k]h' 'a]b'' &('f' %\$'a a t j Yfh]W' f]gY/Xci VY'k U'' | |
|---|--|--------------------------------------|--|--|--------------------------------------|
| 5 | : fca 'g]XY'k U'' hc'g]XY'cZi b]h | &\$f f) \$, 'a a t | % f fl' \$'a a t | % f fl' \$'a a t | % f fB+- 'a a t |
| 6 | : fca 'fYUf'k U'' hc'VUW'cZi b]h | % f fl \$) 'a a t | % f fB) ('a a t | + f fB+, 'a a t | % f fl' \$'a a t |
| 7 | : fca 'UX'UWbhk U'' hc'VdfbYf'cZi b]h | % f fB) ('a a t | , f fB%'a a t | * f fB) &'a a t | |
| 8 | : fca 'g]XY'k U'' hc'Vd'Uf | &- f fh' + 'a a t | &f f) - 'a a t | &f f) - 'a a t | &\$f f) \$, 'a a t |
| 9 | : fca 'fYUf'k U'' hc'Vd'Uf | % f fl , %a a t | % f fl' \$'a a t | % f fB) ('a a t | % f f(\$'a a t |
| : | : fca 'UX'UWbhk U'' hc'Vd'Uf | % f f(+ \$'a a t | % f f(' &'a a t | % f fl *, 'a a t | |
| ; | TM: fca 'Xccf'cdYb]b[hc'YX[Y'cZ\YUfh' dUX | I G5%'f(\$'a a t 7B8%'f(\$'a a t | I G5%'f(\$'a a t 7B8%'f(\$'a a t | I G5%'f(\$'a a t 7B8%'f(\$'a a t | I G5%'f(\$'a a t 7B8%'f(\$'a a t |
| < | TM: fca 'g]XY#UW'cZi b]h hc'YX[Y'cZ\YUfh' dUX | I G5*'f) &'a a t 7B8', f) &'a a t | I G5*'f) &'a a t 7B8', f) &'a a t | I G5*'f) &'a a t 7B8', f) &'a a t | I G5*'f) &'a a t 7B8', f) &'a a t |
| = | 5Vd] Y'f(, f'8YYdE' | | | | |
| > | Hc]U'K]Xh | |) f) f) &- 'a a t | | |
| ? | Hc]U'<Y][\h | | + &f) f) &- 'a a t | | |
| @ | Hcd'cZg]c] Y'hc'W]]b[| | ((f) f) % 'a a t | | |
| A | G]XY'k U''hc'g]c] Y | | % f fl' \$'a a t | | |
| B | G]XY'k U''hc'd]dY | | &f) f) - 'a a t | | |
| B | 6UW'k U''hc'i b]h | | , f) f) \$'a a t | | |
| C | 6UW'k U''hc'd]dY | | % f) f) + 'a a t | | |

75I H=CB. '5bi i b]bg] 'UHX'ga c_Y'd]dY'a i gh'bchi dUgg'h'fci [\ 'Ub' UH]W'fccZ gdUW'z WcgYh'cf'g]a]Uf' VdbWUYY' gdUW'z'cf'h'fci [\ 'U'Uccf'z'W]]b['z'k U'z'cf'dUfh]]cbz'cf'UbmVda Vi gh]VY'Vdbgf] V]cb"

TM: @CCF DFCH97H=CB. 'ZU'g]c] Y'g]bg]U'YX'cb'U'Vda Vi gh]VY'Uccf'z]ha i gh]Uj Y'U'dYXYg]U'cf'Y[]h]k]h' Ugv' dUb' UH]UW'YX'UbX'VY'cb'U'BCB!7CA6l GH+6@9\YUfh' dUX'

f'5@7@95F5B79G'75B'69'F98l 798'K +k'G<=9@8-B; '5779DH56@9'HC'H<9'@75@5l H<CF+HVI

f'8Cl 6@9'K 5@@'

=B'75B585.'5bml @!G* &- 'gh]X'W]a bYmgngh]a 'k]h' h'Y'UW]da dUb]b['gh]X'Xci VY'k U''j YbhVdbbYV]cf"

=B'l"G'5'.5bml @%\$' <H'gh]X'W]a bYmgngh]a 'k]h' h'Y'UW]da dUb]b['gh]X'Xci VY'k U''j YbhVdbbYV]cf"

G dYW]Z]WU]h]c b g

8-A 9BG-CBG! %&\$\$ =BG9FH.

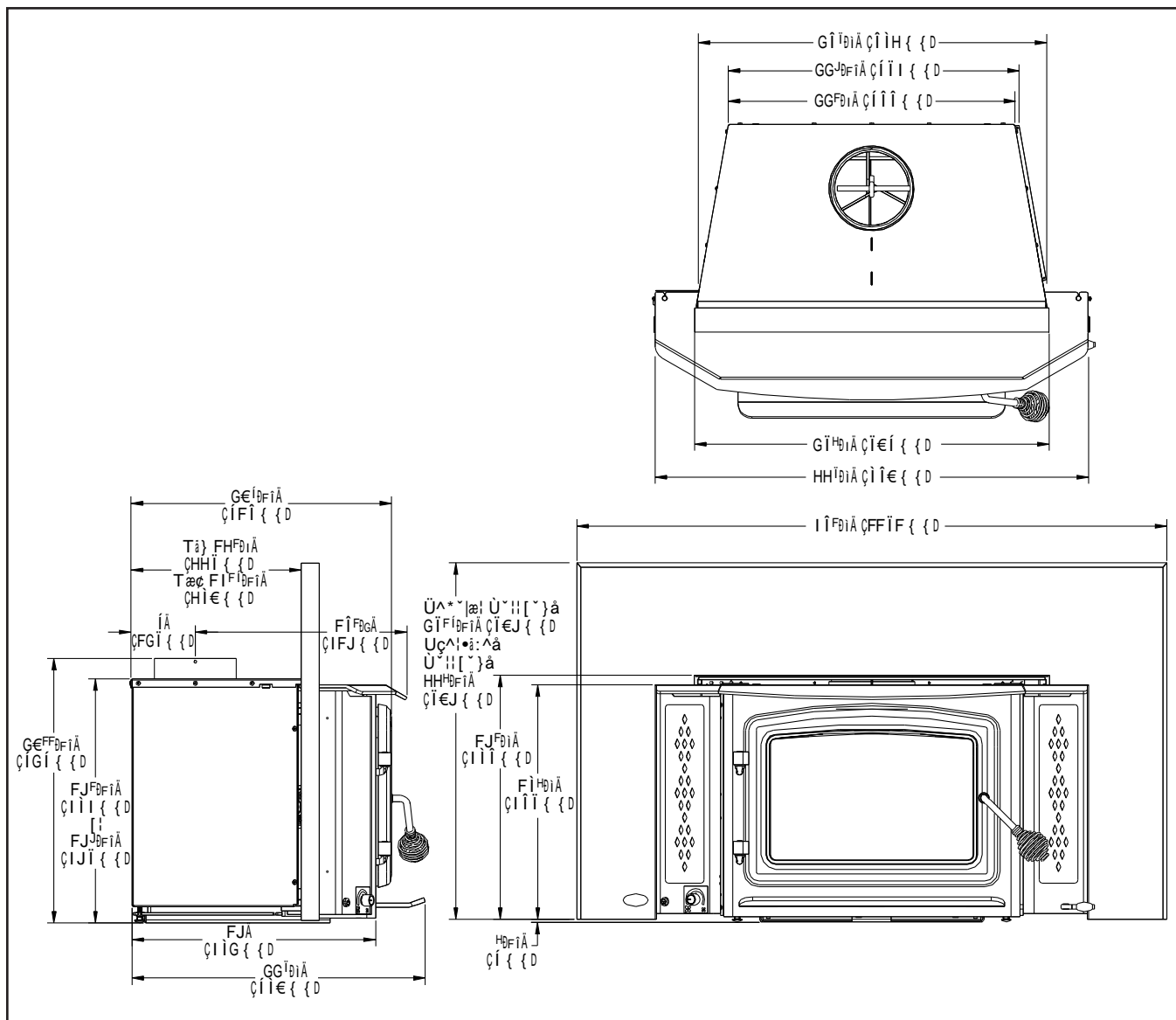

:] [i fY*. %&\$\$ =bgYfh'8]a Ybg]cbg'

G dYW]Z]WU]c b g

8-A 9BG-CBG! %&\$\$ =BG9FH.

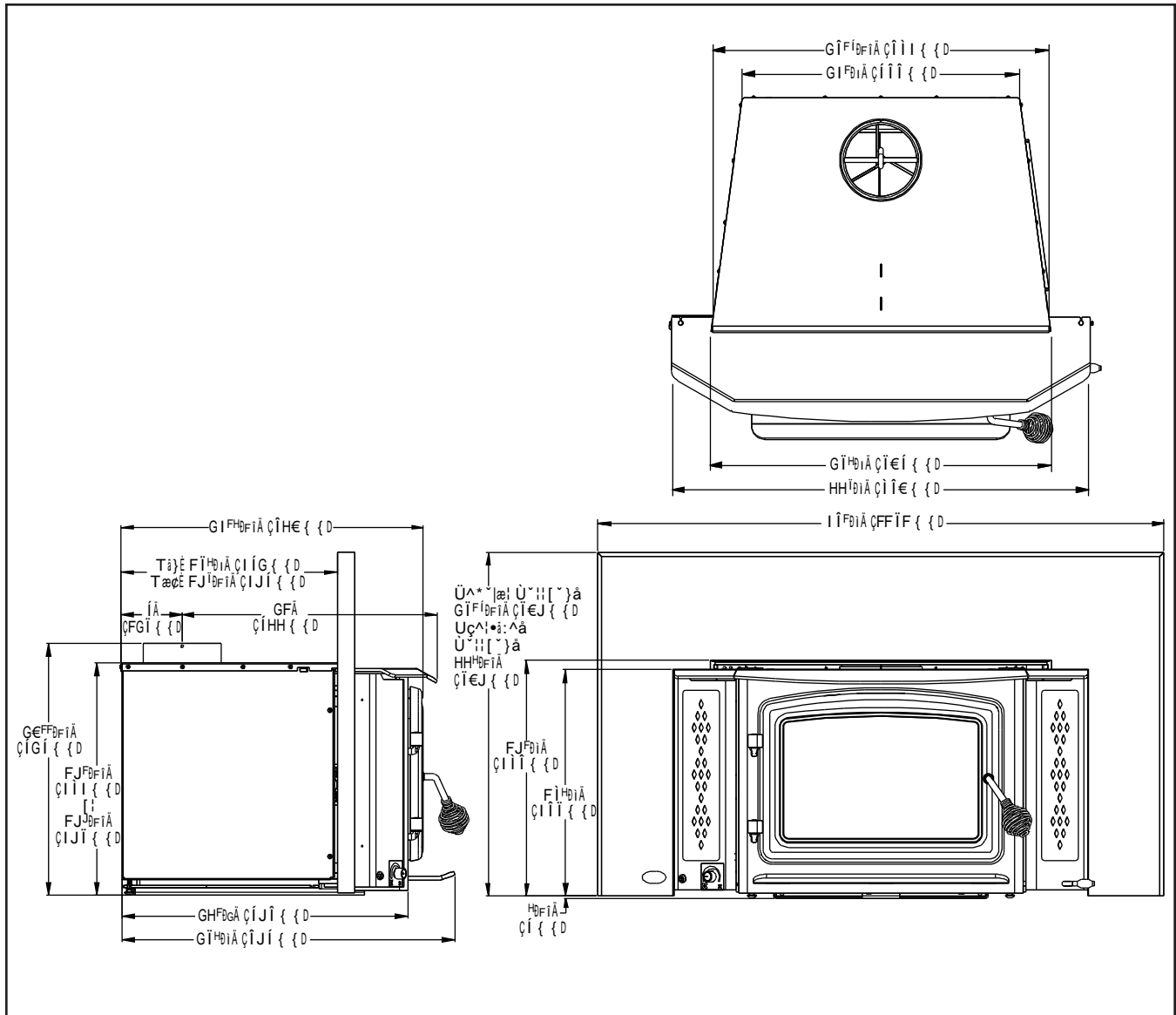

:] [i fY+. %&\$\$ =bgYfh]a Ybg]cbg'

G dYW]Z]WU]h]c b g

8-A 9BG-CBG! %+\$\$: F 99GH5B8-B; .

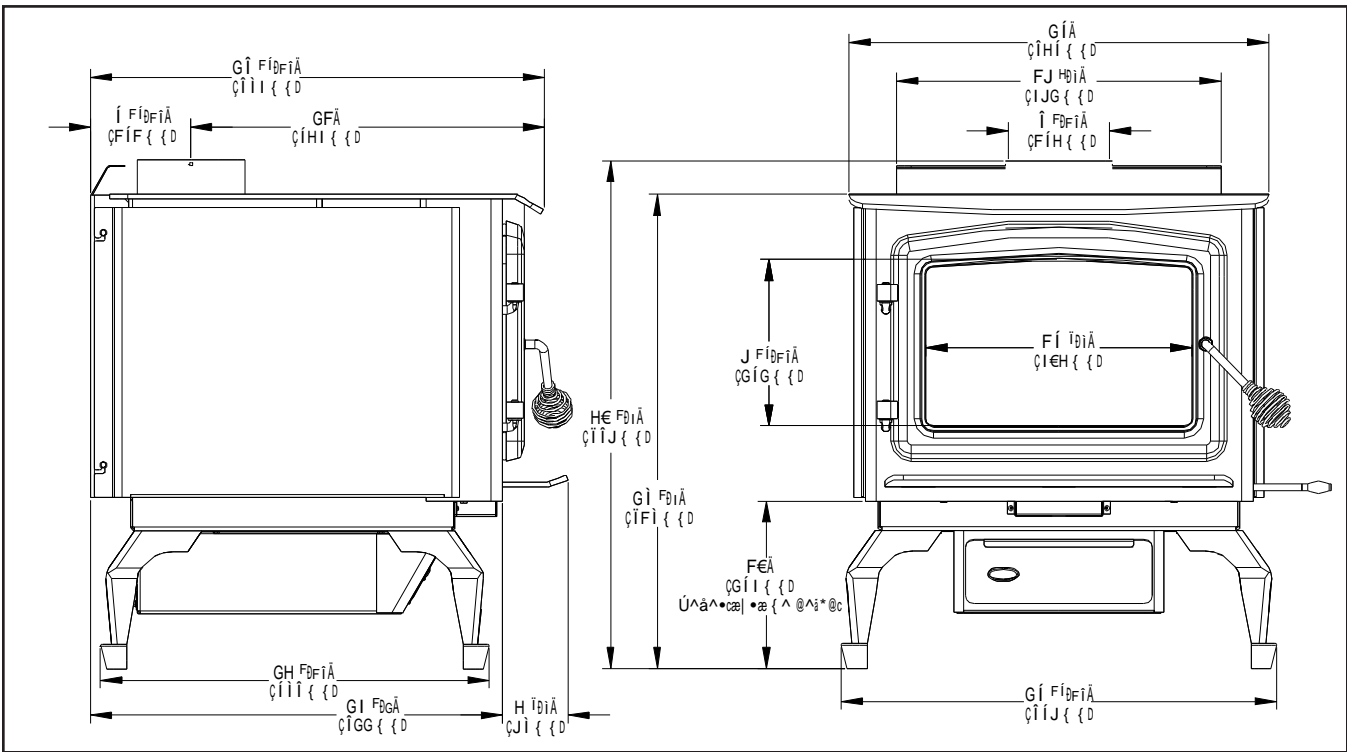

:] [i fY %\$. %+\$\$: fYyG]UbX]b [: `UhHcd`8]a Ybg]cbg'

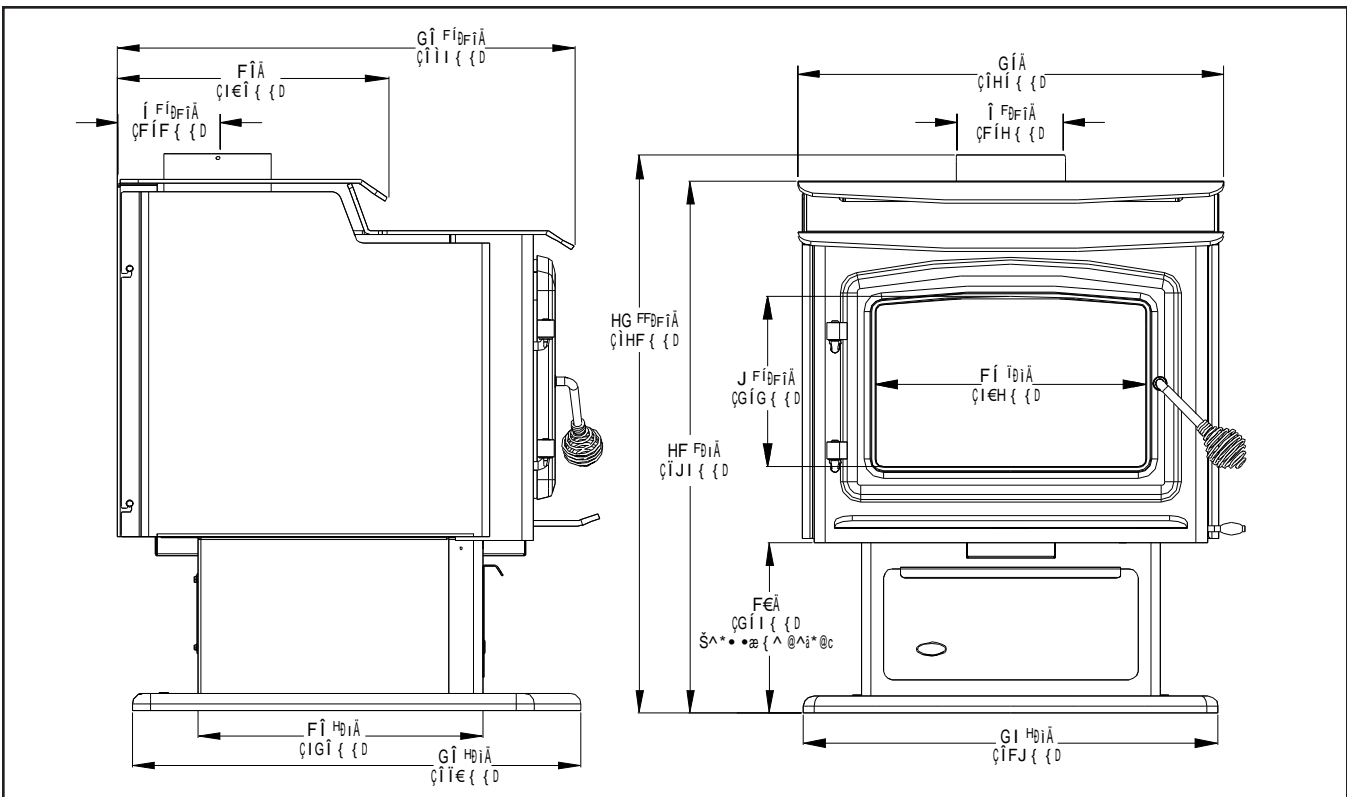

:] [i fY %%% %+\$\$: fYyG]UbX]b [`GhYd`Hcd`8]a Ybg]cbg'

G dYW]Z]WUh]c b g

: F99GH5B8-B; 'G-89'8-A9BG-CBG': CF : 5B ?=H

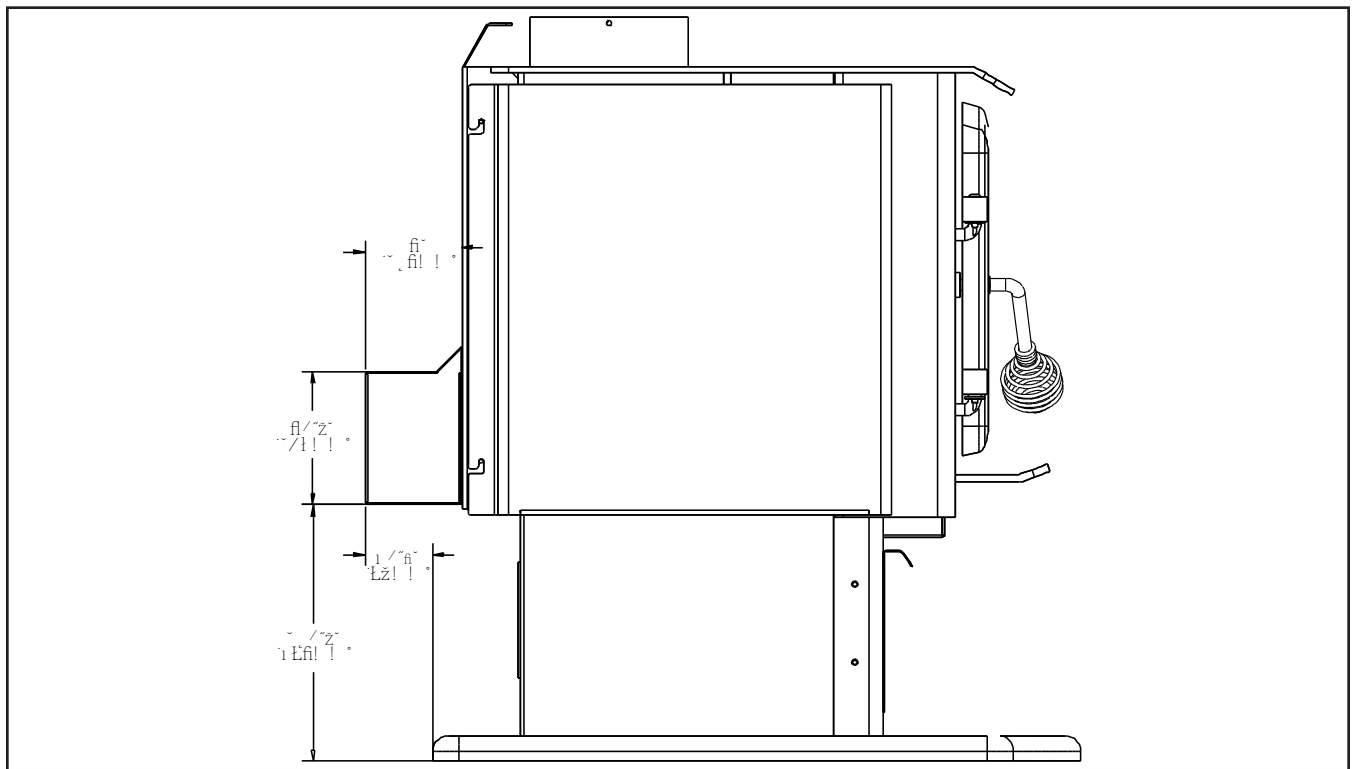

: [i fY%&.%&\$\$: fYYgHbX]b[k]H : Ub ?]h8]a Ybg]cbg'

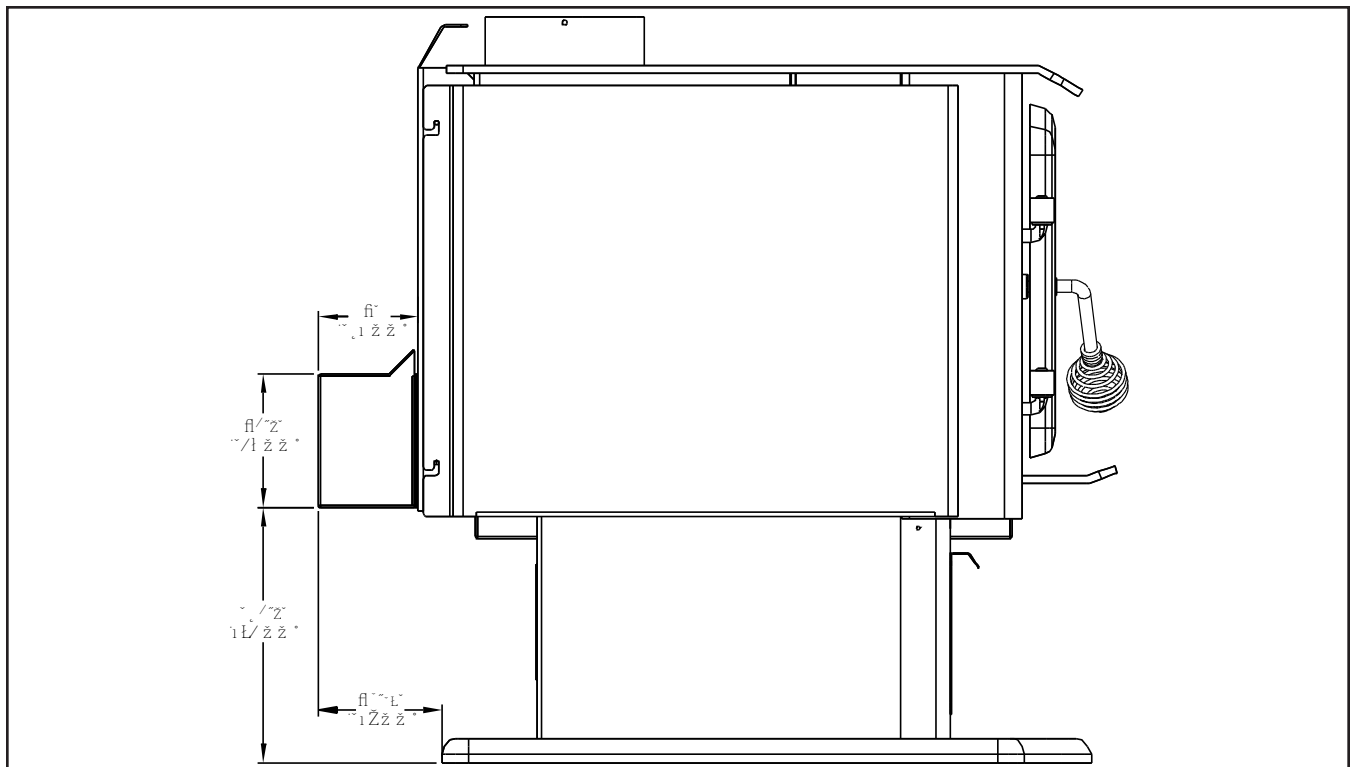

: [i fY% . %&\$\$: fYYgHbX]b[k]H : Ub ?]h8]a Ybg]cbg'

=bghU` `Uh]c b

D'YUgY' fYUX' UbX' i bXYfgtUbX' hYgY']bgrfi W]cbg' VYZcfY']bgtU`]b[' dYXYgtU' cf' Ug\` dUb' UbX' `Y[' cdh]cb'' : U]i fY' hc' Zc' `ck' hYgY']bgrfi W]cbg' WfYZ' `mVzi' `X' Wli' gy' dYfgcbU']b[fmicf' dfcdYfmXUa U[Y'' 5'' gWYk' g' UfY' dfY!]bgtU` YX' cb' hY' VUgY' cZ' hY' i b]h'

F 9ACJ 5@: FCA 'D5@9H.

i' FYa' cj' Y' hY' Vf]W]g' Zfca' `hY' i b]h' VYZcfY' gUfh]b[''
 i' FYa' cj' Y' hY' `k' c' f&E' Wff]U[Y' Vc' hg' fb\ck' b']b' :]i fY' %' E' `h' UhgY' WfY' hY' i b]h' hc' hY' dU' Yh' Zfca']bg]XY' hY' U' fY' Vcl' ''

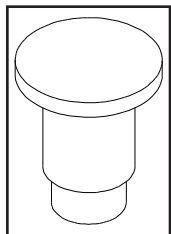

:]i fY' %' .
 F]j YH'

BchY. `5ZYf' hY' dYXYgtU' cf' `Y[g' UbX' Ug\` dUb' `Uj' Y' VYYb']bgtU` YX' Vi' h' VYZcfY' hY' Vf]W]g' UfY']bgtU` YX' Z' f]j' Yhg' fi']i fY' %' (E' a' gh' VY' d' UWX']b' hY' `k' c' f&E' `c' Yg' fb\ck' b']b' :]i fY' %' E']b' hY' U' fY' Vcl' `h' Uh' Wff]U[Y' Vc' hg' Wla' Y' ci' hc' Z' h' h']g']g' XcbY' hc' `a' U_ Y' i b]h' Vi' fb' `a' cfY' YZ' W]b' h' h' hY' g' ci' `XY' f]j' Yhg' UfY' Zci' bX']b' hY' `a' Ubi' U' VU[''

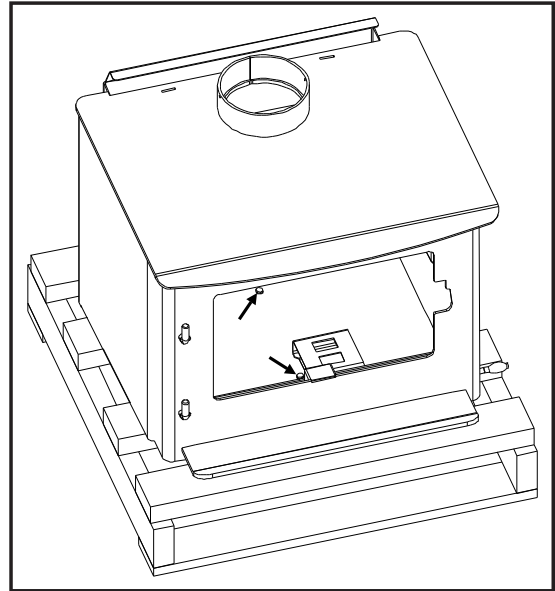

:]i fY' %' . `6c' hg' hc' fYa' cj' Y''

D989G+5@ =BG+5@5H+CB' ! : F 99G+5B8-B; .

€' D'UW' hY' i b]h' cb' hY' dU' Yh' icb']hg' VUW''
 i' G]XY' hY' dYXYgtU' UggYa' V' m' cj' Yf' hY' Vc' hg' `c' W]hYX' cb' hY' VUgY' cZ' hY' i b]h' i' g]b[' hY' _Yn' h' `c' YX' g' chg' dfcj']XYX''
 i' H]] `h' Yb' U' `Zci' f' f(E' Vc' hg' Ybgi' f]b[' hY' dYXYgtU']g' dfcdYf' mU']i' bYX' hc' hY' YX[Yg' cZ' hY' i b]h' i'
 i' G]h' bX' hY' i b]h' cb' hY' dYXYgtU' UbX' gYh' hY' i b]h']b' hY' `c' W]h]cb' fYUX' m' Z' cf']bgtU' U' h]cb''
 i' `Z' ZYg\` U]f' gi' dd' m']g' VY']b[' gi' dd']YX' Zfca' `hY' Vc' h' ca' `cZ' hY' i b]h' d' YUgY']bgtU` `hY' Vdz' Yf' d' U' h' gi' dd']YX' hc' hY' fYUf' cZ' hY' dYXYgtU' Vdz' Yf]b[' hY' (']b' W' f' P' S' V' d' E' `c' Y''

BchY. ` `b' gY]ga']W' m' U' W]j' Y' UfYUgZ']h']g' fYVca' a' YbXYX' `h' Uh' n' ci' f' i b]h']g' gY' W' fYX' hc' hY' U' ccf' V' mi' g]b[' hY' Vc' h' X' ck' b' `c' Yg']bg]XY' hY' dYXYgtU''

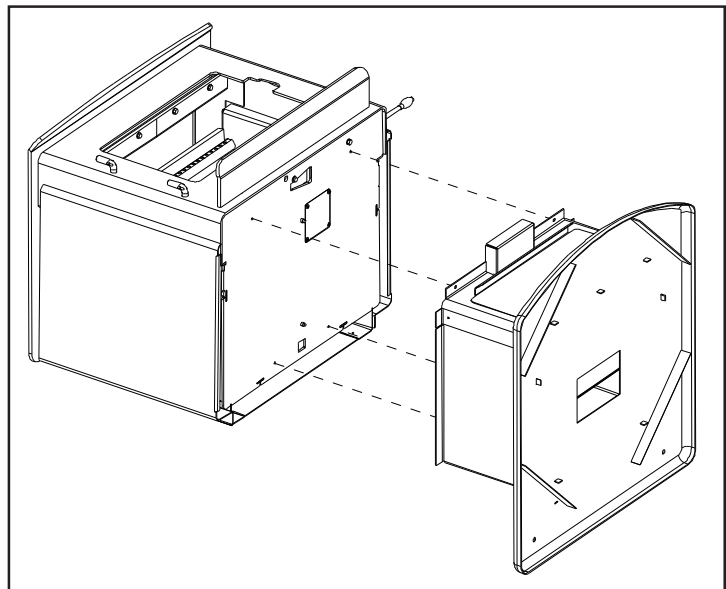

:]i fY' %' . `=bgtU`]b[' dYXYgtU''

=bghU` `Uh]c b

@, G'5B8'5G< D5B '=BGH5@5H-CB ! : F99GH5B8-B; .

##D'UW` hAY i b]h'cb` hAY` dU`Yh'cb`]hg`
VUW`

i` 5H'UW` dYXYghU` gdUWf` hc` Vcl'ca`
cZ` hAY` i b]h'z` i g]b[` hAY` gi` dd`]YX`
gWYk` g'

i` 5H'UW` hAY` U]f` W'UbbY` Vcl` hc` hAY`
Z'cbh'cZ` hAY` dYXYghU` gdUWf` i g]b[` hAY`
k` c` f&L` H` \$&` gWYk` g'

##G`JY` hAY` Ug` dUb` UggYa` V'mcj` Yf`
hAY` Vc`hgz` i g]b[` hAY` _Ym\c`YX`
g'chg'dfcj`]YXz` UbX` h[\` hYb` U` Zci` f`
f(` E` Vc`hg`

##7UFYZ` m` fYa` cj` Y` hAY` Wgh`]fcb`
Y[g` Z'ca` hAY` dUWU[]b[` UbX`
gYW` fY` YUW` Y[` k`]h` k` c` f&L` Vc`hg`
dfcj`]YX`

##GYW` fY` U` Zci` f` f(` E` Y[g'z` di` g` hAY`
Y[` h'ck` UfXg` hAY` WbhYf` cZ` hAY` g'rcj` Y` UbX` U[]b` hAY` Y[g` k`]h` hAY` ci` hYf` YX[Yg` cZ` hAY` UfYVcl` "

##GHUbX` hAY` i b]h'cb` hAY` Y[g` UbX` gYh` hAY` i b]h]b` hAY` c` Vh]cb` fYUXmZcf`]bghU` Uh]cb`

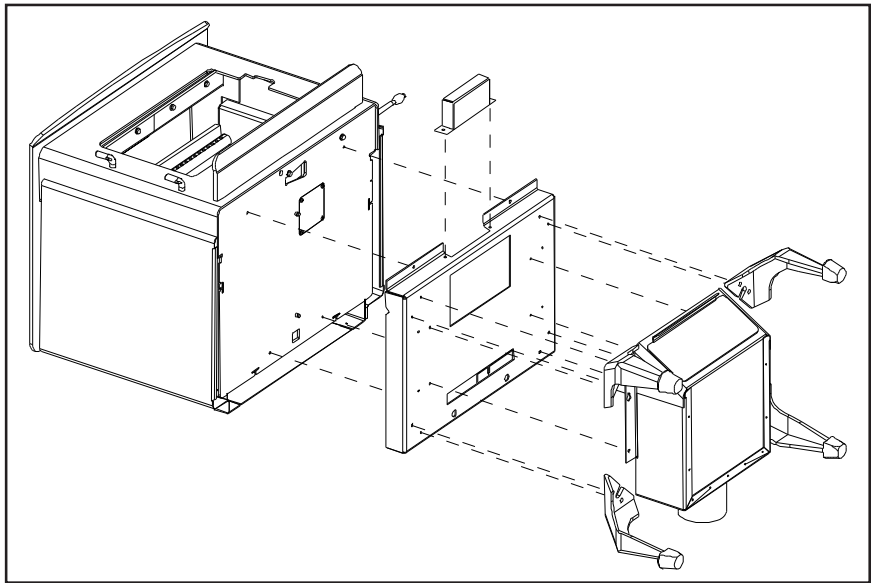

:]i` i` fY`%+. `=bghU`]b[` @Y[g`UbX`5g` DUb`5ggYa` V`m'f

=BGH5@5H-CB` C: < 95H! 9: =7=9B7MG< =9@B ! : F99GH5B8-B; : @5H`Hcd.

HAY` \YUHYZM`YbW`h` g\]YX`]g`]bghU`YX` hc` `ck` Yf` hAY`
WYUf`UbW`g`hc` Vt'a` Vi` gh]V`Yg`cb` hAY` UUh'cd` Z'fY`gh`UbX`]b[` a` cXY`"

%` hAY` i b]h'a` i gh`VY`]b` d'cg]h]cb` Zcf` hAY`]bghU` Uh]cb` UbX`
k`]h` hAY` j` Ybh]b[` fYUXmhc` VY` UggYa` V`YX`"

&` @ccgYb` hAY` k` c` f&L` h'cd` gWYk` g`cb` hAY` VUW` cZ` hAY`
i b]h'i` g]b[` U`)`#` i` gcW`YH`

'` "D'UW` hAY` \YUHYZM`YbW`h`g\]YX` cb` h'cd` cZi` b]h`

("G`JY` W`ja` bYm` Vt'bbYVt'cf` h'fci` [\ ` hAY` \YUH
YZM`YbW`h`g\]YX` UbX` cj` Yf` hAY` U`i` Y`"

)` "q`z` hAY` \YUHYZM`YbW`h` g\]YX` UbX` gWYk` hAY`
W`ja` bYm`Vt'bbYVt'cf` hc` hAY` U`i` Y`"

*` "G`JY` hAY` \YUHYZM`YbW`h`g\]YX` Xck` b` UbX` \cc_` hAY`
g`chi`Uh`hAY` VUW` cZ` hAY` g\]YX` z` Ufci` bX` hAY` c'ccgYbYX`
gWYk` g`Uh`hAY` VUW` cZ` hAY` i b]h`

+` "H[\` hYb` hAY` k` c` f&L` gWYk` g`Uh`hAY` VUW`"

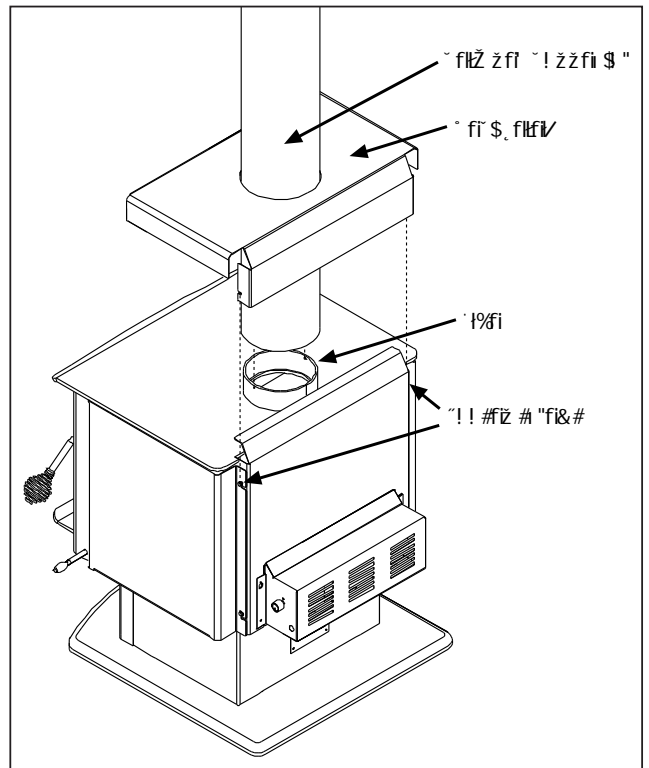

:]i` i` fY`% . `=bghU`]b[< YUH`G\]YX`"

=bghU` `Uh]c b

A C8= =75H-CBG: CF =BGH5@5H-CB K Hk % Î f(, -AAE' <=, < @BH9@! =BG9FH

HAY?cX]U_ \Ug U' ZUMcfm\Y][\hicz % -#%Î f(- +a a E' UbX']h Wb' VY fYXi WX' hc' % %#%Î f(, (a a E' Vm a cX]h]b['hAY' i b]hUbX'hAY' gi ffc i bX'dUbY"

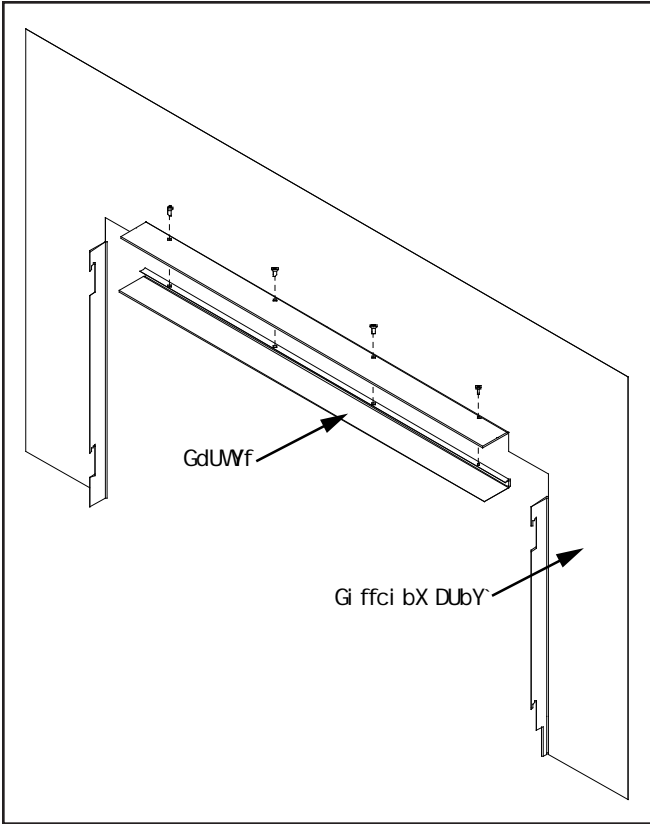

Gi ffc i bX'DUbY.

%": UghYb' hAY' Gi ffc i bX' GdUWf' hc' hAY']bbYf' hcd' gi fZUW' cZHAY' Gi ffc i bX' DUbY' i g]b['hAY' Zci f' f(E' H & \$ gWYk g' ffYZf' hc':][i fY' % E"

&": FYZf' hc' =BGH5@5H-CB C: 'Hk'9' Gi ffc i bX' D5B9@! =BG9FH' hc' Ub]g\ 'UggYa V']b['hAY' gi ffc i bX' dUbY"

:][i fY' % . =bghU`]b['GdUWf' cbhc' Gi ffc i bX' DUbY"

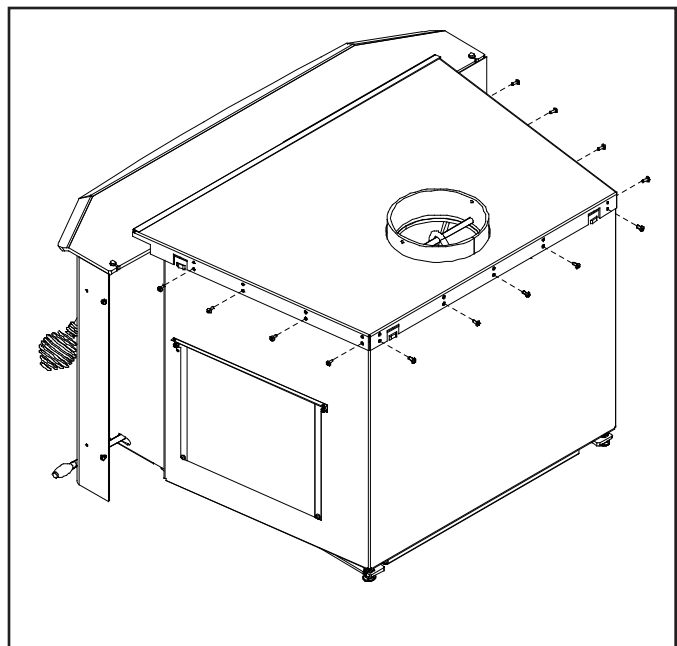

:][i fY' & \$. FYa cj]b['7UW]bYhHcd' Zfca '1 b]H'

=bgYfhI b]h

%": FYa cj Y' hAY' h.]fhYb' H & \$ gWYk g' \c'X]b['hAY' WU]bYhHcd']b' d'UW' ffYZf' hc':][i fY' & \$ E"

&": FYa cj Y' hAY' WU]bYhHcd' UbX' U]d']hcbhc']hg' hcd"

' "' FYa cj Y' hAY' 5]f' 8YUW]bYhHcd' fg\ck b']b':][i fY' & % E' VmfYa cj]b['hAY' h' c' f& E' H & \$ gWYk g'

(" FY!)bgU` hAY' WU]bYhHcd' cbhc' hAY' i b]h' hAY' gWYk' \c'Yg'Ucb['hAY' hcd' cZHAY' i b]hg\ci 'X' bck']bY' i d' k]h' hAY' hcd' gYhcz' \c'Yg'cb' hAY' WU]bYhHcd"

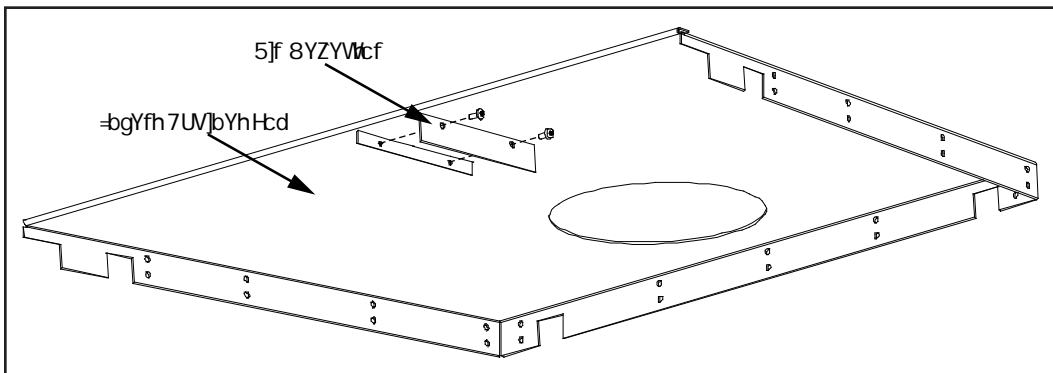

:][i fY' & % =bghU`]b['5]f' 8YUW]bYhHcd' cbhc' 7UW]bYhHcd"

=bghU` `Uh]c b

<95FH: DFCH97HCB 9L5AD@9G.

HUVY%% '9 Ua d'Yg'cZ<YUfH 'DUX'G]b['1 g]b['7YUfUbWg: fca 'HUV'Yg- / %\$ 'fFYZf'hc':][i fYg&&/ '&' t'

| | 7UbUXU | | I G5 | |
|---|--------------------|--------------------|--------------------|------------------|
| | %&\$\$ | %+\$\$ | %&\$\$ | %+\$\$ |
| f5t'A]b]a i a 'K]Xh | (\$ ' f%\$&, a a t | | ' * ' f' &* a a t | |
| f6t'A]b]a i a '8Ydh | (* ' f%\$*, a a t |)\$ ' f%&, ' a a t | (& ' f%\$* +a a t | (* ' f%\$ %a a t |
| CDH=CB5@! '7cfbYf'fYa cj U | | | | |
| f7t'A UI]a i a : fcbh7cfbYfg!' 5X'UWbh | , ' f' % (a a t | | * ' f%+ %a a t | |
| f8t'A UI]a i a '6UW'7cfbYfg!' 5X'UWbh | * ' f%\$ \$a a t | |) ' f% \$a a t | |
| f9t'A UI]a i a : fcbh7cfbYfg!' 8]U[cbU | %& ' f' % (a a t | | - ' f% (&a a t | |
| f1t'A UI]a i a '6UW'7cfbYfg!' 8]U[cbU | , ' f%&+a a t | | + ' f%) a a t | |
| f1t'A]b]a i a 'K]Xh 'fYa U]b]b['k]h'ci h'W'fbYfg!' : fcbh | & ' f') , ' a a t | | & ' f') , ' a a t | |
| fkt'A]b]a i a 'K]Xh 'fYa U]b]b['k]h'ci h'W'fbYfg!' '6UW | &+ ' f' t+\$+a a t | | &* ' f' t*) a a t | |

HUVY%& '9 Ua d'Yg'cZDUfU`Y` =bghU`Uh]cb'1 g]b['7YUfUbWg: fca 'HUV'Yg- / %\$ 'fFYZf'hc':][i fY'&&''

| | A cXY` | 7ci b]fm | fHt': Uf'9X[Y'cZ<YUfH 'DUX' hc'G]XY'K U`!'A]b]a i a | fHt': fcbhcZ<YUfH 'DUX'hc' 6UW'K U`!'A]b]a i a |
|--|--------|----------|---|---|
| G]b['Y'K U`'D]dY | %&\$\$ | 7UbUXU | () ' f' %\$ * a a t | (- ' f' %&) &a a t |
| | | I G5 | (' ' f' %\$ (a a t | (+ ' f' %&\$ %a a t |
| | %+\$\$ | 7UbUXU |) & ' f' % ' ' a a t |) (' f' % - %a a t |
| | | I G5 |) \$ ' f' %&, ' a a t |) & ' f' % (\$a a t |
| 8ci V'Y'K U`'D]dY | %&\$\$ | 7UbUXU | () ' f' %\$ * a a t | (, ' f' %&&* a a t |
| | | I G5 | (' ' f' %\$ (a a t | (* ' f' %\$+) a a t |
| | %+\$\$ | 7UbUXU | () ' f' %\$ * a a t |) & ' f' % (\$a a t |
| | | I G5 | (' ' f' %\$ (a a t |) \$ ' f' %&- \$a a t |
| 8ci V'Y'K U`'D]dY'k]h' <YUhi 9Z'U'Yb'W'G'Y'X') \$!%\$, , 'f' U'h'cd' a cXY`cb'nt | %&\$\$ | 7UbUXU | () ' f' %\$ * a a t | (* ' f' %\$+) a a t |
| | | I G5 | (' ' f' %\$ (a a t | ((' f' %&) a a t |
| | %+\$\$ | 7UbUXU | () ' f' %\$ * a a t |) \$ ' f' %&- \$a a t |
| | | I G5 | (' ' f' %\$ (a a t | (+ ' f' %&\$ % a a t |
| Hcd'j Yb'ci h' VUW'k U`'k]h' 'a]b]b['&(' f' t'\$a a t'j Yf'h]W' f]gY/'Xci V'Y'K U` | %&\$\$ | 7UbUXU | (* ' f' %\$ %a a t |) \$ ' f' %&+ +a a t |
| | | I G5 | ((' f' %&- a a t | (, ' f' %&&* a a t |
| | %+\$\$ | 7UbUXU | (' ' f' %\$ (a a t |)) ' f' % (%a a t |
| | | I G5 | (% ' f' %\$) ' a a t |) ' ' f' % (** a a t |

=bghU` Uh]c b

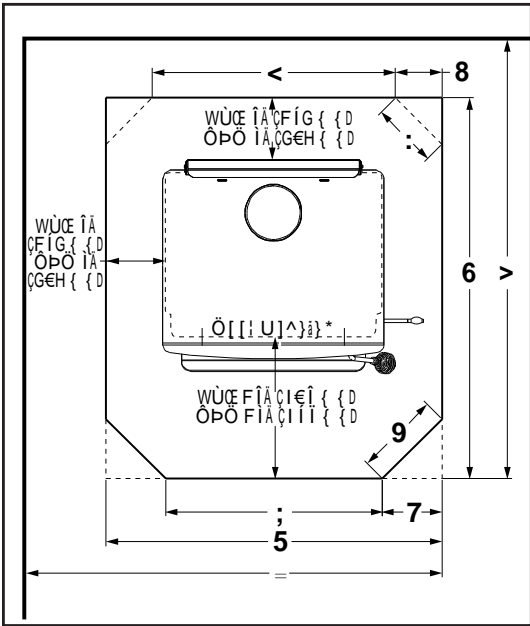

:][i fY' &&. ; YbYfU` DUfU` Y` =bghU` Uh]c b` fFYZf hc` HUV` Yg% %/ % &L'

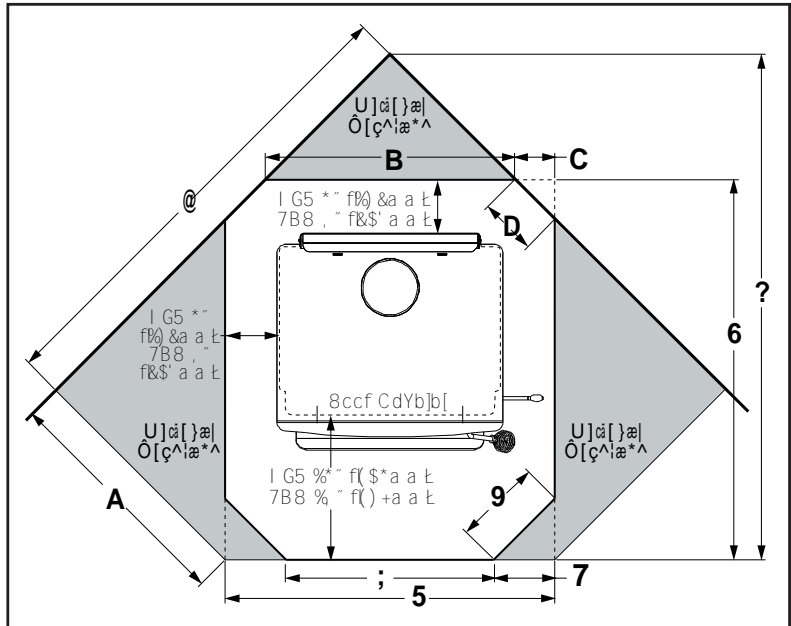

:][i fY' &. ; YbYfU` 7cfbYf` =bghU` Uh]c b` fFYZf hc` HUV` Yg% %/ % &L'

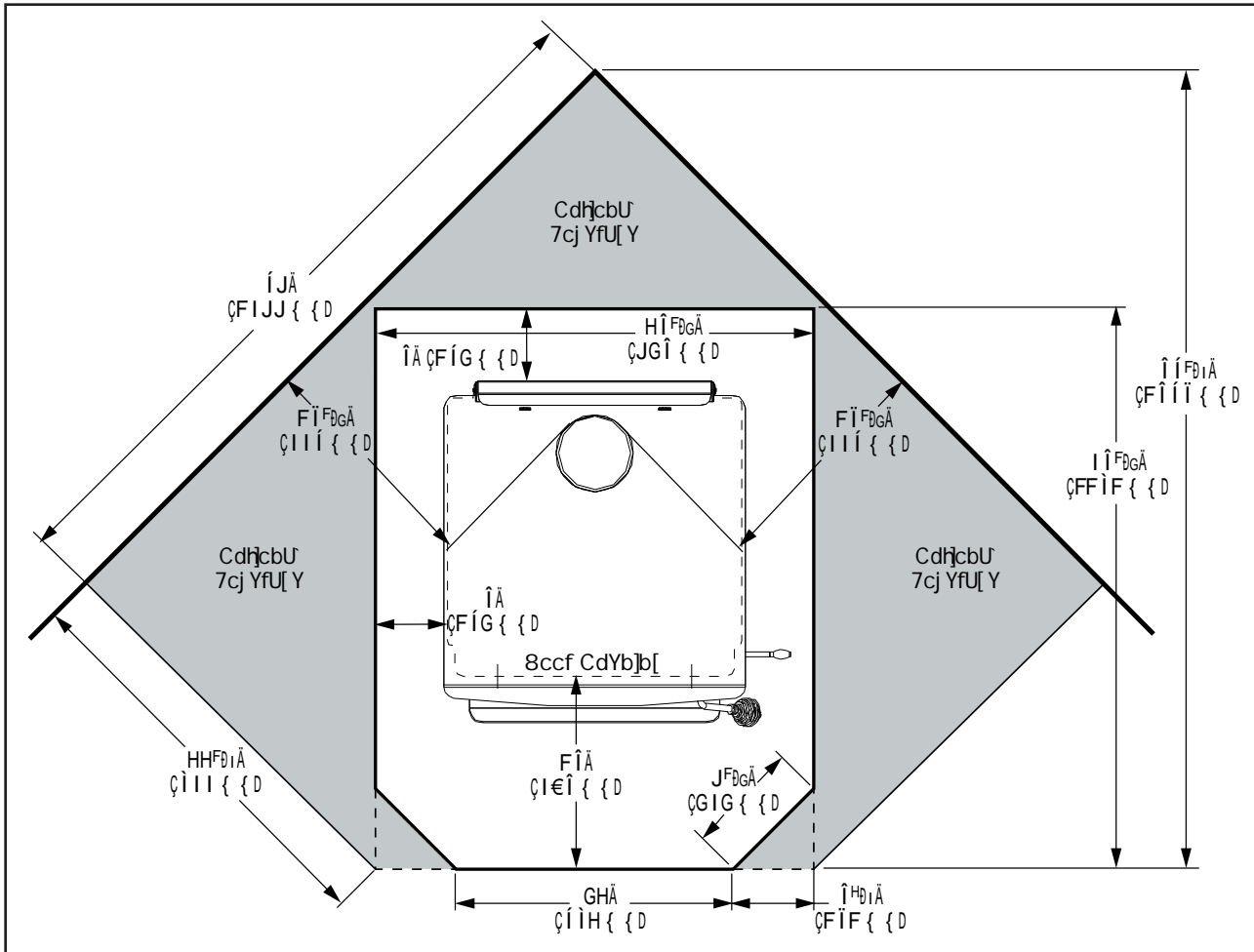

:][i fY' &(. 7cfbYf` =bghU` Uh]c b` Zcf% + \$\$]b l G5 i gjb['G]b['Y K U` D]dY fFYZf hc` HUV` Yg% \$Z% %/ % &L'

=bghU` `Uh]c b

HUVY% . 9I Ua d'Yg:cZ7cfbYf =bgTU` U]fcb i g]bI` 7YUFUbWg: fca` HUVYg- / %\$` fVYZf'fc: II i fYg& / &(L'

| G]bI` Y` K U` D]dY` | | fP`L: fcbhcZ <YUfFA` DUX`'fc` 7cfbYf` | fL` 5X`UWbhb K U` | fA`L`9X[Y`cZ <YUfFA` DUX`'fc` 5X`UWbhbK U` | fB`L`K`jA`'Uh` VUW`cZ<YUfFA` DUX` | fC`L`6UW`7cfbYf` FYa`cj`YX`' 8JU`cbU` | fD`L`6UW`7cfbYf` FYa`cj`YX`' 8JU`cbU` |
|------------------------|--------|---|-----------------------------|--|---|---|---|
| %&\$\$ | 7UbUXU | *%`i` fP`),`a`a`L` |)`+`i` fP`(`*`))`a`a`L` | &`i` fH`+`a`a`L` | '`\$`i` fH`+`+`a`a`L` | (`i` fP`&(`a`a`L` | +`i` fP`%`&a`a`L` |
| | I G5 |)`-`i` fP`\$`+`a`a`L` |)`(`i` fP`-`'`a`a`L` | &`i` fH`+`a`a`L` | '`(`i` fI`+`%`a`a`L` | i` fB`&`a`a`L` | %`i` fI`&a`a`L` |
| %+\$\$ | 7UbUXU | *`+`i` fP`+`\$`a`a`L` | *%`i` fP`+`%`a`a`L` | '`i` fI`((`a`a`L` | '`i`i` fI`)%`a`a`L` | '`i` fI`+`a`a`L` | (`i` fP`&`))`a`a`L` |
| | I G5 | *)`i` fP`*`+`a`a`L` |)`-`i` fP`(`-`a`a`L` | '`i`i` fI`((`a`a`L` | '`*`i` fI`*`a`a`L` | \$`i` fB`a`a`L` | \$`i` fB`a`a`L` |
| %&\$\$ | 7UbUXU |)`-`i` fP`&&a`a`L` |)*`i` fP`(`-`a`a`L` | &`i` fH`+`%`a`a`L` | &`+`i` fH`\$`+`a`a`L` | *`i` fP`*`\$`a`a`L` | '`i` fB`&`+`a`a`L` |
| | I G5 |)`+`i` fP`(`+`%`a`a`L` |)`'`i` fP`*`+`a`a`L` | &`i` fH`+`%`a`a`L` | '`%`i` fI`\$`-`a`a`L` | &`i` fI`-`a`a`L` | '`i` fI`+`a`a`L` |
| %+\$\$ | 7UbUXU | *)`i` fP`*`)(`a`a`L` | *`\$`i` fP`\$`'`'`a`a`L` | '`%`i` fI`\$`*`a`a`L` | &`i` fH`(`'`a`a`L` |)`i` fP`(`&`a`a`L` | +`i` fB`\$`%`a`a`L` |
| | I G5 | *`i`i` fP`*`\$`'`a`a`L` |)`+`i` fP`(`*`%`a`a`L` | '`%`i` fI`\$`*`a`a`L` | '`i`i` fI`(`)`a`a`L` | %`i` fI`(`%`a`a`L` | &`i` fI`-`a`a`L` |
| %&\$\$ | 7UbUXU |)`-`i` fP`&&a`a`L` |)*`i` fP`(`-`a`a`L` | &`i` fH`+`%`a`a`L` | &`+`i` fH`\$`+`a`a`L` | *`i` fP`*`\$`a`a`L` | '`i` fB`&`+`a`a`L` |
| | I G5 |)`i` fP`(`%`+`a`a`L` |)`&`i` fP`'`\$`a`a`L` | &`+`i` fH`+`%`a`a`L` | &`+`i` fH`\$`%`a`a`L` | (`i` fP`'`'`a`a`L` | *`i` fP`*`\$`a`a`L` |
| %+\$\$ | 7UbUXU | *)`(`i` fP`*`'`*`a`a`L` |)`-`i` fP`&`\$`a`a`L` | '`%`i` fI`-`(a`a`L` | &`+`i` fH`\$`+`a`a`L` | *`i` fP`*`\$`a`a`L` | '`i` fB`&`+`a`a`L` |
| | I G5 |)`-`i` fP`%`)(`a`a`L` |)`))`i` fP`-`+`a`a`L` | &`i` fH`(`'`a`a`L` | &`*`i` fH`*`))`a`a`L` |)`i` fP`%`\$`a`a`L` | +`i` fP`%`))`a`a`L` |

=b g h U ` ` Uh]c b

Ci HG-89'5f ?+H

h]g'a UbXUrcfmc'h: i gY'ci hg]XY Ujf'Zcf']bgtU`Uh]cbg]b'a cV]Y`ca Yg'
 5' (Í fP\$"& Vá E ZYg\ Ujf' UXUdhcf' _]h]g' Uj U]UVY" H\]g' UXUdhcf' VUb' VY'
]bgtU`YX' Y]hYf' cb' hY' VUW\ dYXYgU' cf' h'fci [\ ' hY' Úccf' i bXYf' hY'
 dYXYgU'" hY' Vá] Yf' d'UH' a i gh VY']bgtU`YX' cb' hY' i b]h]Z nci f' g'c] Y']g'
 `cVW]hX']b'U'a cV]Y`ca Y'cf']Zi g]b['ci hg]XY Ujf' Zca 'hY' Vchca "
 DUW`hY' Í'a Yg\ gV]Yb' VYh Yb' hY' ZYg\ Ujf' UXUdhcf' UbX' hY' VcXmcZ
 hY' dYXYgU' fUg'g'ck b' h' f] [\ h'

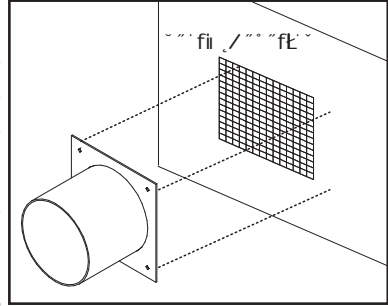

BCH9. : fYg\ Ujf' VbbY]cb' h' hY' i b]h]a i gh VY' U' bcb! Vá Vi gh]VY' d]dYž
 YI Ua d'Y. (Í fP\$"& Vá E' g]b['Y'k U' U' i a]bi a 'UYI' d]dY'

:] [i fY &) . : fYg\ '5]f' 5XUdhcf'
 c]b' h' hY' 6UW\ cZ hY' dYXYgU'"

BCH9. fYa c] Y' hY' Vá] Yf' d'UH' cb' hY' fYUf' cZ hY' dYXYgU']Z fcca 'Ujf']g' h' VY' i gYX' Zcf' Vá Vi gh]cb' Ujf'

F 97CAA 9B898 < 9= < HG: CF : @ 9'D=D9.

hY'a]b]a i a 'Úi Y'd]dY`Y] [\ h]Uh]gYU`Yj Y']g' % & ZYh'f] "+ a E' gh]U] [\ h]i d' Zca 'hcd' cZ hY' i b]h]': cf' Y] Yfm
 %\$ \$ \$ ZYh'f] \$) 'a E' Uvc] Y' gYU`Yj Yž' (i ' Vá' X' VY' UXXYX' h' hY' c] YfU`Y] [\ h]i gY' HUVYg' % (ž % ž UbX' % '
 h' VUW' UHY' hY' fYei]fYX' j Yfh]W' f]gY' fYei]fYX'

HUVY% (. FYVá a YbXYX' < Y] [\ h]Zcf' : 'i Y'D]dY"

| Ò çæö[]Á æà [ç^Á•^æÁ ç^ | Tā}ā { ~ { Á: ^ & [{ { ^ } á^á^ ~ ^Á]ā]^Á@^ā* @cÁ- [!ÁÁÁ [-Á^]ā [, • ÁÁÁÁÁÁÁÁ çP [c^kÁP [Á { [!^Ác@æ]ÁGÁ [-- • ^c• Áç I Á^]ā [, • DÁ&æ]Áá^Á ~ • áÉÁGç I Í » MFçJ€» | | | | | | |
|---------------------------------|---|----------|----------|----------|----------|----------|----------|
| ~^^c | € | GÁçÁFÍ » | IÁçÁFÍ » | GÁçÁHÉ » | IÁçÁHÉ » | GÁçÁÍÍ » | IÁçÁÍÍ » |
| €ÉF€€€ | FGÉ€ | FGÉĪ | FHÉH | FHÉH | FIÉĪ | FIÉ€ | FĪÉ€ |
| F€€€ÉG€€€ | FGÉÍ | FHÉG | FHÉĪ | FHÉĪ | FÍÉH | FIÉĪ | FĪÉĪ |
| G€€€ÉH€€€ | FHÉ€ | FHÉĪ | FIÉI | FIÉI | FÍÉJ | FIÉF | FĪÉH |
| H€€€ÉI€€€ | FHÉI | FIÉG | FIÉJ | FIÉJ | FĪÉÍ | FIÉĪ | FĪÉJ |
| I€€€ÉI€€€ | FHÉJ | FIÉĪ | FIÉI | FIÉI | FĪÉF | FIÉG | FĪÉĪ |
| í€€€Éí€€€ | FIÉI | FÍÉG | FĪÉ€ | FĪÉ€ | FĪÉĪ | FĪÉĪ | FJÉG |
| î€€€Éî€€€ | FIÉJ | FÍÉĪ | FĪÉÍ | FĪÉÍ | FĪÉG | FĪÉI | FJÉĪ |
| ï€€€Éï€€€ | FIÉI | FĪÉH | FĪÉ€ | FĪÉ€ | FĪÉĪ | FIÉJ | G€ÉÍ |
| ì€€€Éì€€€ | FIÉĪ | FĪÉĪ | FĪÉĪ | FĪÉĪ | FJÉI | FIÉÍ | GFÉF |
| J€€€ÉJ€€€€ | FIÉH | FĪÉH | FIÉF | FIÉF | G€É€ | FJÉ€ | GFÉĪ |
| { ^c^! • | € | GÁçÁFÍ » | IÁçÁFÍ » | GÁçÁHÉ » | IÁçÁHÉ » | GÁçÁÍÍ » | IÁçÁÍÍ » |
| €ÉHÉÍ | HÉĪ | HÉJ | IÉF | IÉF | IÉÍ | IÉH | IÉJ |
| HÉÍÉÍF€ | HÉĪ | IÉ€ | IÉG | IÉG | IÉĪ | IÉI | IÉF |
| ÍFÉÉJFÍ | IÉ€ | IÉG | IÉI | IÉI | IÉĪ | IÉĪ | IÉH |
| JFÍÉFGG€ | IÉF | IÉH | IÉĪ | IÉĪ | IÉ€ | IÉĪ | IÉÍ |
| FGG€ÉFÍGÍ | IÉG | IÉÍ | IÉĪ | IÉĪ | IÉG | IÉJ | IÉĪ |
| FÍGÍÉFÌH€ | IÉI | IÉĪ | IÉJ | IÉJ | IÉI | IÉF | IÉJ |
| FÌH€GFHÍ | IÉÍ | IÉĪ | IÉ€ | IÉ€ | IÉÍ | IÉH | IÉ€ |
| GFHÍÉGII€ | IÉĪ | IÉJ | IÉG | IÉG | IÉĪ | IÉÍ | IÉG |
| GII€ÉGĪII | IÉĪ | IÉF | IÉI | IÉI | IÉJ | IÉĪ | IÉI |
| GĪIIÉHÉI€ | IÉ€ | IÉH | IÉÍ | IÉÍ | IÉF | IÉĪ | IÉĪ |

HUVY% . 8]g]UbW' h' UXX' h' c]
 c] YfU`j Yfh]W' \ Y] [\ h'

| | 8]g]UbW' h' UXX | |
|--|-----------------|--------|
| Dufhi gYX | ZYh | a YHfg |
| () S'YVck | %\$ | \$" |
| -\$S'YVck | &"\$ | \$** |
| ÍHÍ | ' "\$ | \$"- |
| %Zch fB" a E'cZ \cf]ncb]U' fi b | &"\$ | \$** |

HUVY% . 9' Ua d'Yg'cZWW' Uh]b]
 c] YfU`j Yfh]W' \ Y] [\ h' fYei]fYX'

| | < Y] [\ h |
|--|---------------------|
| gYU`Yj Y'k]h' & I " \$S'YVck g' | % " ' Zhf (" % a E |
| cbYÍHÍ | ' "\$ Zhf\$ "- a E |
| % ' Zhf\$ " " a E' \cf]ncb]U' fi b | ' "\$ Zhf\$ "- a E |
| Hc]U' % | % " ' Zhf) "- a E |
| (\$\$\$!) \$\$\$ Zh fP&&\$! % &) a E' Uvc] Y' gYU`Yj Y' | % " - Zhf ("& a E |
| cbYÍHÍ | ' "\$ Zhf\$ "- a E |
| & Zhf\$ " " a E' \cf]ncb]U' fi b | (" ZhfP& a E |
| Hc]U' & | &\$ " - Zhf " " a E |

=bghU` Uh]c b

7<=AB9M=BGH5@5H=CB`HkFCi ; <`K 5@@

<YfY`UFY`Zci f`f(E`a`Yh`cXg`cZ`Vta`Vi`gh`VY`k`U`W`ja`bYm`Vt`bb`Vt`cf`dUgg`h`fci`[\`g`-`b`Z`fa`Uh]c`b`k`Ug`d`f`c]`j`Y`X`Z`ca`B`D5`&`%`

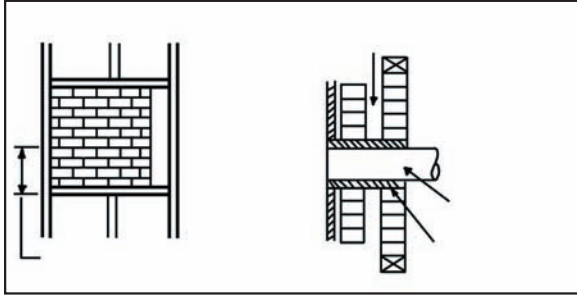

: [i fY`& . 7\]ja bYm`H`fci [\`K`U`!`A`Yh`cX`5`"

A Yh`cX`5` " & i f`\$` ,`a`a`E`7`YUf`UbW`hc`7`ca`Vi`gh`VY`K`U`A`Ya`Vf` . I`glb`[`U`a`]`ja`i`a`h`M`b`Y`gg`")`I`f`-`a`a`E`Vf`W`UbX`U`I`f`l`-`a`a`E`a`]`ja`i`a`k`U`h`]`W`b`Y`gg`W`Um`]`b`Y`f`V`b`g`f`i`V`U`k`U`d`Ugg`h`f`ci`[\`H`Y`W`Um`]`b`Y`f`a`i`gh`V`b`Z`fa`hc`5`G`H`A`7`%`f`G`H`b`X`U`F`X`G`d`Y`V`U`M`h`c`b`Z`c`f`7`Um` :`j`Y`@`]`b`[`g`c`f`]`j`g`Y`e`i`j`U`Y`b`h`" ?`Y`d`U`a`]`ja`i`a`c`Z`%`&`i`f`\$` ,`a`a`E`c`Z`Vf`W`a`U`g`c`b`f`m`V`Y`k`Y`b`h`Y`W`Um`]`b`Y`f`U`b`X`k`U`V`ta`Vi`gh`V`Y`g`" H`Y`W`Um`]`b`Y`f`g`U`f`i`b`Z`ca`h`Y`Vf`W`a`U`g`c`b`f`m`c`i`h`f`g`i`f`Z`W`hc`h`Y`]`b`b`Y`f`g`i`f`Z`W`c`Z`h`Y`W`ja`b`Y`m`U`i`Y`]`b`Y`f`Vi`h`b`c`h`d`U`g`h`h`Y`]`b`b`Y`f`g`i`f`Z`W`" :`j`fa`m`]`f`ci`h`c`f`W`a`Y`b`h`h`Y`W`Um`]`b`Y`f`]`b`d`U`W`hc`h`Y`W`ja`b`Y`m`U`i`Y`]`b`Y`f`"

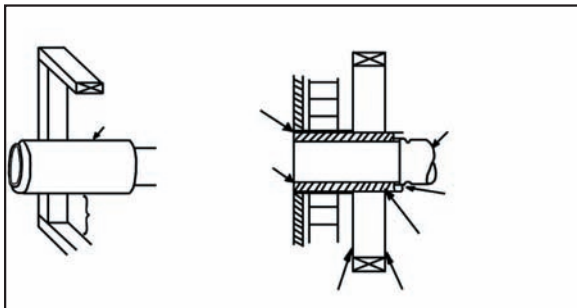

: [i fY`&+ . 7\]ja bYm`H`fci [\`K`U`!`A`Yh`cX`6`"

A Yh`cX`6` " -I`f`&-`a`a`E`7`YUf`UbW`hc`7`ca`Vi`gh`VY`K`U`A`Ya`Vf` . I`glb`[`U`a`]`f`l`&`a`a`E`]`bg`j`X`Y`X`]`U`a`Y`h`f`Z`Z`M`f`c`f`m`Vi`j`h`G`c`]`X`!`DU`_`W`ja`b`Y`m`g`V`]`c`b`k`]`h`]`b`g`i`U`h`c`b`c`Z`%`f`&`" (`a`a`E`c`f`a`c`f`Z`Vi`j`X`U`k`U`d`Ugg`h`f`ci`[\`k`]`h`U`a`]`ja`i`a`-`I`f`&-`a`a`E`U`j`f`g`d`U`W`V`Y`k`Y`b`h`Y`ci`h`f`k`U`c`Z`h`Y`W`ja`b`Y`m`Y`b`[`h`U`b`X`k`U`V`ta`Vi`gh`V`Y`g`" I`g`Y`g`Y`h`a`Y`H`U`g`i`d`d`c`f`h`Z`j`g`h`b`Y`X`g`Y`W`f`Y`m`i`r`c`k`U`g`i`f`Z`W`g`c`b`U`g`j`X`Y`g`hc`a`U`]`b`U`]`h`Y`-`I`f`&-`a`a`E`U`j`f`g`d`U`W`" `K`Y`b`Z`j`g`h`b`[`g`i`d`d`c`f`h`hc`W`ja`b`Y`m`Y`b`[`h`Z`X`c`b`c`h`d`Y`b`Y`f`U`h`h`Y`W`ja`b`Y`m`]`b`Y`f`f`h`Y`]`b`g`j`X`Y`k`U`c`Z`h`Y`G`c`]`X`!`DU`_`W`ja`b`Y`m`" H`Y`]`b`b`Y`f`Y`b`X`c`Z`h`Y`G`c`]`X`!`DU`_`W`ja`b`Y`m`g`V`]`c`b`g`U`V`U`i`g`k`]`h`h`Y`]`b`g`j`X`Y`c`Z`h`Y`a`U`g`c`b`f`m`W`ja`b`Y`m`U`i`Y`U`b`X`g`Y`U`Y`X`k`]`h`U`b`c`b`k`U`h`f`g`c`i`V`Y`f`Y`Z`U`M`f`c`f`m`W`a`Y`b`h`" I`g`Y`h`j`g`W`a`Y`b`h`hc`U`g`c`i`g`U`hc`h`Y`Vf`W`a`U`g`c`b`f`m`d`Y`b`Y`f`U`h`c`b`"

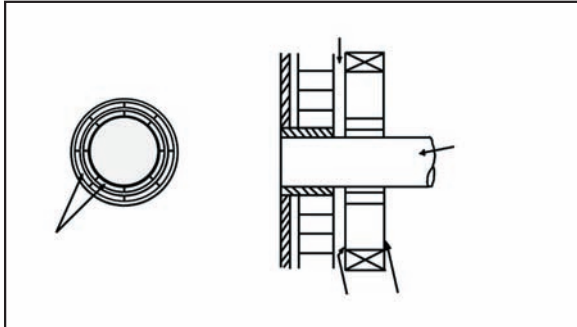

: [i fY`& . 7\]ja bYm`H`fci [\`K`U`!`A`Yh`cX`7`"

A Yh`cX`7` " *I`f`l`&`&` (`a`a`E`7`YUf`UbW`hc`7`ca`Vi`gh`VY`K`U`A`Ya`Vf` . G`H`U`h`]`k`]`h`U`a`]`ja`i`a`&`([`U`i`[`Y`f`\$`&`I`O`" `a`a`O`*`I`f`l`&`&` (`a`a`E`a`Y`H`W`ja`b`Y`m`V`t`b`b`V`t`cf`U`b`X`U`a`]`ja`i`a`&`([`U`i`[`Y`j`Y`b`h`]`U`h`Y`k`U`h`ja`V`Y`k`]`W`U`g`h`k`c`U`j`f`W`U`b`b`Y`g`c`Z`%`f`&`" (`a`a`E`Y`U`W`Z`V`t`b`g`f`i`V`U`k`U`d`Ugg`h`f`ci`[\`H`Y`f`g`U`V`Y`U`a`]`ja`i`a`*`I`f`l`&`&` (`a`a`E`g`d`U`f`U`h`c`b`U`f`Y`U`V`t`b`U`]`b`[`U`V`Y`f`U`gg`]`b`g`i`U`h`c`b`Z`Z`ca`h`Y`ci`h`f`g`i`f`Z`W`c`Z`h`Y`k`U`h`ja`V`Y`hc`k`U`V`ta`Vi`gh`V`Y`g`" G`i`d`d`c`f`h`h`Y`k`U`h`ja`V`Y`U`b`X`W`j`Y`f`]`j`g`c`d`Y`b`[`k`]`h`U`&`([`U`i`[`Y`a`]`ja`i`a`g`Y`h`a`Y`H`U`g`i`d`d`c`f`h`A`U`]`b`U`]`h`Y`*`I`f`l`&`&` (`a`a`E`g`d`U`W`" H`Y`f`g`U`c`i`X`U`g`c`V`Y`U`g`i`d`d`c`f`h`g`h`Y`X`hc`U`h`U`b`X`V`c`X`h`Y`a`Y`H`U`W`ja`b`Y`m`V`t`b`b`V`t`cf`" G`Y`h`U`h`h`Y`g`i`d`d`c`f`h`U`f`Y`Z`j`g`h`b`Y`X`g`Y`W`f`Y`m`i`r`c`k`U`g`i`f`Z`W`g`c`b`U`g`j`X`Y`g`" A`U`_`Y`g`i`f`Y`Z`j`g`h`b`Y`f`g`i`g`Y`X`hc`g`Y`W`f`Y`h`Y`a`Y`H`U`W`ja`b`Y`m`V`t`b`b`V`t`cf`X`c`b`c`h`d`Y`b`Y`f`U`h`W`ja`b`Y`m`U`i`Y`]`b`Y`f`"

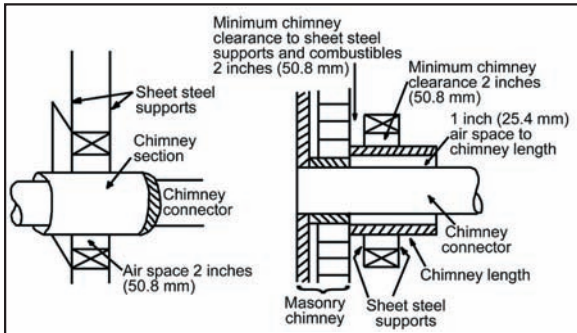

: [i fY`&- . 7\]ja bYm`H`fci [\`K`U`!`A`Yh`cX`8`"

A Yh`cX`8` " & i f`\$` ,`a`a`E`7`YUf`UbW`hc`7`ca`Vi`gh`VY`K`U`A`Ya`Vf` . G`H`U`h`k`]`h`U`g`c`]`X`!`DU`_`]`g`h`Y`Z`Z`M`f`c`f`m`Vi`j`h`W`ja`b`Y`m`g`V`]`c`b`U`h`Y`U`g`h`%`&`i`f`l`\$` (`a`a`E`c`b`[`Z`k`]`h`]`b`g`i`U`h`c`b`c`Z`%`f`&`" (`a`a`E`c`f`a`c`f`Z`U`b`X`U`b`]`b`g`j`X`Y`X`]`U`a`Y`h`f`c`Z` ,`I`f`&`O`%`a`a`O`U`f`[`Y`f`h`U`b`h`Y`*`I`O`&` (`a`a`O`Q`W`ja`b`Y`m`V`t`b`b`V`t`cf`" I`g`Y`h`j`g`U`g`U`d`Ugg`h`f`ci`[\`Z`c`f`U`a`]`ja`i`a`&`([`U`i`[`Y`g`]`b`[`Y`k`U`g`h`Y`W`ja`b`Y`m`V`t`b`b`V`t`cf`" ?`Y`d`g`c`]`X`!`DU`_`g`Y`V`]`c`b`V`t`b`W`b`h`f`W`k`]`h`U`b`X`g`d`U`W`X`%`f`&`" (`a`a`E`c`Z`h`Y`W`ja`b`Y`m`V`t`b`b`V`t`cf`V`m`k`U`m`c`Z`g`Y`h`i`a`Y`H`U`g`i`d`d`c`f`h`d`U`h`g`U`h`V`c`h`Y`b`X`g`c`Z`W`ja`b`Y`m`g`V`]`c`b`" `7`c`j`Y`f`c`d`Y`b`[`Z`U`b`X`g`i`d`d`c`f`h`W`ja`b`Y`m`g`V`]`c`b`c`b`V`c`h`g`j`X`Y`g`k`]`h`&`([`U`i`[`Y`a`]`ja`i`a`g`Y`h`a`Y`H`U`g`i`d`d`c`f`h`" G`Y`h`U`h`h`Y`g`i`d`d`c`f`h`U`f`Y`Z`j`g`h`b`Y`X`g`Y`W`f`Y`m`i`r`c`k`U`g`i`f`Z`W`g`c`b`U`g`j`X`Y`g`" A`U`_`Y`g`i`f`Y`Z`j`g`h`b`Y`f`g`U`f`i`g`Y`X`hc`g`Y`W`f`Y`W`ja`b`Y`m`U`i`Y`]`b`Y`f`"

BCH9G

%`7`c`b`b`V`t`c`f`g`hc`U`a`U`g`c`b`f`m`W`ja`b`Y`m`Y`i`W`d`h`[`a`Y`h`c`X`6`Z`g`U`Y`i`h`r`b`X`]`b`c`b`Y`V`t`b`h`bi`ci`g`g`V`]`c`b`h`f`ci`[\`h`Y`k`U`d`Ugg`h`f`ci`[\`g`n`g`h`Y`a`U`b`X`h`Y`W`ja`b`Y`m`k`U`Z`hc`Vi`h`b`c`h`d`U`g`h`h`Y`]`b`b`Y`f`U`i`Y`]`b`Y`f`Z`W`" &`"5`W`ja`b`Y`m`V`t`b`b`V`t`cf`g`U`b`c`h`d`U`g`h`f`ci`[\`U`b`U`h`h`c`f`f`c`c`Z`g`d`U`W`Z`V`t`c`g`Y`h`c`f`g`ja`]`U`f`V`t`b`W`U`Y`X`g`d`U`W`Z`c`f`U`U`c`c`f`c`f`W`]`b`[`"

=bghU` `Uh]c b

=BGH5@5HCB C: 5'@GH98Ž: 57HCFM6i =@H7<=AB9M! : F99GH5B8=B; .

H [g]g'U [YbYf]WgYhcZ]bgrfi V]cbg/U'k UngZc`ck 'hY'W]a bYma Ubi ZUMi fyf]bgrfi V]cbg' YI d']V]hri'5'gc'fYZf'hc'Í F 97CAA 9B898 < 9= <HG: CF : @ 9'D=D9I''

%: GYh'Úccf' dfchV]tcf' UbX' gncj Y']b' `cW]h]cb']b' UWtfxUbW' k]h' hY' Í 7@95F5B79G' Hc' 7CA6I GH-6@G' ! '%&\$\$' : F99GH5B8=B; Í' cf' Í 7@95F5B79G' Hc' 7CA6I GH-6@G' ! %&\$\$: F99GH5B8=B; Í''

&'' A Uf_ hY' dcl]h]cb' Zcf' hY' W]]b[' \cY' Vm gi gdYbX]b[' U' d'ia V' VcV' Zfca' hY' W]]b[' cj Yf' hY' YI UMi Wbhyf' cZ mef' f' gncj Y' Úi Y' UbX' a Uf_ U' gclh]cb' hY' W]]b[' hc']bX]W]hY' hY' Wbhyf' cZ hY' W]]a bYm''

' '' A c j Y' h']g' `cW]h]cbž']Z bYWggUfnā' hc' Uj c]X' Úccf' `c]g]gž' W]]b[' fUZ]Yfgž' Y' YM]W] k]f]b[' UbX' d'ia V]]b[' k \]Y' g]'' a U]]b]]b]]b[' fYei]fYX' W]UfUbWg'' =Z Úccf' `c]g]g' cf' W]]b[' fUZ]Yfg' a i ghVY' W]h' hY' Yma i ghVY' a UXY' g]f]i V] fU' m gci bX' U[U]]b'' =bghU'' W]]a bYm' UWtfx]b[' hc' W]]a bYm' a Ubi ZUMi fyfg']bgrfi V]cbg'' 5' W]]a bYm' VtbbYV]tcf' V]]bcbch' dUgg' h' fci [\ ' Ub' U]h]W' cf' fccZ' gdUWž' V]cgyh' cf' g]a]Uf' VtbbWU]YX' gdUWž' cf' U' Úccfž' W]]b[' ž' k U'' cf' dUf]h]cb' cZ Vtā Vi gh]VY' Vtbbgrfi V]cb'' =b' 7UbUXUž']Z dUggU[Y' h' fci [\ ' U' k U'' cf' dUf]h]cb' cZ Vtā Vi gh]VY' Vtbbgrfi V]cb']g' XYg]fYXž' hY']bgrU' U]h]cb' g' U'' VtbbZcfa' hc' 75B#7G5! 6' *) =bghU' U]h]cb' 7cXY' Zcf' Gc']X! : i Y' 6i fb]b[' 5dd']UbWg' UbX' 9ei]da Ybh' UbX' B: D5' &%%GHUbXUfX' Zcf' 7\]a bYngž:]fYd' UWgž' JYbhgž' UbX' Gc']X: : i Y' 6i fb]b[' 5dd']UbWg'

('' A Uf_ hY' \cY' Zcf' hY' 'ci h]jXY' U]f' _]h')'' A c j Y' h' Y' gncj Y' 'ci hcZ hY' k Umi *'' 7i h' U' d]]ch' \cY']b' hY' W]]b['' +'' 7i h' U' \cY' Zcf' hY' W]]b[' dYbYf]h]cb' Vtā dcbYbhj' UbX' ZUa Y']b' hY' g]XYg' cZ hY' \cY']b' Vch' hY' W]]b[' UbX' fccZ' 7\ YWž' UbX' Zc`ck' W]]a bYm' a Ubi ZUMi fyf]g']bgrfi V]cbg' Zcf' U'' cZ hY' YgY' ghYdg' ,'' =bghU'' hY' gi ddcfh' Vcl' UbX' W]]a bYm' h' fci [\ ' hY' fccZ' =bghU'' hY' g]d' gYV]cb' Zcf' hY' W]]a bYm' VtbbYV]tcf''

-'' G]d' hY' fccZ' ÚUg\]b[' c j Yf' hY' W]]a bYm' UbX' gYW'fY' hc' hY' fccZ' VY]b[' W]fYž' '' hc' _Yyd' hY' d]dY' WbhyfYX']b' hY' cdYb]b['' Hc' a YYh' hY' VtX]Yž' hY' W]]a bYm' a i gh' YI hY' bX' U' Vc j Y' hY' fccZ' dYbYf]h]cb' U]h' Y' Ugh' ' ' ZYh' f' f' %(' Vā Lž

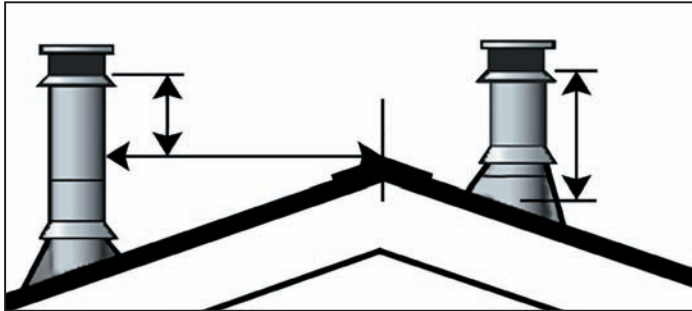

:]i fY' \$' FccZ7' YUfUbWg'

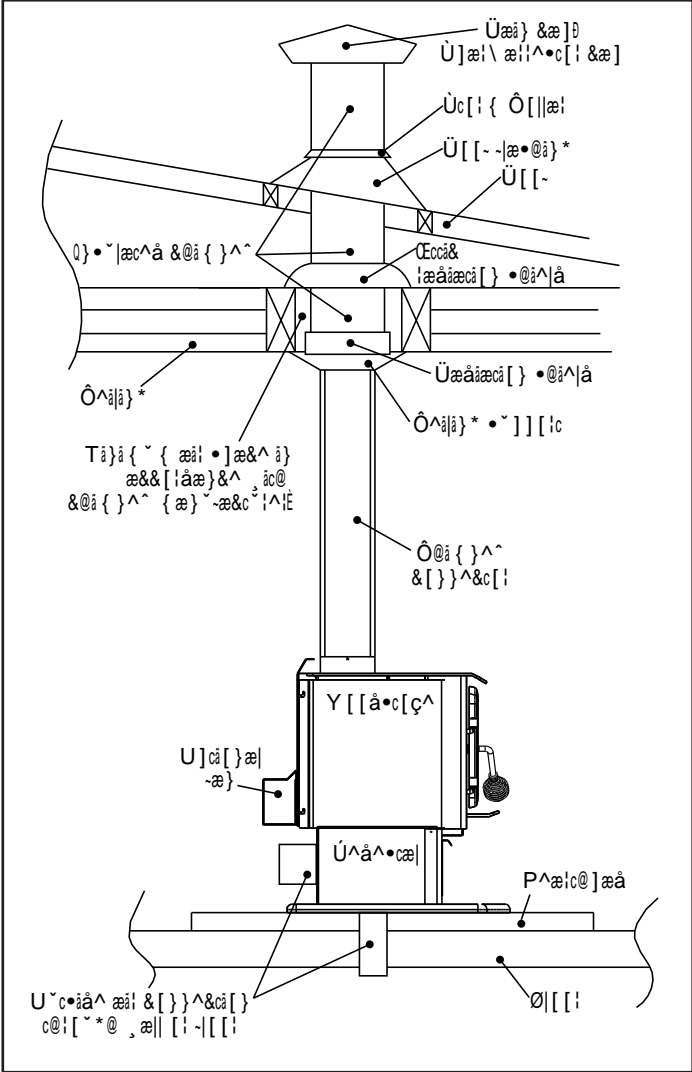

:]i fY' %' GHUbXUfX' JYf]h]W' =bghU' U]h]cb''

=bghU` `Uh]c b

UbX`]b` UbmUfYU` k`]h`]b` %\$` ZYh`
 fl` \$(`,` ` Vá` É` cZ` hY` fccZ` f]X[` Yž`
 hY` V]a` bYm` a` i` gh` VY` &` ZYh`
 ff` \$`-` ` Vá` É` Uvcj` Y` hY` f]X[` Y`
 FYZf` hc` :`]i` fY` ` \$`

BchY. ` =bVfYUg]b[` hY` V]a` bYm`
 \Y][` \h` Uvcj` Y` hY` fccZ` a` Um`
 \Yd` nci` f` i` b]h` hc` XfUZh` VYhYf`
 H`]g[` fYUhf` XfUZh` V]b` XvVfYUgY`
 dfcVYa` g` gi` V]` Ug` X]ZUW` h`
 ghUfh` dgž` ga` c_Y` V]a`]b[` ci` h`
 k` \Yb` Xccf`]g` cdYbž` UbX` X]f]m`
 [`Ugg` ` Mti` ` a` Um`]b]h]U` m` hf`
 hY` a`]b]a` i` a` fYei`]fYX` \Y][` \h`
 UbX`]Z` dfcVYa` g` Xc` Uf]gYž` UXX`
 UXX]h]cbU` \Y][` \h` Uhf`

%\$` G]XY` hY` fccZ` U]g\`]b[` cj` Yf`
 nci` f` V]a` bYm` UbX` gYU` hY`
 U]g\`]b[` hc` hY` fccZ` k]h` U`
 fccU]b[` V]a` dci` bX` GYWFY` hY`
 fccZ` U]g\`]b[` hc` nci` f` fccZ` k`]h`
 bU]g` cf` gVfYk` g`

%&` D`UW` hY` g]cfa` V]` Uf` cj` Yf` hY`
 U]g\`]b[` UbX` gYU` hY` c]b]g`
 k`]h`]g]V]bY` V]i` `]b[`

%&` UghYb` hY` fU]b` V]d` #` gdUf`
 UffYg]cf` V]d` hc` hY` hc` cZ` nci` f`
 V]a` bYm`

%` D`UW` hY` g]c]Y` VUW`]b]c`
 d]cg]h]cb`

%(` =bghU` hY` V]a` bYm` V]bbYV]cf` d]dY` k`]h` hY` ck` Yf` fV]a` dYXÉ` YX[` Y` cZ` hY` d]dY`]bg]XY` hY` U]i` Y` V]` Uf`
 5bm` V]Ycg]hY` Zcfa` YX` k`]` hYb` fi` b` VUW` Xck` b`]b]c` hY` g]c]Y` 5` V]bbYV]cbg` a` i` gh` VY` h]` \h` UbX`
 gYWFYX` k]h` hYfY` gY` Yha` YH` gVfYk` gYei` U` mgdUWX` 8ci` VY` k` U` d]dY`]g` fYV]a` a` YbYX` c]Yf` g]b[` Y`
 k` U`

%` 5` gc`]bg]U` Ub` ci` hg]XY` U]f` U]i` d]dY` hc` hY` g]c]Y` Y`

=ADCFH5BH ` K` \Yb` U` a` YH` dfYZUf]V]hYX` V]a` bYm]g` i` gYXž` hY` a` Ubi` ZUM` fYf]g]]bg]U` Uh]cb`]bg]fi` V]cbg`
 a` i` gh` VY` Z` ck` YX` Mti` a` i` gh` Ugc` di` fV]UgY` UbX`]bg]U` hY` W]]b[` gi` ddcf]h` dUWU[` Y` cf` k` U` dUgg] h]fci` [` \`
 UbX` [H]` gYV]cb` dUWU[` Yž` UfYg]cdg` fk` \YfY` bYXYXž`]bg` Uh]cb` g\` Y` Xž` fccZ` U]g\`]b[` ž` V]a` bYm` V]dž` YH` V`
 A` U]b]h]b` dfcdYf` V]UfUbW` hc` hY` g]fi` V]i` fY` Ug` fYV]a` a` YbYX` Vm]hY` a` Ubi` ZUM` fYf` hY` V]a` bYma` i` gh` VY`
 hY` fYei`]fYX` \Y][` \h` Uvcj` Y` hY` fccZ` cf` chYf` cVg]fi` V]cbg` Zc` g]Z]f]m` UbX` dfcdYf` XfUZh` cdYf` U]h]cb`

BchY. ` =Z` nci` UfY` i` g]b[` U` cf]ncb]U` V]bbYV]cf` fYfYf` hc` :`]i` fY` ` &ž` hY` W]a` bYm` V]bbYV]cf`
 g]ci` X` VY` Ug` \][` \` Ug` d]cgg]VY` k` \]Y` gh` ` a` U]b]h]b]b[` hY` %` Î` f` (+)` a` a` É` a`]b]a` i` a`
 X]ghUbW` Zcfa` hY` \cf]ncb]U` V]bbYV]cf` hc` hY` W]]b[`

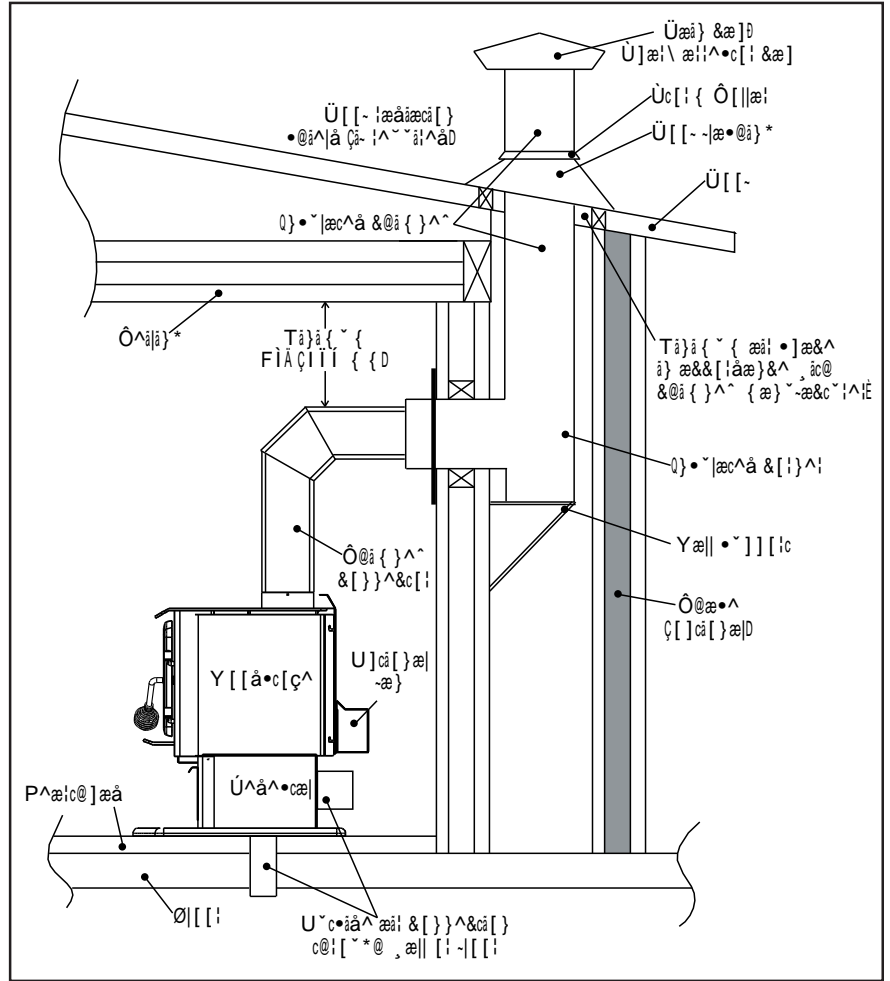

:]i` fY` ` &` Gh]bXUfX` <cf]ncb]U` =bghU` Uh]cb`

=bgH U` Uh]c b

A 5GCBFM7 < =AB9M =BG5@5H=CB ! : F 99GH5B8=B; .

8C BCH7CBB97H'H< =G'I B=HHC 5'7< =AB9M: @ 9'G9F J =B; '5BCH< 9F '5DD@=5B79'

5' bcb! Vta Vi gh]VY' Uccf' dfchVtcf']g' fYei]fYX' i bXYF' U'' ZYVgUbx]b[' i b]rg' fYZf' hc' Í 7@5F5B79G' Ht' 7CA6I GH=6@G' ! %&\$\$: F99GH5B8=B; Í 'cf' Í 7@5F5B79G' Ht' 7CA6I GH=6@G' ! %+\$\$: F99GH5B8=B; Í ''K \Yb' j Ybh]b[']brc' U' a UgcbfmW]a bYnã'hY' Uccf' dfchVtcf' a i ghVY']bgH' U' YX' X]fYVtM' VY' ck' hY' W]a bYmj YbhUbx' &Í' f) \$", 'a a E' cb' Y]h' Yf' g]XY' cZ' hY' W]a bYmj Ybh'

JYbh' hY' gHc] Y']brc' U' VWUbx']bYXz' Uddfcj YX' a UgcbfmW]a bYm]b[[ccX' VtbX]h]cbz' VtbZcfa]b[' hc' 'cW' Vi]X]b[' VtXYg' UbX' a YH]b[' hY' a]b]a i a' gHbXUfXg' cZ' hY' BUH]cbU' :]fY' DfchVtcf' cb' 5ggcV]U]cb' fB: D5L'' AU_Y' g] fY' hY' fY' UfY' bc' VWUW' gz' 'ccgY' a cftUf' cf' chYf' g] [bg' cZ' XYHf]cfU]cb' UbX' V'cWU] Y'' <Uj Y' hY' W]a bYmVWUbx' VYzcf' hY' gHc] Y']g']bgH' U' YX' UbX' cdYfUHYXz' cf' j Ybh' k]h' U']ghYX' *Í' fP) \$' a a E' ZUMtcf' h' Vi]h' W]a bYmj]HUV' Y' Zcf' i gY' k]h' gc']X' Z' Y' g' UbX' VtbZcfa]b[' hc' ! @! G* &- 'GHbXUfX' Zcf' '*') \$š7' ZUMtcf' h' 6i]h' 7\]a bYng']b' 75B585' cf' ! @%\$' <H: UMtcf' h' 6i]h' 7\]a bYng' Zcf' FYg]XYbh]U' H' h' Y' UbX' 6i]X]b[' <YU]b[' 5dd]UbWg']b' hY' ! "G"5" 7cbbVtM' hY' gHc] Y' hc' h']g' W]a bYmk]h' U' g' cfi UbX' g' fU] [\h' *Í' fP) \$' a a E' z' &([U] [Y' cf' \YU]]fz' g]b[' Y! k U' V' UW' cf' V' i YX' ghY' 'ga c_Y' d]dY'' 7cbbVtM]cb' hc' U' a UgcbfmW]a bYng' a i gh' VY' U' a YH' U' cf' a Ugcbfmh']a VY' W' a YbhYX']b' d' UW'' 5'' ga c_Y' d]dY' g' a i gh' g' cdY' i dk' UfXg' z' U' VtbbVtM]cbg' a i gh' VY' h] [\h' UbX' g' YW' fYX' k]h' h' fY' g' VY' h' a YH' U' g' VY' g' Yei U' mgdUWX'' hY' ga c_Y' d]dY' 'Yb[h' g' ci' X' bchY' WYX' (\$i' cZ' hY' W]a bYm\Y] [\h' U' Wc] Y' hY' gHc] Y''

K \Yb' VtbbVtM]b[hY' gHc] Y' h' fci [\ U' Vta Vi gh]VY' k U' 'hc' U' a UgcbfmW]a bYnã' UXX]h]cbU' g' h' Y' dg' UfY' fYei]fYX'' 7c]b] 'h' hY' W]a bYm' VtbbVtcf' a Ubi ZUM' fYf' UbX' fYZf' hc' :] [i fY'' ("

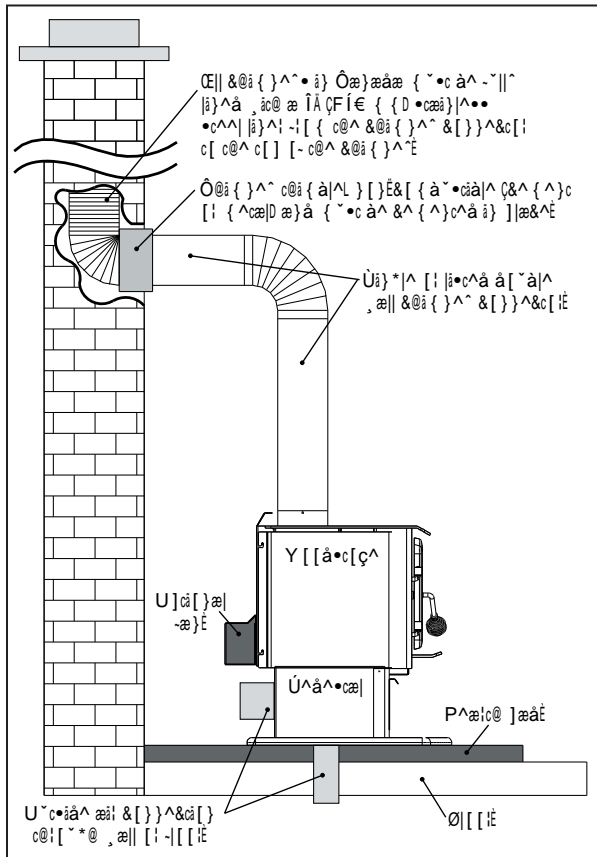

:] [i fY'' . =bgH U]h]cb]brc' U' a UgcbfmW]a bYnã'

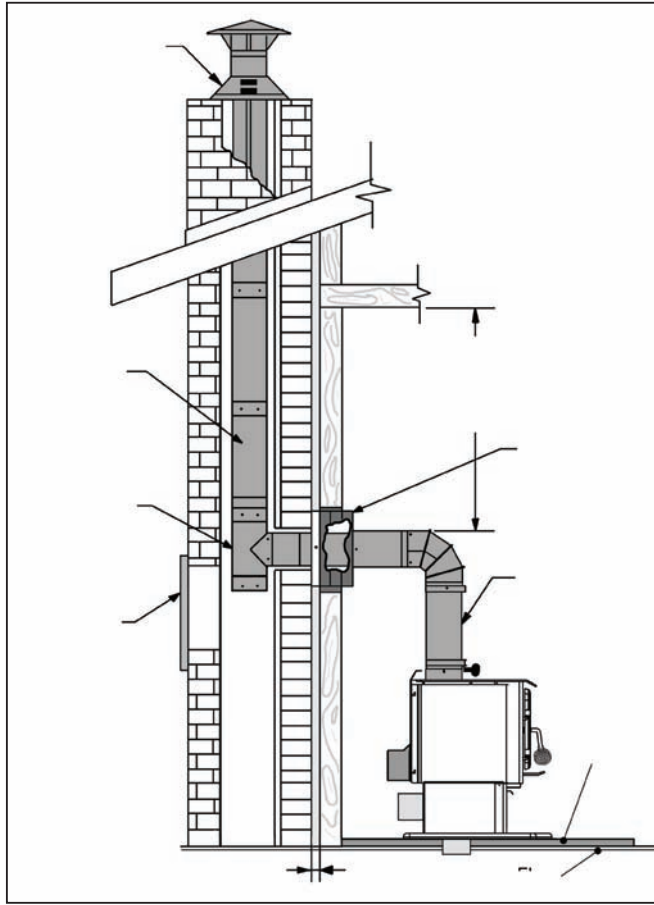

:] [i fY'' (. =bgH U]h]cb]brc' W]a bYmã' h' fci [\ U' Vta Vi gh]VY' k U''

=bghU` `Uh]c b

A 5GCBFM: =F 9D@579` =BGH5@5H-CB ! : F 99GH5B8-B; .

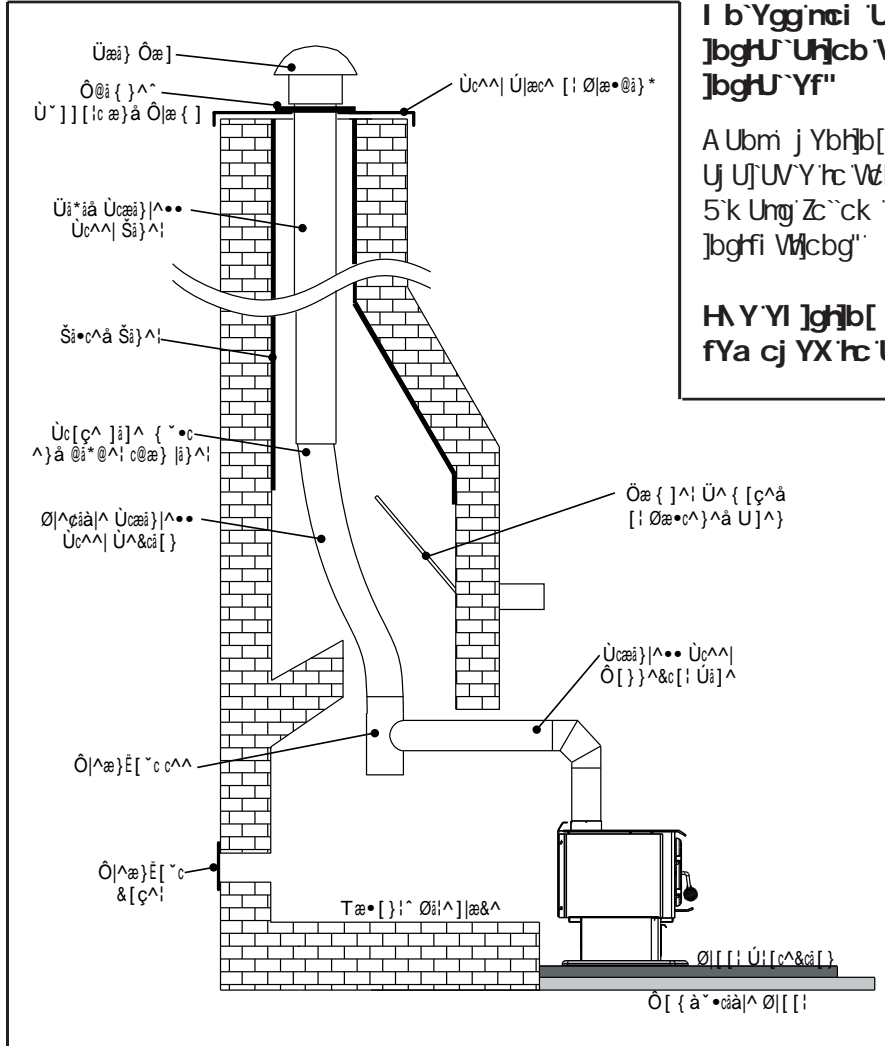

I b`Ygg`nci `UFY`YI dYf]YbWXžk Y`fYVta a YbX`
]bghU`Uh]cb Vmnci f`XYUYf`cf`U`dfcZYgg]cbU`
]bghU`Yf`"

A Ubrn j Ybh]b[` a Ubi ZMM fYfg: \Uj Y`]ghYX` _]hg`
 Uj U]UVY`hc`VtbbYVMU`g`c`j Y`hc`U`a UgcbfmÚFYd`UW`"
 5`k Unq`Zc`ck`h`Y`j Ybh`a Ubi ZMM fYfg`]bghU`Uh]cb`
]bghU`V]cbg`"

H`Y`YI]gh]b[`XUa dYf`a Um\ Uj Y`hc`VY`
 fYa cj YX`hc`U`ck`]bghU`Uh]cb`"

:] [i fY`) . : fYfgUbx]b[=bghU`Uh]cb]bhc`YI]gh]b[`ÚFYd`UW`"

A C6=@` < CA 9` =BGH5@5H-CB.

GD97`-5@F 9E I =F 9A 9BHG. `DYXgU`a cXY`g`%&\$\$`UbX`%+\$\$`UFY`Uddfcj YX`Zcf`a cV]Y` \ca Yg`" 5`%&\$\$`
 cf`%+\$\$` =bgYfh`a UmUgc`VY`]bghU`YX`]bhc`U`A cV]Y` <ca Y`]b`h`Y`I "G" dfcj]XYX`h`YfY`]g`U`A cV]Y` <ca Y`
 Uddfcj YX` : UMcfm`í`]h` :]FYd`UW`]bghU`YX` k]h` UXYei UH` ZYg` U]f` g`i dd`nā UbX`h`U`h`U`h` : UMcfm`í`]h`
 :]FYd`UW`]g`bchU`h`fYX`VYncbX`h`Y`XUa dYf`cf`Ug` g`Y`ZVY]b[`a cX]UYX`" =b`7UbUXUž` =bgYfh`A cV]Y` <ca Y`
]bghU`Uh]cbg`a i gh`VY`dfY!Uddfcj YX`Vm`h`Y`c`W`]bghU`V]cbg` 5` ZFYfgUbx]b[`]bghU`Uh]cb` fYei]fYa Ybhg`]b`
 Í =bghU`Uh]cb` CZ 5` @ghYXž: UMcfm`í`]h` 7\ ja bYnīž`a i gh`Vt`a d`mk]h` U`c`W` VtXYg`h`U`h`a UmUdd`nā UbX`
 h`Y`Zc`ck`]b[`a i gh`VY`a Yh`

J 9BH-B; .

=b`7UbUXU. `5bml @!G* &-`]ghYX`W]a bYmgngh`a`k`]h` h`Y`UWt`a dUbrn]b[`Xci`VY!k`U`j`Ybh`VtbbYV]cbf`"

=b`I`'G5'" 5bml @%\$` !<H`]ghYX`W]a bYmgngh`a`k`]h` h`Y`UWt`a dUbrn]b[`Xci`VY!k`U`j`Ybh`VtbbYV]cbf`"
 8c`bch`VtbbYVMU`]ghYX`W]a bYmcZ`cbY`a Ubi ZMM fY`k`]h` U`]ghYX`Xci`VY`k`U` VtbbYV]cbf`Zca`Ubch`Yf`
 a Ubi ZMM fY`"

=b g h U ` ` Uh]c b

H\YgY' VtbbYVtcf'g' a i gh VY']bghU`YX']b' UWtfxUbW' k]h' h'Y' a Ubi ZUMi fYf'g']bghfi V]cbg' I gY' cb'mi gdYV]UYX' Vt'a dcbYb'g' H\Y' W]a bYmUbX'd]dY'a i gh YI hYbX'Uh'YUgh%\$'ZYhf&'(' a E'UVcj Y'h\Y'g'hcj Y'UbX' ' 'ZYhf'f\$'- ' a E'UVcj Y'h\Y'\] \Ygh'dc]b'hcZ'h\Y'fccZ' =bghU`'U'fU]b'W'd'k]h' gdUf_ UffYg'hc'f'Uh'h\Y'hc'd'h\U'h' k]' b'ch']a dYXY' h\Y' ga c_Y' YI \Ui gh' H\Y' W]a bYm a i gh VY' gi ddcf'YX'Uh'h\Y'W]]b['cf'fccZ'gc'h\U'h']hg' k Y][\h'k]' b'ch'g]h'cb'h\Y'g'hcj Y' GYU'k]h' g]]Vt'by'hc' a U]b'U]b'] Udcf'VUff]Yf'Uh'h\Y'W]a bYmUbX'ci hg]XY' U]f'dYbYhfU]h'cb'g'

75I H=CB. H<9' GF I 7H F 5@ =BH9; F =M C: H<9' AC6=@9 <CA 9: @CCFž K 5@= 5B8' 79=@B; #FCC: AI GH'69'A5=BH5=B98"

CI HG=89'5=F :

7cbbYV]cb' Z'ca' h\Y' g'hcj Yg' U]f']b'U]_Y' hc' h\Y' ci hg]XY']g' a UbXU'hc'f'm' f'AC6=@9 <CA 9G' CB@M' Y]h\Y'f' h'f'ci [\ U' \c'Y']b' h\Y' k U' b'ch'] \Yf' h\U'b' h\Y' g'hcj Yg' V'hc'ca' 'cf' h'f'ci [\ U' \c'Y']b' h\Y' U'ccf' VYbYU'h' h\Y' dYXY'g'U'z' i g]b['h\Y' Z'Y'g' U]f' UXUd'hc'f' d'fcj]XYX'" =Z'h\Y' U]f']b'U]_Y']g' h'f'ci [\ h\Y' U'ccf'z' h\Y' \c'Y']b' h\Y' dYXY'g'U' VUW' a i gh VY' Vt'cgYX' k]h' h\Y' g\Y'Y'ha Y'U' Vt'j Yf' d'fcj]XYX'" 5j c]X'W'h]b['U'om'U'ccf' 'c]g'g'z' k U' gh X'g'z' Y'Y'V'f]W' k]f]b['cf' d'i a V]b[" GYU' U'f'ci bX' h\Y' ci hg]XY' U]f' d]dY' k]h']b'g']U'h'cb' hc' d'fY']b'hi X'f'U'z'g'" 5'gc']b'ghU`' U' I' a Yg' \fcXY'b'hc'f' dYgh'g'V'Y'Y'b']b' h\Y' Y'bX' cZ' Z'Y'g'U'!U]f' d]dY'" : fY'g'U'!U]f' Vt'bbYV]cb'a i gh VY' cZ'U'bc'b!Vt'a Vi gh]VY'a U'hYf'U'z' YI Ua d'Y' . (I' f'p'\$%'%&' Vt' E'UYI]VY' U'i a]bi a' g]b['Y' k U' d]dY'"

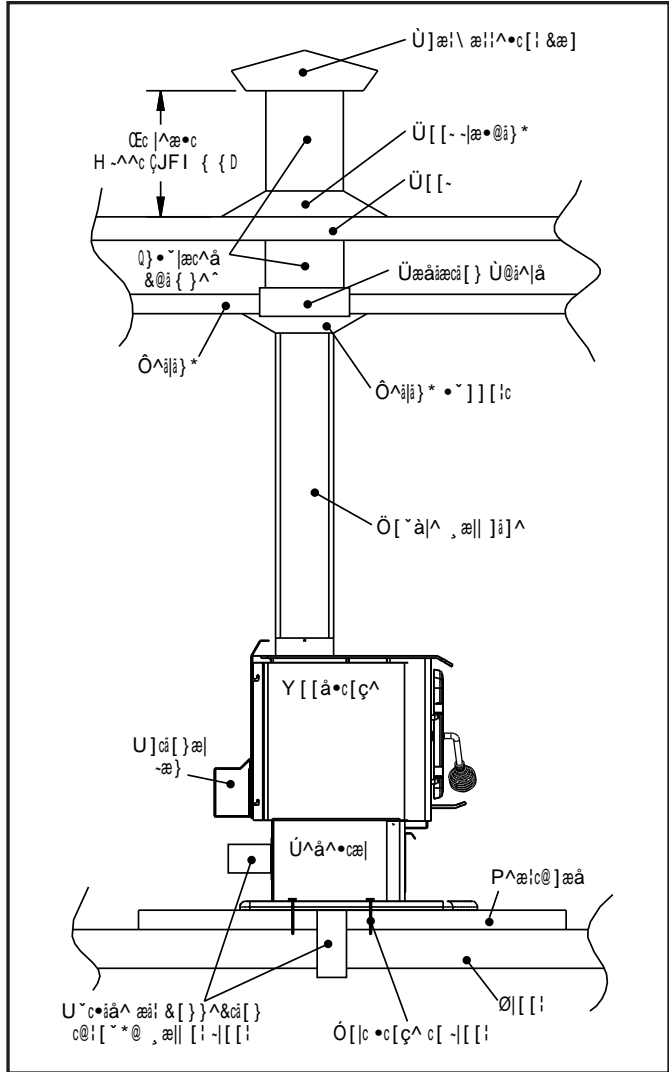

: fY'g' U]f' Vt'i 'X' U'gc' VY' gi dd']YX' Z'ca' U'j Y'b'hYX' :] [i fY' * . : fY'Y'gh'UbX]b[]b'ghU`U'h]cb]b'hc'a cV]Y\ca Y'" V]U'k `gdUW'"

H\Y' dYXY'g'U' a i gh VY' U'fa 'mVc'hYX'hc' h\Y' U'ccf' i g]b['h'c'f'f&E' I' Vc'hg'" 6Y'gi fY'hc' fY'd'UW' U'bm]b'g']U'h'cb' cf'dUbY'g'fYa cj YX'k \Yb'Z'gh'Y'b]b['h\Y' V'hc'ca' 'bi'hg'"

=Z'fcca' U]f' gh]U]f' U'h]cb' c'W'f'g' VY'W'i gY' h\Y' U]f']b'U]_Y']g' V'c'W'YX' k]h']W'z' YUj Yg' Y'W'cf' VY'W'i gY' h\Y' g'hcj Y' X'ccf' k Ug' Y'Z'ic'dYb'z'cf' Xi Y'hc' U'g'f'cb['YI \Ui gh'Z'ub'cdYf'U'h]b[ž'XUb[Y'fci g'Z' a Yg'Vt'i 'X'VY'gi W'YX']b'hc'h\Y' fcca "

=B'GCA 9'5F 95G' =H'A 5M69'F 9E I =F 98'HC 9@97HF =75@4M; FCI B8'H<9'GHCJ 9'HC'H<9'GH99@7<5GG=G' C: H<9'AC6=@9 <CA 9'

K \Yb'h']g' i b]h']g']b'ghU`YX']b'U'AcV]Y' <ca Y']h'ia i gh VY' [fci bXYX'hc' h\Y' gh'Y' W'U'gg]g'cf' Vt'bbYV]W'X'hc' U' [fci bX]b['fcX'"

A Ubi ZUMi fYX'f'AcV]Y'f'ca Y']b'ghU`U'h]cb'a i gh VY']b' UWtfxUbW' k]h' h\Y' A Ubi ZUMi fYX' <ca Y' 7c'bg'f'i V]cb' UbX' GUZY'm'G'U'X'U'f'X'z' i @' \$+6ž H]h'Y' &' ('7: Fž DUfh' & , \$' UbX' #cf' h\Y' G'U'ubX'U'f'X' Z'cf' A Ubi ZUMi fYX' <ca Y' =b'ghU`U'h]cb'gž 5BG'=5&&) "%#B: D5') \$%5"

K 5FB=B; . 8C' B'CH' =BGH5@@ =B 5' A C6=@9 <CA 9'G@99D=B; 'FCCA"

=b g h U ` ` U h] c b

A 5GCBFM: =F 9D@579` =BGH5@5H=CB !` =BG9FH.

I b`Ygg'nci `UFY`YI dYf]YbWXžk Y`fYVta a YbX`]bghU`Uh]cb Vmnci f`XYUYf`cf`U`
dfcZYgg]cbU`]bghU`Yf"

=h`jg`fYVta a YbXYX`h`Uh`nci`]bghU` `h`Y`XYVt`f`U`h`j`Y`d`U`h`g`f`I`Z`di`f`W`U`g`Y`X`E`]`b`h`c`h`Y`g`f`c`i`X`g`
VYZfY`]bghU`]b[`h`Y`i`b`]h`F`Y`Z`f`h`c`I` =BGH5@5H=CB`C: `8`9`7`C`F`5`H`J`9`D`@`5`H`9`G`!` =BG9FH`I`"

=bghU` `cb`m]b`U`a` Ugcbfm`UFYd`UW`k`]h`U` [ccX!`Vt`bX]h]cb`W]a` bYmUh`YUgh`%` Zh`f`("`a`E`\\`][`\\`ž`V`ch`c`Z`
k`\\`W`\\`U`j`Y`VY`b`Vt`bghf`i`W`Y`X`]b`UW`t`f`X`U`b`W`k`]h`h`Y`Vi`]X]b[`Vt`XY`"F`Y`Z`f`h`c`H`U`V`Y`g`)` UbX` ,` Z`c`f`a`]b`j`a` i` a`
a` Ugcbfm`UFYd`UW`X]a` Ybg]cbg`"6Y`g`i` f`Y`h`Y`UFYd`UW`UbX`W]a` bYmUFY`W`U`b`UbX`g`c`i`b`X`k`]h`c`i`h`U`b`m`V`U`W`g`
cf`cc`g`Y`a` cf`h`U`"8`c`b`ch`f`Y`a` c`j`Y`U`b`m`V`f`]W`g`c`f`a` cf`h`U`f`Z`f`c`a` h`Y`UFYd`UW`"

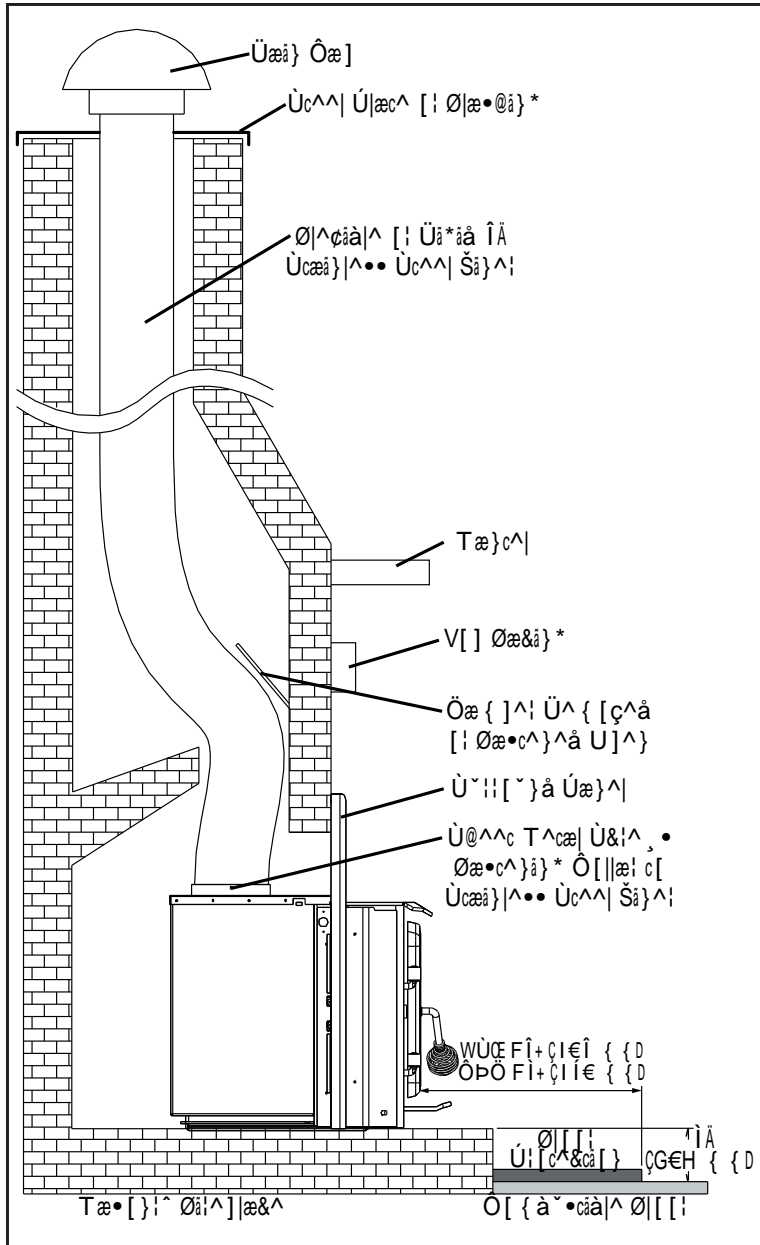

:] [i fY` +. =bgYfh=bghU`Uh]cb]bhc`YI`]gh]b[`UFYd`UW`k`]h`
\\YUfh`"

=Zh`YfY`]g`U`Vt`a` Vi` gh]VY`Üccf`]b`Z`f`c`b`h`c`Z`h`Y`
a` Ugcbfm`UFYd`UW`ž`h`Y`UFYd`UW`]bgyf`h`i` a` gh`
VY` ,` I` f`B`\$` `a` a` E` U`V`c`j`Y` h`Y` Vt`a` Vi` gh]VY`
Üccf`UbX`Üccf`df`ch`V`W]cb`a` i` gh`VY`df`c`j`]XYX`
%` I` f` () +`a` a` E`]b`Z`f`c`b`h`c`Z`h`Y`UFYd`UW`]bgyf`h`
UbX` ,` I` f`B`\$` `a` a` E` h`c`Y`U`W` g]XY`c`Z`h`Y`i`b`]h`
F`Y`Z`f`U`g`c`h`c` G`D`9`7` =75H=CBG`!` 7`@`9`5`F`5`B`7`9`G` H`
7`C`A`6`I` G`H`-6`@`9`G`!` %`&`\$`\$` =BG9FH` UbX` G`D`9`7` =75H=CBG`
!` 7`@`9`5`F`5`B`7`9`G` H` 7`C`A`6`I` G`H`-6`@`9`G`!` %`+`\$`\$` =BG9FH`"

%` F`Y`a` c`j`Y`U`b`m`UFYd`UW`X`U`a` d`Y`f`c`f`Z`j`g`h`Y`b`
]b`U`d`Y`f`a` UbY`b`h`c`d`Y`b`d`c`g]h]cb`"

&"`f`H`7`5`B`5`8`5`E`h`Y`g`r`c`j`Y`]g`j`Y`b`h`Y`X`k`]h`
U`*`I` gh]b`Y`gg`gh`Y`"]bYf`h`Uh[c`Y`g`X]f`Y`V`m`h`c`
h`Y`h`c`d`c`Z`h`Y`W]a` bYm`UbX`]g`Vt`j`Y`f`Y`X`k`]h`
U`f`U]b`W`d`" h`Y`W]a` bYm`h`c`d`]g`g`Y`U`Y`X`k`]h`
U`U`U`g`]b[`c`f` gh`Y`d`U`h`Y`h`Uh`g`i`d`d`c`f`r`g`h`Y`
k`Y][`h`c`Z`h`Y`W]a` bYm`]b`Y`f`h`Y`]bghU`Uh]cb`
a` i` gh`Vt`b`Z`c`f`a` h`c`h`Y`]b`Y`f`g` a` U`b`i`Z`U`h` f`Y`f`g`
]bghf`i`W]cbg`"

H`]g`UFYd`UW` a` i` gh` VY`]bghU`Y`X`k`]h`U`
Vt`b`h]b`i`c`i`g`]b`Y`f`c`Z`*`I`X]U`a`Y`h`f`f`7`5`B`5`8`5`
C`B`@`M`E`Y`I`h`r`b`X]b[`Z`f`c`a` h`Y`UFYd`UW`]bgyf`h`c`
h`Y`h`c`d`c`Z`h`Y`W]a` bYm`h`Y`W]a` bYm`]b`Y`f`
a` i` gh`Vt`b`Z`c`f`a` h`c`h`Y`W`U`g`g`" f`Y`e`i`]f`Y`a`Y`b`h`g`c`Z`
I` @!`G`*`)` G`H`U`b`X`U`F`X`Z`c`f` @]b]b[`G`n`g`h`Y`a`g`Z`c`f`
9`I`]g`h]b[`A` Ugcbfm`c`f` :`U`W`c`f`n`h`6`i`]h`7`^`]a` b`Y`n`g`
UbX`J`Y`b`h`g`ž`c`f`I` @!`G`*` (\$`G`H`U`b`X`U`F`X`Z`c`f` @]b]b[`
G`n`g`h`Y`a`g`Z`c`f`B`Y`k` `A` Ugcbfm`7`^`]a` b`Y`n`g`"

f`H`I`'G`5`E`h`Y`U`d`d`]U`b`W`k` \\Y`b`]bghU`Y`X`ž`
a` i` gh` Z`c`k` `c`W` Vi`]X]b[`Vt`XY`g`ž`]b` h`Y`
U`V`g`Y`b`W`c`Z`c`W` Vi`]X]b[`Vt`XY`g`ž`k`]h` h`Y`
W`f`f`Y`b`h`B: `D`5` &`%` G`H`U`b`X`U`F`X`Z`c`f` 7`^`]a` b`Y`n`g`ž`
:]f`Yd`UW`g`ž` J`Y`b`h`g`ž` UbX` G`c`X` :`i`Y`!`6`i`f`b]b[`
5`d`d`]U`b`W`g`"

=bghU` Uh]c b

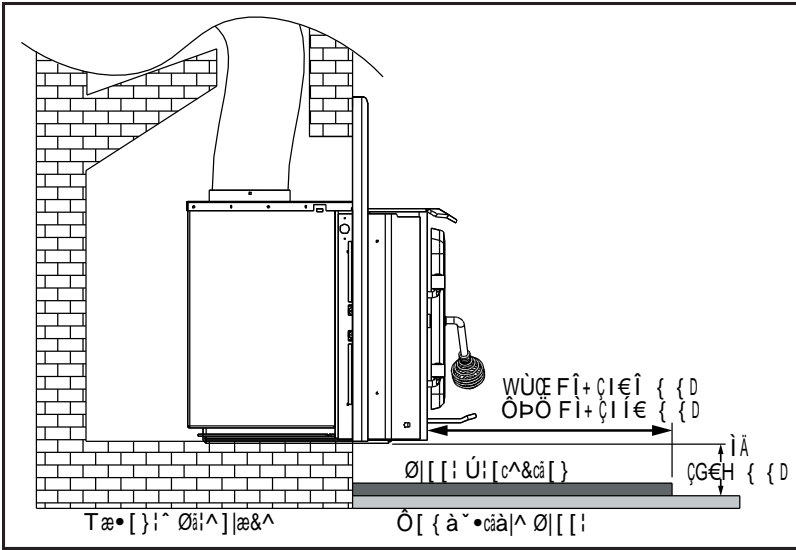

:]i fY" , . =bgYfh=bgU`Uh]cb]brc Yi]gh]b['ÜFYd'UW'k]h ci h \YUfh"

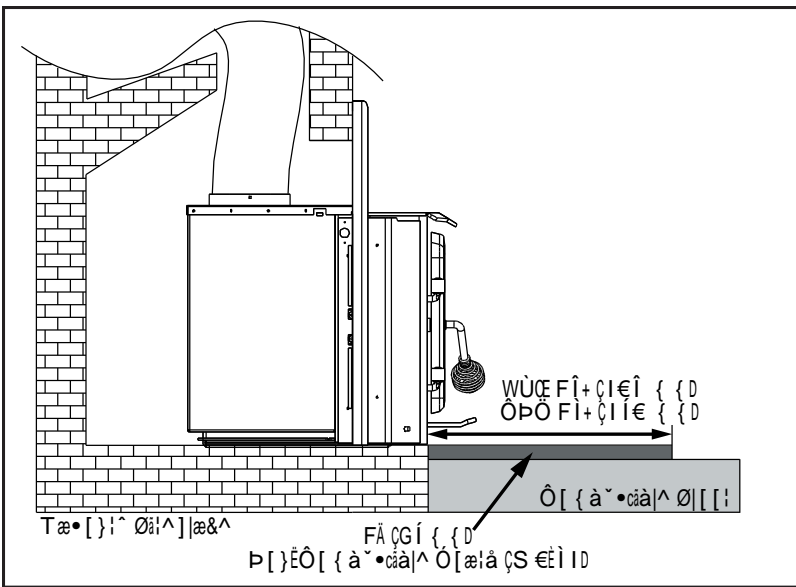

:]i fY" - . =bgYfh=bgU`Uh]cb]brc Yi]gh]b['Üccf`Yj Y`a Ugcbfm ÜFYd'UW"

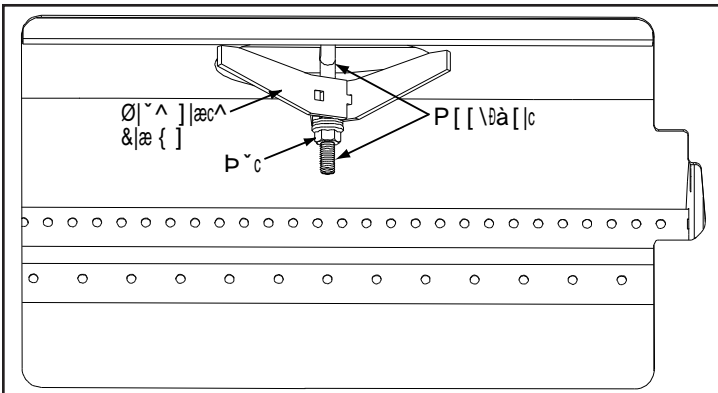

:]i fY" (\$. 5HUW]b['fYa cj UVY'Üi Y"

HAY' Üi Y' Vè`UF']g' fYa cj UVY' Zcf']bghU`Uh]cbg']brc' ÜFYd'UW'g' k]h' `ck' cdYb]b[g"

U: fYa cj Y' hAY' Üfghi k c' f&L' Zcbhi gYVèbXUfm Ujf' hi VY' UbX' WfUa]W VUZjYg']Z]bghU`YX' fbYY' 79F5A=7' 65: : @' =BGH5@5H-CBÉ"

V: I bgWYk' hAY' bi h cb' hcd' cZ hAY']bg]XY' cZ hAY' ÜFYVcl ži g]b['U' -#%Î' k fYbW' cf' gcWYhfbYY' :]i fY' (\$L' hAY' Üi Y' d'UHY' WUa d' k]`g]XY' cZ hAY' \cc_#WUa d"

W: Di ` hAY' \cc_#Vc'h UbX' hAY' fYa cj UVY' Üi Y' Vè`UF' cZ hAY' hcd' cZ hAY' i b]h'

X: 5HUW hAY' Üi Y' Vè`UF' hAY' j Ybh]b[' d]dY' i g]b[' g\YYha YHU' gWYk' g"

Y: Di g\ hAY' i b]h']brc' d'UW' k \]Y' hfn]b[' h' _Yd' hAY' Vè`UF' UHUWYX' h' j Ybh]b[' Vègy' h' hAY' cdYb]b[' cb' hAY' hcd' cZ hAY' i b]h'

Z: I g]b[' hAY' \cc_#Vc'hž [fUV' hAY' Üi Y' Vè`UF' VmihAY' fcX' h' fci [\ hAY' WbhYf' UbX' di `]h']brc' d'UW' fgYY' :]i fY' (%L"

[: G]XY' hAY' Üi Y' d'UHY' WUa d' cj Yf' hAY' YbX' cZ hAY' \cc_#Vc'h UbX' gWYk' hAY' bi h' VUW' cb' h' hAY' \cc_#Vc'h'

\: FY!]bghU` WfUa]W VUZjYg' UbX' hAY' Üfghi k c' f&L' Zcbhi gYVèbXUfm Ujf' hi VY' fbYY' 79F5A=7' 65: : @' =BGH5@5H-CBÉ"

' "HAYfY'ÜFY'k c' f&L'`Yj Y]b[`Y[g'fg\ck b']b':]i fY' (&L' cbY' cb' YUW' g]XYž' Uh' hAY' VUW' cZ hAY' i b]h' 5X† gh' hAY' Y[g' i g]b['U' -#%Î' k fYbW' h' Ybg' fY' hAY' i b]h' g'gUVY"

(' "GWYk' cf' bU]` hAY' a YHU' d'UHY' dfcj]XYX' VmihAY' a Ubi ZUM' fYf' h' hAY']bg]XY' cZ hAY' ÜFYd'UW"

A 9H5@ H5; . ÍH<=G' : =F9D@579' <5G' 699B' 5@49F 98' HC' 577CAAC85H9' 5' : =F9D@579' =BG9FH' 5B8' G<CI @8' 69' =BGD97H98' 6M5' E I 5@= =98' D9F GCB' DF =CF' HC' H<9' F9! I G9' 5G' 5' 7CBJ 9BH-CB5@: =F9D@579†

=bghU` `Uh]c b

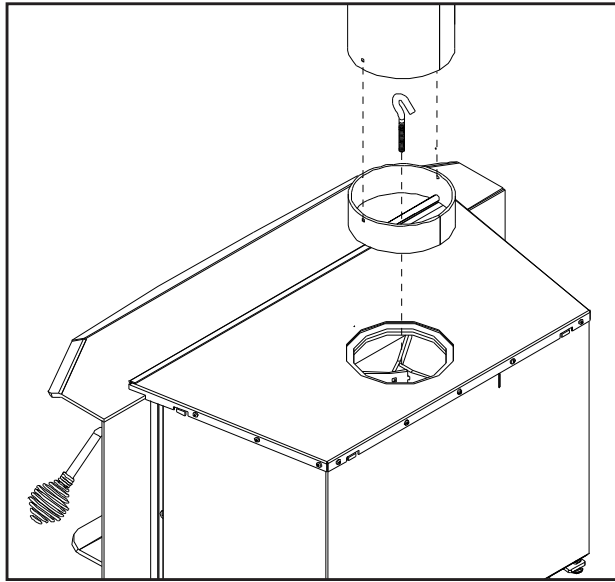

:] [i fY' (% '5HJW]b['fYa cj UVYÚi Y"

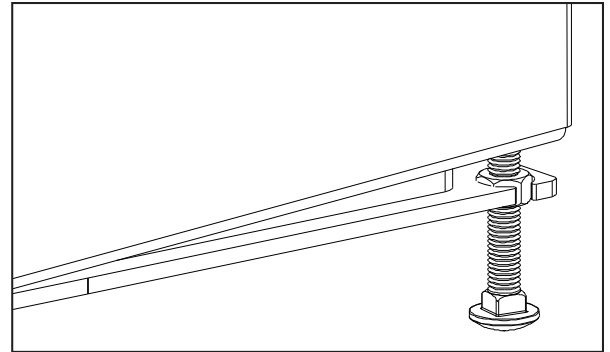

:] [i fY' (& ' @j Y]b["Y["

G FFCI B8 D5B9@G95@98 =BGH5@5H-CB : CF I G5'CB@M! =BG9FH

6YZcfY' gUfh]b[' h]g' maly' cZ]bghU`Uh]cb`
 fYZf' hc' =BGH5@5H-CB' !' A 5GCBFM : =F9D@579`
 =BGH5@5H-CB' !' =BG9FH' Zcf' UXX]h]cbU`
]bZcfa Uh]cb" : cf' VWUfUbWg' fYZf' hc`
 G097 = =75H-CBG' !' 7@95F5B79G' Hc' 7CA6I GH-6@9G`
 !' %&\$\$ =BG9FH' UbX' G097 = =75H-CBG' !' 7@95F5B79G`
 Hc' 7CA6I GH-6@9G' !' %+\$\$ =BG9FH"

%: 6YZcfY' h.Y' ZJW' d'UhY']g']bghU`YX`
 cbhc' h.Y' i b]h' [i Y' U' *I' fP0 \$a a E`
 k]XY' F&\$' UVyf[`Ugg']bgi' Uh]cb' gfd`
 Ufci bX' h.Y' dYf]a YHf' cZ h.Y' VUW' cZ`
 h.Y' dUbY'g' i g]b[' FHJ' g]]Vtb' cf' gncY' Y`
 [Ug_Yh Wa Ybh' K \Yb' h.Y' ZJW' d'UhY`
]g']bghU`YX` cbhc' h.Y' i b]h' h.Y']bgi' Uh]cb`
 a i gh' cj YfUdg' h.Y' Úfyd'UW' cdYb]b[`
 hc' Zcfa' U' gYU' VYk YYb' h.Y' a Ugcbfm`
 Úfyd'UW' UbX' h.Y' i b]h'g' ZJW' d'UhY'" @Yh`
 h.Y' g]]Vtb' cf' Wa Ybh'Xfm"

&" Hc' a U_Y h.Y']bghU`Uh]cb`cZ h.Y' g' ffcI bX`
 dUbY`cbhc' h.Y' i b]h' YUgm\Uj Y' h.Y' i b]h`
 *I' fP0 \$a a E'ci hZca' h.Y' Úfyd'UWZ`

' " Di g\ h.Y']bgyfh']bhc' h.Y' Úfyd'UWZ`
 U'ck]b[' h.Y']bgi' Uh]cb' hc' Zcfa' U' gYU`
 VYk YYb' h.Y' dUbY'g' UbX' h.Y' Úfyd'UW`
 H' W' UbmYI dcyX']bgi' Uh]cb' VY\]bX' h.Y`
 ZJW' d'UhY"

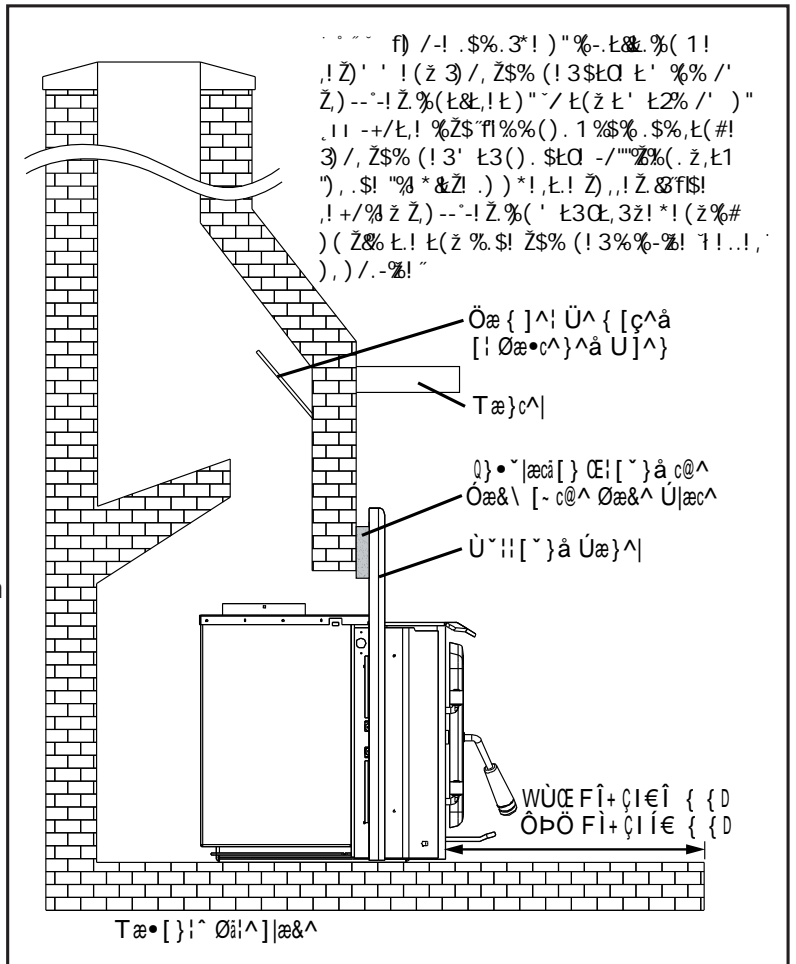

:] [i fY' (' . =bghU`Uh]cb`k]h' G' ffcI bX'GYUYX"

=b g h U ` ` Uh]c b

=BG5@5HCB I G=B; '5'6@c7?!C.: 'D@5H9: cf I G5 CB@vI! '=BG9FH.

=Z h]g i b] h]g' h'c' VY']b g h U' YX']b h'c' U' a' U g c b f m i U f y d' U W' c f' U n y f c! W W U f U b W' U f y d' U W' k] h' U' X] f y V h' V e b b y V W] c b' m e i' a' i' g h']b g h U' U' b c b! V e a' V i' g h] V Y' g Y U! c Z Z' X Y j'] W' g i' W' U g' U' V' c W! c Z Z' d' U H Y' c f' X U a' d Y f' U X U d H Y f' 6 m']b g h U']b[' U' V' c W! c Z Z' d' U H Y' m e i' g Y U' h' Y' W] a' b Y n a' Y b g i' f] b[' h' U h b c' g a' c_ Y' Y b h f g' h' Y' \ c a' Y' U b X' g Y U']b[' h' Y' W] a' b Y m i' c' Y b V e i' f U[Y' X f U Z h' H' c' V e b g h f i' V h' U' V' c W! c Z Z' d' U H Y' Z' c k' h' Y' V Y' c k' g h Y d g'

%: 8 Y H Y f a']b y' k' \ Y f Y' h' Y' V' c W! c Z Z' d' U H Y' k']' V Y']b g h U' Y X' / U W c j' Y' h' Y' h c d' c Z h' Y' U f y V c l' f] h' a' i' g h' V Y' \[\ Y b c i' [\ h' c' Y U g] m']b g h U' h' Y' V e b b y V W] c b' d] d Y e' V i' h' V Y' c k' h' Y' X U a' d Y f' U f Y U' @ c c_ Z c f' U' c W h] c b' h' U h']g' Y j' Y' U b X']b' U b' U f Y U' k' \ Y f Y' h' Y' d' U H Y' W b' V Y' a' c i' b H Y' X' Y U g] m'

· H Y' a' Y U g i' f Y a' Y b h' h' U h' k']' V Y' b Y Y X Y X' U f Y' U g i' Z' c k' Y X' f f Y Z f' h' c' :] i' f Y' ((' U b X')) e

5! ' H Y' k'] X h' U h' h' Y' Z f c b h c Z h' Y' U f y V c l' U h' h' Y' \ Y] [\ h k' \ Y f Y' h' Y' V' c W! c Z Z' d' U H Y' k']' V Y']b g h U' Y X'

6! ' H Y' k'] X h' U h' h' Y' V U W' c Z h' Y' U f y V c l' U h' h' Y' \ Y] [\ h k' \ Y f Y' h' Y' V' c W! c Z Z' d' U H Y' k']' V Y']b g h U' Y X'

7! ' H Y' b' X Y d h' c Z' h' Y' V' c W! c Z Z' b Y Y X Y X' f h' Y' X] g h U b W' V Y h' Y b' 5' U b X' 6 e'

8! ' H Y' X] g h U b W' c Z h' Y' W b h Y f' c Z h' Y' U i' Y' h' c' h' Y' Z f c b h c Z h' Y' U f y d' U W' c d Y b] b[" F Y Z f' h' c' G h Y d' "

· **BCH9** = b [Y b y f U' a' U g c b f m i U f y d' U W' g' \ U j' Y' g e i' U f Y' U f y V c l' Y g' k' \] Y' n y f c! W W U f U b W' f a' Y H U e' U f y d' U W' g' \ U j' Y' X c a' Y X' U f y V c l' h' c d g' h' Y' Y f Y Z c f Y' n y f c! W W U f U b W' V' c W! c Z Z' d' U H Y' g a' U m V Y' a' c f Y' X] Z W' h' h' c']b g h U' = b g i' U h] c b' a' U m V Y' i' g Y X' U f c i' b X' h' Y' Y X' [Y g' h' c' g] a' d'] Z h g Y U']b[' h' Y' d' U H Y'

&: 7 f Y U H Y' U' W W f X V c U F X' h' Y a' d' U H Y' c Z h' Y' X] a' Y b g] c b g' k'] h' & i' f] % V e i' k'] X Y' U b b [Y g' c b' Y U W' g] X Y' h' Y' g Y' U b b [Y g' k']' V Y' i' g Y X' h' c' a' c i' b h' h' Y' V' c W! c Z Z' d' U H Y' h' c' h' Y']b g] X Y' c Z h' Y' U f y V c l' " 6 Y b X' h' Y' U b b [Y g' X c k' b k' U f X g' c b' h' Y' h' Y a' d' U H Y' U b X' d' U W'] h']b g] X Y' h' Y' U f y d' U W' " 7 c b h] b i' Y' c b'] Z' h' Y' h' Y a' d' U H Y' U h g' V e f f Y V h' m']b'] h g' d' U b b Y X' c W h] c b' = Z' h' Y' h' Y a' d' U H Y' X c Y g' b c h' U h' z' a' U_ Y' U' b Y k' h' Y a' d' U H Y' k'] h' h' Y' f Y e i'] f Y X' V e f f Y V h] c b g' i' b h]] h' X c Y g' U h' V e f f Y V h' m'

' " K] h' h' Y' h' Y a' d' U H Y']b' d' U W' z' a' U f_ h' Y' c W h] c b' Z c f' h' Y' W b h Y f' c Z h' Y' U i' Y' d] d Y k' \ Y b' h' Y' i' b] h] g']b' d' U W' = Z]b g h U']b[' U' % & \$ \$' h' Y' X] g h U b W' k']' V Y' U d d f c l'] a' U h Y' m' i' c f' - % # % i' V U W' Z f c a' h' Y' U f y d' U W' c d Y b] b[" = Z]b g h U']b[' U' % + \$ \$' h' Y' X] g h U b W' k']' V Y' U d d f c l'] a' U h Y' m' % & i' c f' % ^ + # % i' V U W' Z f c a' h' Y' U f y d' U W' c d Y b] b[" F Y a' c j' Y' h' Y' h' Y a' d' U H Y' U b X' W h U' * i' X] U a' Y h Y f' \ c' Y' W b h Y f Y X' c b' h'] g' a' U f_ "

(" I g] b[' h' Y' h' Y a' d' U H Y' a' U_ Y' h' Y' V' c W! c Z Z' d' U H Y' c Z & ([U i' [Y' c f' h'] W Y f' g h Y' " 8 f] h' c' f & e' \ c' Y g']b' Y U W' U b b [Y' Z c f' a' c i' b h] b[' h' Y' d' U H Y'

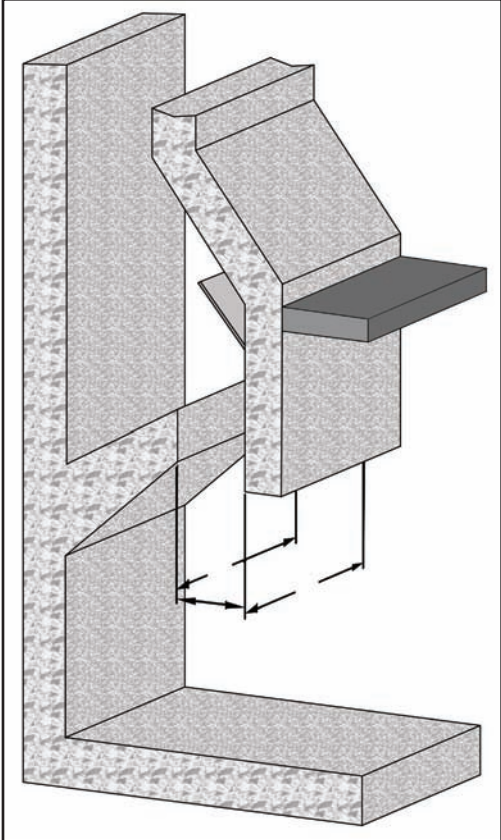

:] i' f Y' ((' 8' c Z 8] a' Y b g] c b g' b Y Y X Y X' Z f c a' h' Y' :] f y d' U W'

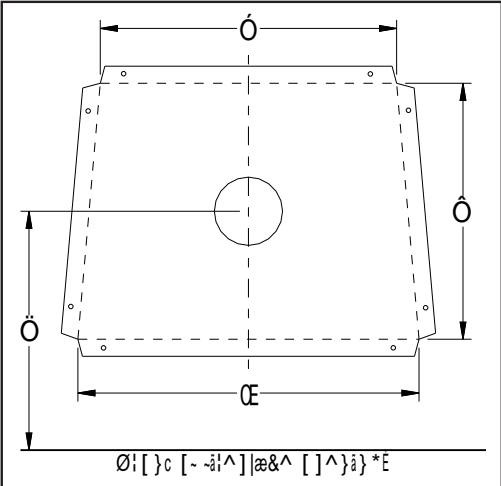

:] i' f Y' () . @ U h c i' h c Z h' Y' 6' c W! c Z Z' d' U H Y'

=bghU` `Uh]c b

A C89@%&\$\$'6F=7? 'D@579A 9BH/ 'H 69'@C75H-CBG.

7CAD@9H9'H<9'GHCJ 9'5B8 'GAC?9'D=D9'=BGH5@5H-CB'69. CF 9'D@57=B; 'H< 9G9'6F=7?G'

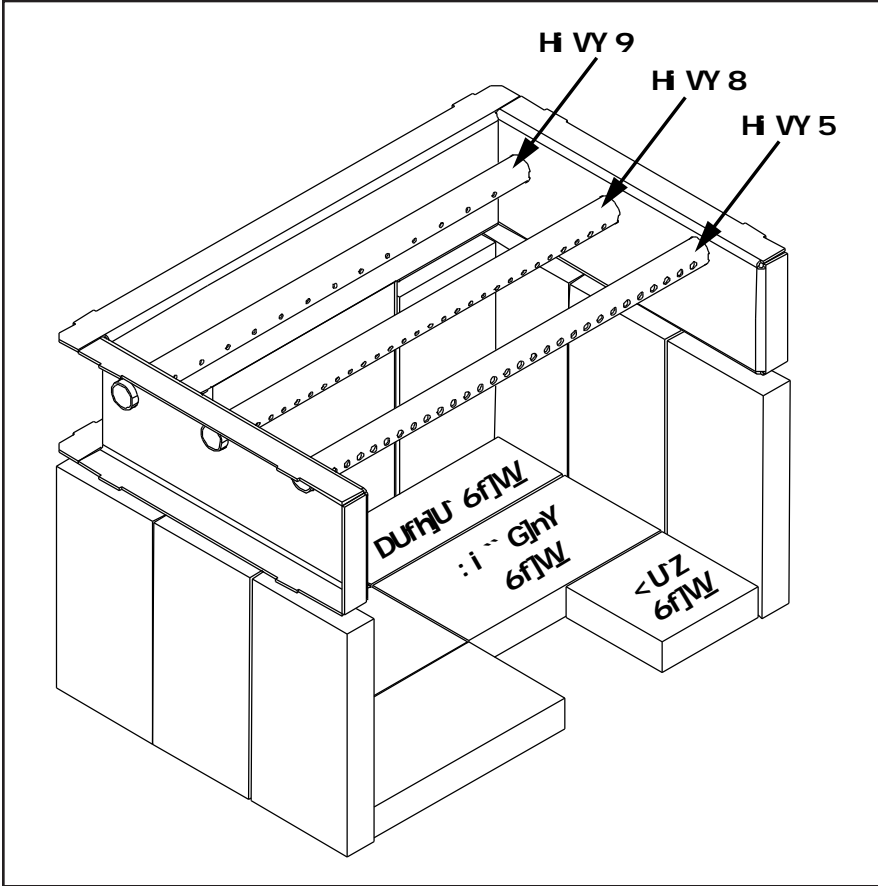

%" D'UW' h.Y' h.fyy' fl' z' z' g]nY' Vf]Wg' Ucb['YUW' g]XY' cZ h.Y' UfYVcl' UbX' cbY' f%&' z' g]nY' Vf]W' cb Y]h.Yf'g]XY' cZ h.Y' VUW' cZ h.Y' UfYVcl' "

&" Hc' d'UW' h.Y' Uccf' Vf]Wg'z' Um' h.Y' tk' c' f&L' dUfh]U' Vf]Wg' Ucb[' h.Y' VUW' cZ h.Y' Uccf' h.Y' b' cb' h.Y' YZz' Um' tk' c' f&L' z' g]nY' Vf]Wg' UbX' cb' h.Y' f] [\h'z' Um' U' z' g]nY' Vf]W']b' h.Y' Wbhf' UbX' h.Y' \Uz Vf]W']b' h.Y' Zcbh' fZcf' h.Y' Ug\ ' Xi a dL' h.Y' gdUWg' VYtk' YYb' h.Y' Vf]Wg' k]' gccb' U' k]h' Ug\ Yg'

:] [i fY' (, . '6f]W' D'UW' a YbhZcf' %&\$\$' g'ck b'k]h' G'W'zbXUfm]f' 7\ UbbY' UbX' H' VYg'

K \ Yb' fYd'UM]b['Vf]Wg'z' i gY' cb' mdi a Ug'hdY' UfY' Vf]Wg'

HCH5@6F=7?G

%&! : i ~ g]nY' Vf]Wg' - I' cb[' I' (") I' k]XY' I' %&) I' h.]W' f&&' - 'Vd' 'cb[' I' %&' ('Vd' 'k]XY' I' " &' Vd' 'h.]W' L

&! DUFHU' Vf]Wg' ' ' ' - I' cb[' I' ' I' k]XY' I' %&) I' h.]W' f&&' - 'Vd' 'cb[' I' '+' * 'Vd' 'k]XY' I' " &' Vd' 'h.]W' L

%! <UZ Vf]W' (") I' cb[' I' (") I' k]XY' I' %&) I' h.]W' f%&' ('Vd' 'cb[' I' %&' ('Vd' 'k]XY' I' " %+) 'Vd' 'h.]W' L

FYa cj]b['5]f H' VY. =ZU'gY'W'zbXUfm]f' hi VY' bYYXg'hc' VY' fYa' cj YXz' d'UW' U'g'WYk' Xf]j' Yf' fUbm]gmY' Yl' Wdhi' UUh' \YUXL']brc' cbY' cZ h.Y' U]f' \c' Yg' UbX' 'Ud']hk']h' U' \Ua' a' Yf# a' U' Yh'hc' h.Y' YZhi' bh] 'h.Y' f] [\h' YbX' cZ h.Y' hi VY']g' Z'fYX' " Hc']bghU' Uh]cb' U'gY'W'zbXUfm]f' hi VY' fYg' YfgY' h.Y' UVcj' Y']bghf' V]cbg'

=A DCF H5BH' 5' gY'W'zbXUfm]f' hi VYg' a' i' gh' VY']b' d'UW' Zcf' dfcdYf' cdYfU]h]cb'

=bghU` `Uh]c b

A C89@%+\$\$6F=7? D@579A9BH/ H 69@C75H-CBG.

7CAD@9H9Hk9'GHCJ9'5B8'GAC?9'D=D9=-BGH5@@5H-CB'69. CF9'D@57=B; Hk9G9'6F=7?G'

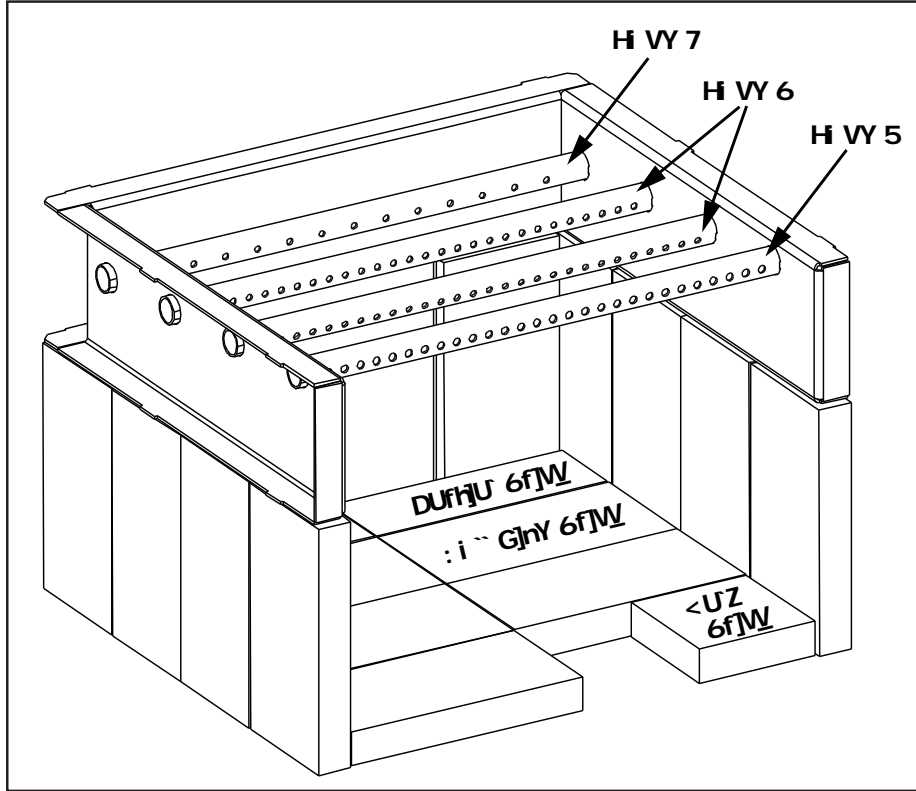

%"DUW hY' zci f' f(E' z' ~ glnY' Vf]Wg' Ucb[' YUW' g]XY' cZ hY' UfYVcl' UbX' cbY' fP& z' ~ glnY' Vf]W' cb' Y]hYf' g]XY' cZ hY' VUW' cZ hY' UfYVcl' "

&"Hc' d'UW hY' Uccf' Vf]Wg'z' Um hY' k c' f&E' dUfh]U' Vf]Wg' Ucb[' hY' VUW' cZ hY' Uccf' H\Yb' cb' hY' YZz' Um hY' fY' f' E' z' ~ glnY' Vf]Wg' UbX' cb' hY' f] [\h'z' Um hY' c' f&E' z' ~ glnY' Vf]Wg']b' hY' WbhYf' UbX' hY' \UZ Vf]W']b' hY' Zcbh' fZcf' hY' Ug' \ Xi a dE' hY' gdUWg' VYk Yyb' hY' Vf]Wg' k]' gccb' U' k]h' Ug' Yg'

:] [i fY' (- . 6f]W' D'UWa YbhZcf' %+\$\$' g\ck b' k]h' G'VtBxUfm]f' 7\ UbbY' UbX' H' Vyg'

K \Yb' fYd' UM]b[' Vf]Wg'z' i gY' cb' mdi a Ug' hndY' UfY' Vf]Wg'

HCH5@6F=7?G

% ! : i ~ glnY' Vf]Wg' - I' ~ cb[' I' (") I' k]XY' I' %&) I' h]W' f&E' - 'Val' ~ cb[' I' %%('Val' k]XY' I' " & 'Val' h]W' E'

& ! 'DUFHJ' Vf]Wg' ~ ~ ~ ~ - I' ~ cb[' I' I' k]XY' I' %&) I' h]W' f&E' - 'Val' ~ cb[' I' + * 'Val' k]XY' I' " & 'Val' h]W' E'

% ! <UZ Vf]W' (") I' ~ cb[' I' (") I' k]XY' I' %&) I' h]W' fP& ('Val' ~ cb[' I' %%('Val' k]XY' I' " %+) 'Val' h]W' E'

FYa cj]b['5]f H WY. =ZU'gYVtBxUfm]f' hi VY' bYXg'hc' VY' fYa' cj YXz' d'UW' U'g'VYk Xf]j' Yf' fUomigmiY' Yl' Wdhi' UUh' \YUXE']b'hc' cbY' cZ hY' Y' U]f' \c' Yg' UbX' hUd']hk]h' U' \Ua' a Yf#a' U' Yh'hc' hY' YZhi' bh] hY' f] [\h' YbX' cZ hY' hi VY']g' ZFYX' " Hc']b'ghU' Uh]cb' U'g'YVtBxUfm]f' hi VY' fYj' YfgY' hY' UVcj' Y']b'g'fi' V]cbg'

=A DCF H5BH' 5' ~ gYVtBxUfm]f' hi VYg' a i ghVY']b' d'UW' zcf' dfcdYf' cdYfUh]cb'

=bghU` `Uh]c b

8CCF` =BGH5@@5H-CB.

D'YUgY`]bgdYVhU` Vta dcbYbhg` Zcf` XLa U[Y" =ZXLa U[Y` \Ug`cWVffYXZ`d`YUgY` VtbhUWh` h`Y` Vti` f]Yf` Vta dUbrñ` XYUYfz` cf` X]gfv]i` hcf` UbX` \Uj` Y` Vta dcbYbhg` fYdU]fYX` cf` fYd`UWX` VYZcfY`]bgH`Uh]cb" FYa` cj` Y` h`Y` Xccf` Zfca` h`Y` dUW`U[]b[" =bgdYVhU` h`Y` Xccf` UggYa` Vm`Zcf` XLa U[Y"

%` =bgH` Xccf` \UbX`Y` Ug`g\ck` b`]b` :] [i fY) \$"

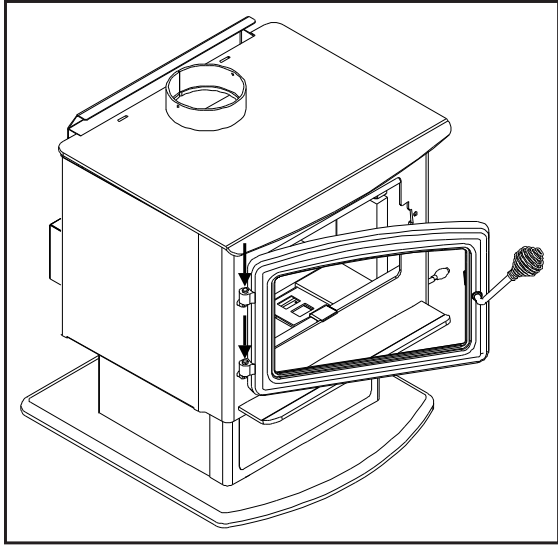

:] [i fY) %` =bgH` Uh]cb` 8ccf` cbrt` l` b]h`

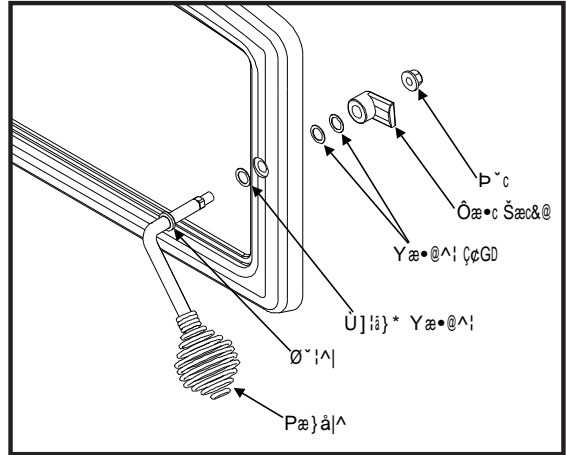

:] [i fY) \$` =bgH` Uh]cb` 8ccf` <UbX`Y` <UfXk` UfY"

&" D'UW` h`Y` Xccf` UggYa` Vm` cb` h`Y` h`c` f&E` \]b[Y` d]bg` a` ci` bhYX` cb` h`Y` VcXmcZ` h`Y` i` b]h` FYZf` h`c` :] [i fY) %"

' " CdYb` UbX` Wcgy` h`Y` Xccfz` Udd`n]b[` dFYggj` fY` Xck` bZ` h`c` Ybgi` fY` h`Y` Xccf` UggYa` Vm`]g` dfcdYf` m` gYUHYX` cb` h`Y` \]b[Yg` FYZf` h`c` :] [i fY` (- "

(" D'YUgY` WUub` U` Üb[Yfdf]bhg` cZZ` cZ` U` d`UhYX` g] fZUWgZ` k`]h` XYbUhi` fYX` U`Vt`c` `cb` U`gcZ`h`Vt`h`Z`VYZcfY` Üf]b[` h`Y` i` b]h` YUW` h`ja` Y" :]b[Yfdf]bhgZ` YhVZ` WUb` VYVta` Y` dYfa` UbYbhim` YhVYX`]brt` h`Y` d`Uh]b[`]Z` bch` fYa` cj` YX` VYZcfY` cdYfU]b[` h`Y` gtcj` Y"

BCH9. K` \Yb` h`Y` Xccf`]g`]bgH`YX` cb` h`Y` i` b]h` UbX` h`Y` \UbX`Y` WcgyXZ` Ybgi` fY` h`Uhi` h`Y` gdf]b[` \UbX`Y`]g` Uhi` h`Y` (.\$`dcg]h]cb"

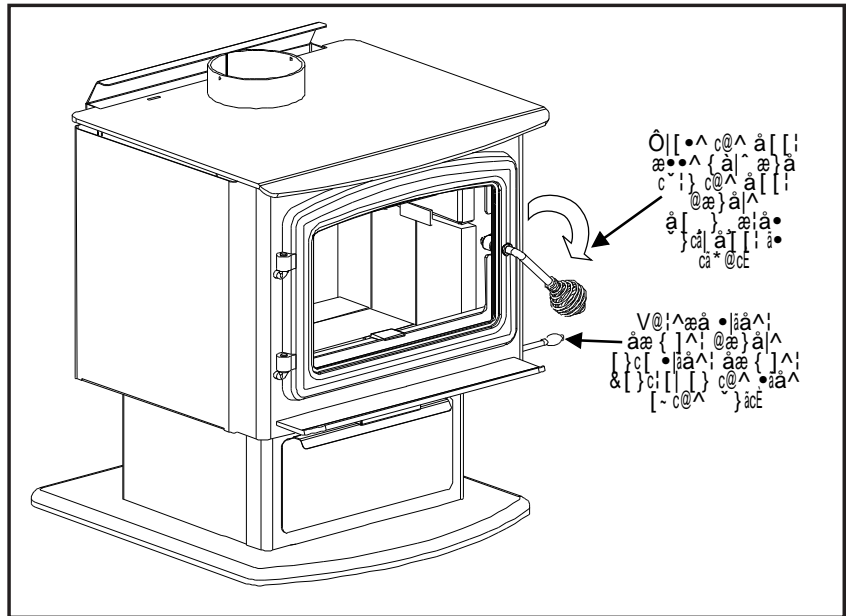

:] [i fY) &` 7`cg]b[`8ccf"

8C`BCH1` G9`8CCF` =` ;` @5GG` =G`6F`C`?`9B"

=bghU` `Uh]c b

79F5A=7'65: :@9`=BGH5@5H=CB.

%` FYa cj Y` HAY` ZfcbhgVvzbXUfmUJf` hi VY` Vmd`UM]b[`U` gMYk Xfj] Yf` fUbmghmY` Yl Wdh UUh` \YUXE`]bhc` cbY` cZ` HAY` UJf` \c` Yg` UbX` HUdd]b[`]hk`]h` U` \Ua` a` Yf#a` U` Yh` hc` HAY` `YZh` GH'd` %]g` cb` mfYei`]fYX` cb` HAY`]bgYfi` a` cXY`g`"

&` G]XY` HAY` f][\h` WfUa`]WVUZJY`]b` cj Yf` HAY` gVvzbXUfmUJf` hi VYg` Uh` HAY` hcd` cZ` HAY` UfYVcl` "HAY` HU` a` i` gh` VY` cb` HAY` hcd` UbX` dc]bh]b[` hck` UfXg` HAY` WbhYf` UbX` HAY` ga` cch` g]XY`]g` hc` ZUW` Xck` b`"

'` <cc` _` HAY` ci` hg]XY` YX[Y` cZ` HAY` VUZJY` cj Yf` HAY` hcd` cZ` HAY` gVvzbXUfmUJf` WUa` VYf` H]g` k`]` a` U` _` fcca` hc` Zcf` HAY`]bghU` Uh]cb` cZ` HAY` `YZh` WfUa`]WVUZJY`"

("` G]XY` HAY` `YZh` WfUa`]WVUZJY`]b` cj Yf` HAY` gVvzbXUfmUJf` hi VYg` HAY` HU` a` i` gh` VY` cb` HAY` Vch` ca` UbX` dc]bh]b[` hck` UfXg` HAY` WbhYf` UbX` HAY` ga` cch` g]XY`]g` hc` ZUW` Xck` b`"

)` "Di` " HAY` VUZJYg` hc[YH` Yf`]b` HAY` a`]X` Y` gc` HAY` f][\h` HU` fYg` g` cb` hcd` cZ` HAY` `YZh` HU` "9bgj` fY` HAY` VUZJYg` UfY` Ui` g` k`]h` HAY` VUW` UbX` Vch` g]XYg` cZ` HAY` UfYVcl` "

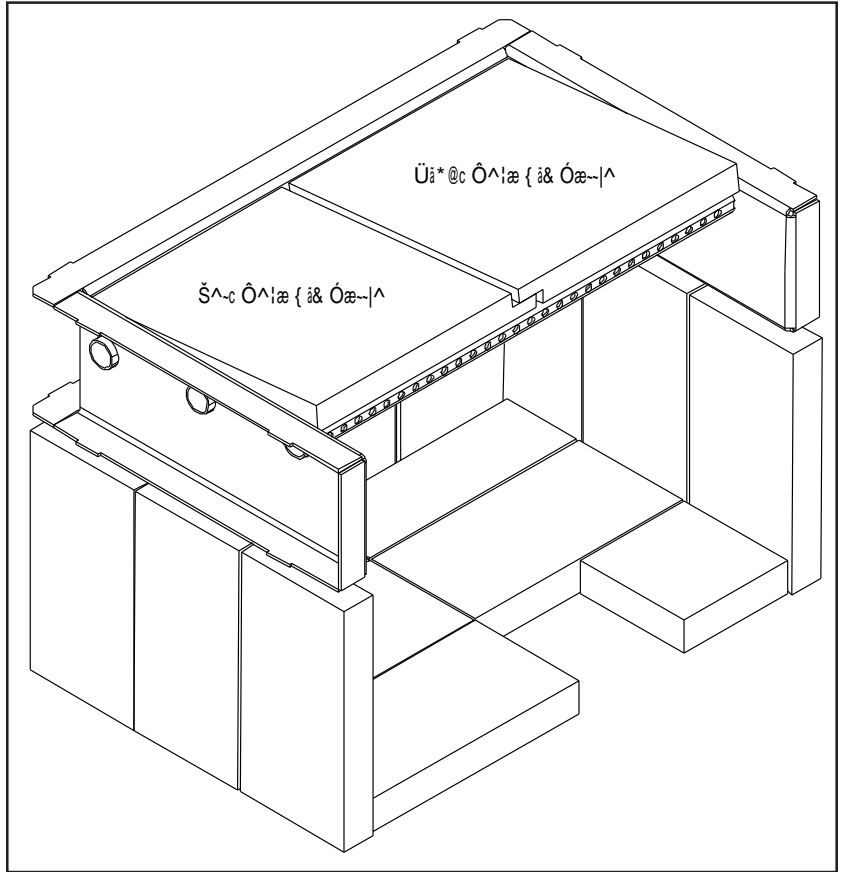

:] [i` fY`)` ' . `=bghU` Uh]cb` cZ` 7YfUa`]W6UZJY`"

: 5B` K` =F=B; `8` =5; F5AG.

H]g` Udd`]UbWz` k` \Yb`]bghU` YXz` a` i` gh` VY` Y` YWf]W` m` Vzb` bY` W]X` UbX` [fci` bXYX`]b` UWv` fX` UbW` k`]h` ` cW` Vt` XYg` cf`]b` HAY` UVg` YbW` cZ` cW` Vt` XYg` z` k`]h` HAY` W` ffY` bh` 7G5` 7&&` %` 75B58` -5B` `9@97HF` =75@7C89`" DUfhi` %ž` G5: 9HMGH5B85F8G: CF` `9@97HF` =75@` =BGH5@5H` =CBGž` cf` H` <9` B5H` =CB5@9@97HF` =75@7C89` 5BG` =#` B: D5` +` \$`]b` HAY` I` G5`"

75I` H=CB` `@UWY` U` `k`]fYg` df]cf` hc` X]g` Vzb` bY` W]cb` k` \Yb` gYfj`]M]b[` Vt` b` h` c` g` "K`]f]b[` Yff` c` fg` W]b` W]i` gY`]a` dfcd` Yf` UbX` XUb[Yfci` g` cd` Yf` Uh]cb` "J` Yf]Z` mdfcd` Yf` cd` Yf` Uh]cb` UZ` h` Yf` gYfj`]M]b["

H]g`]g` U` VUg]Wk`]f]b[` X]U[fUa` `Zcf` HAY` cd]cb` ZUb`]bghU` Uh]cb`"

%ž` Di` [` HAY` ZUb` UggY` a` Vm]bhc` U` h` fY` fl` E` dfcb[` f[fci` bXYX` E` fY` Wdh` UWY`"

&E` H` fb` HAY` ZUb` Vt` b` h` c` Yf` hc` HAY` XYg]fYX` gYh]b[` "

'` E` CbW` HAY` i` b]h` \Ug` fY` UWYX` cd` Yf` Uh]b[` h` Ya` dYf` Uhi` fYz` HAY` ZUb` h` Ya` dYf` Uhi` fY` gY` bgcf` k`]` hi` fb` HAY` ZUb` cb` Ui` hca` Uh]W` m`"

(E` K` \Yb` HAY` i` b]h` Vt` c` g` Xck` b` HAY` ZUb` h` Ya` dYf` Uhi` fY` gY` bgcf` k`]` g` li` h` HAY` ZUb` cZ` Ui` hca` Uh]W` m`"

=bghU` `Uh]c b

8C 'c]` h\Y`ZUb`VYUf]b[g'fY[i`Uf'm'

8C 'BCH`Whcf`fYa`cj`Y`h\Y`[fci`bX]b[`dfcb[`Zca`h\Y`d'i`[" "

8C 'BCH`fci`h\Y`dck`Yf`WfX`VYbYUa`h\Y`YUhf`

K 5FB=B; .`h\]g`Udd`]UbW`]g`Yei`]ddYX`k`]h`U`h`fY`!`dfcb[`f[fci`bX]b[`E`d'i`[`Zcf`nci`f`dfch`V]cb`U[U]bgh`
g`cW` \`UnUfX`UbX`g`ci`X`VY`d'i`[[YX`]bhc`U`dfcdYf`m[fci`bXYX`h`fY`!`dfcb[`fYWd`H`UW`"

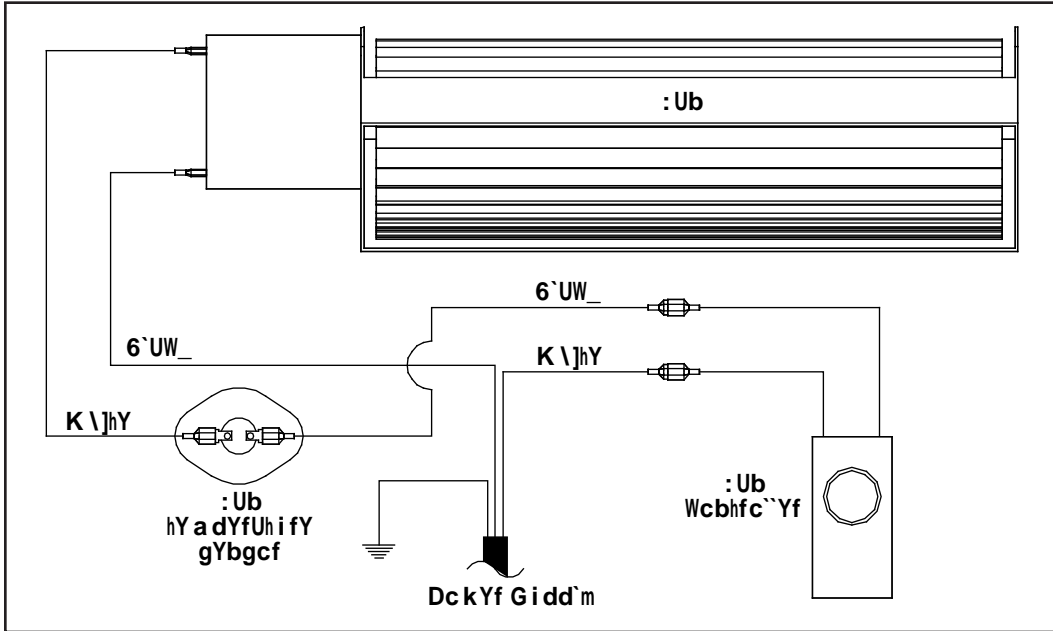

:] [i fY) (. : fYg`h`bX]b[: Ub ?]hK]f]b[`8]U[fUa "

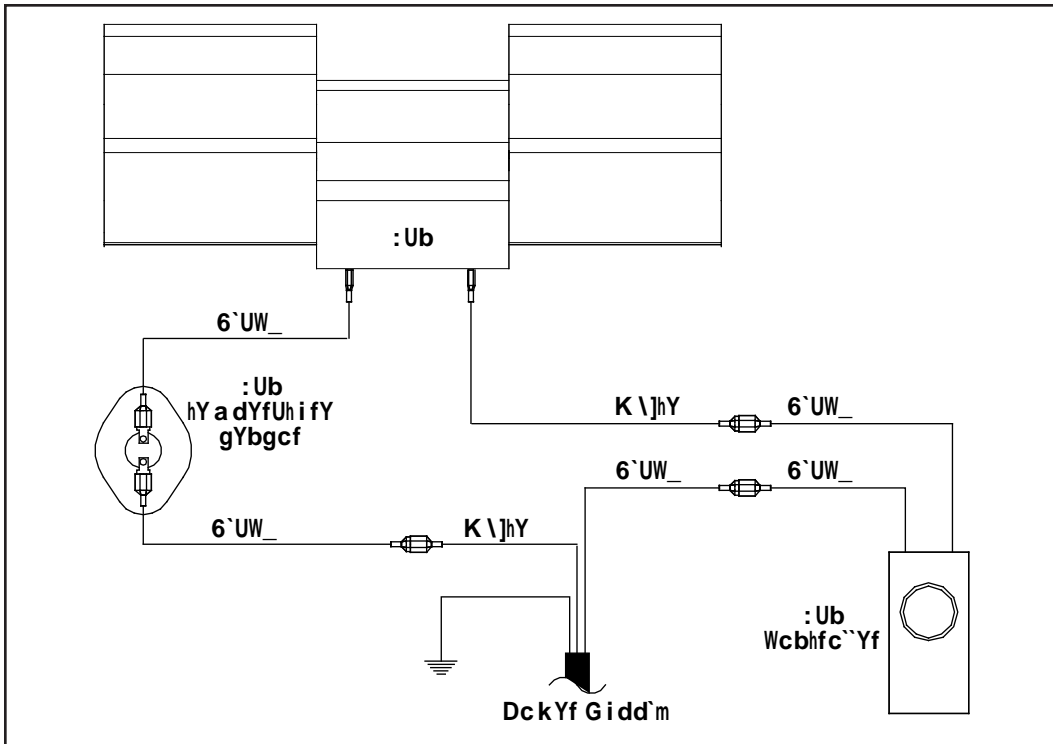

:] [i fY) . :]fYd`UW`=bgYfh: Ub ?]hK]f]b[`8]U[fUa "

=b g h U ` ` Uh]c b

CDH-CB5@: 5B `=BGH5@5H-CB !: F 99GH5B8-B; .

FYZf'hc': 5B`K `=-B; `8-5; F5A`VYZcfY`]bghU`]b[`nci f`cdh]cbU`ZUb`
_]h'

%`FYa cj Y`hY`ZUb`UggYa V`mi Zfca`hY`Vcl`UbX`]bghU`Vmi Zcf`
Ubm XUa U[Y`hc`hY`UggYa V`m`=-Z XUa U[Y`]g`bch]WX`VU`
nci f`XYUYfz`X]ghf]Vi hcf`cf`Vti f]Yf`Vta dUbm UbX` \Uj Y`
Vta dcbYbgh`fYd`UWX`VYZcfY`]bghU`]b[`_]h'

&`FYa cj Y`hY`_bcW`ci hUh`hY`Vchca`cZ`hY`VUW`dUbY`cZ`
hY`Udd`]UbW`Vmi g]b[`U`UUh`YUX`gVYk Xfj] Yf`Ug`U`Yj Yfz`
\cc`_hY`hd`cZ`hY`gVYk Xfj] Yf`i bXYf`hY`dUbY`VYg]XY`hY`
hUg`UbX`di g`hY`dUbY`ci h'

'`=-bghU`hk c`f&L`H`&\$`gVYk`g]bhc`hY`hcd`hk c`f&L`c`Yg`D`UW`
hY`Vck`Yf`UggYa V`micj`Yf`hY`Yg`hk c`f&L`gVYk`g'

("`9bgj`fY`hY`hYa dYfU`h`fY`gYbgcf`k`]`hci W`hY`i b]h`k`Yb`
a`ci bhYX`=-Z]hXcYg`bch]ci`Wz`UX`gh`hY`gYbgcf`gc`]hXcYg`
h]`[\`hYb`hY`hk c`f&L`hcd`gVYk`g`UbX`]bghU`hY`hk c`f&L`
Vchca`gVYk`g`UbX`h]`[\`hYb`"

)`D`i`[`hY`ZUb`UggYa V`m]b`UbX`WYW`Zcf`dfcdYf`cdYfU]cb`"

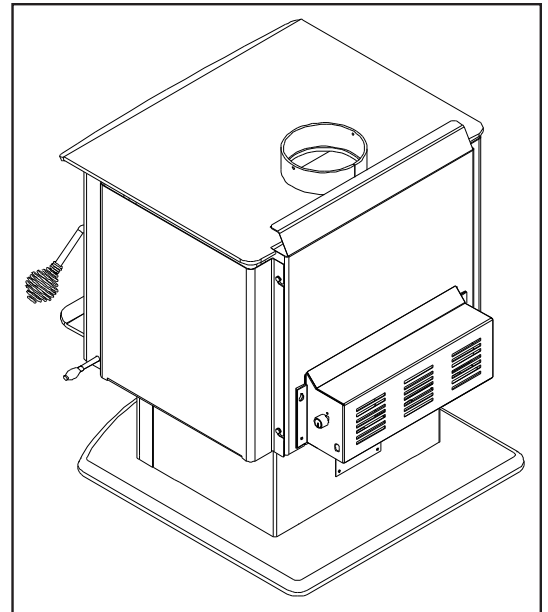

:] [i fY) * . `6UW`J`Yk`cZ: fYg]UbX]b[`i b]h`
k]h : Ub ?]h'

: 5B `F 9A CJ 5@!`=-BG9FH

H`Y`=-bgYfhi`Vta`Yg`k`]h`hY`ZUb`UggYa`VYX`
]bghU`YX`]b`hY`Y`Zi`g`fci`X`=-Z`8YVt`fU]j`Y`D`U]g`
UfY`hc`VY`]bghU`YXz`hY`ZUb`UggYa`V`mia`i`gh`VY`
fYa`cj`YX`Zfca`hY`g`fci`X`fFYZf`hc`Í`F`9A`CJ`5@`C`:
H`k`9`G`<`FCI`8G`!`=-BG9FH`L`"

%`8]gVt`bbYVt`U`Y`YVt]VU`Vt`bbYVt]cbg`Zcf`hY`
ZUb`_]h'

&L`FYa`cj`Y`hY`Zci`f`f(L`Í`YI`YUX`gVYk`g`h`Uh`
\`c`X`hY`ZUb`a`ci`bh]b[`d`U]h`hc`hY`g`fci`X`=-Z`
Xc]b[`U`ZUb`cb`m`fYd`UW`a`Ybhz`fYa`cj`Y`hY`
Zci`f`f(L`H`&\$`gVYk`g`\`c`X]b[`hY`ZUb`hc`hY`
ZUb`a`ci`bh]b[`d`U]h`"

'`L`FYa`cj`Y`hY`ZUb`Vt`bhc`_bcV`UbX`bi`h`Zfca`
hY`Zfcb`cZ`hY`g`fci`X`UbX`di`hY`Vt`bhc`g`
ci`h`hY`VUW`"

(L`=-bghU`hY`ZUb`_]h]bhc`hY`bYk`g`fci`X`Vmi`
Zc`ck]b[`fYj`Yfg]b[`ghYdg`%`hc`'`FYZf`hc`
: 5B`K`=-B; `8-5; F5A`hc`Ybgj`fY`hY`ZUb`]g`
fYVt`bbYVt]X`dfcdYf`m`"

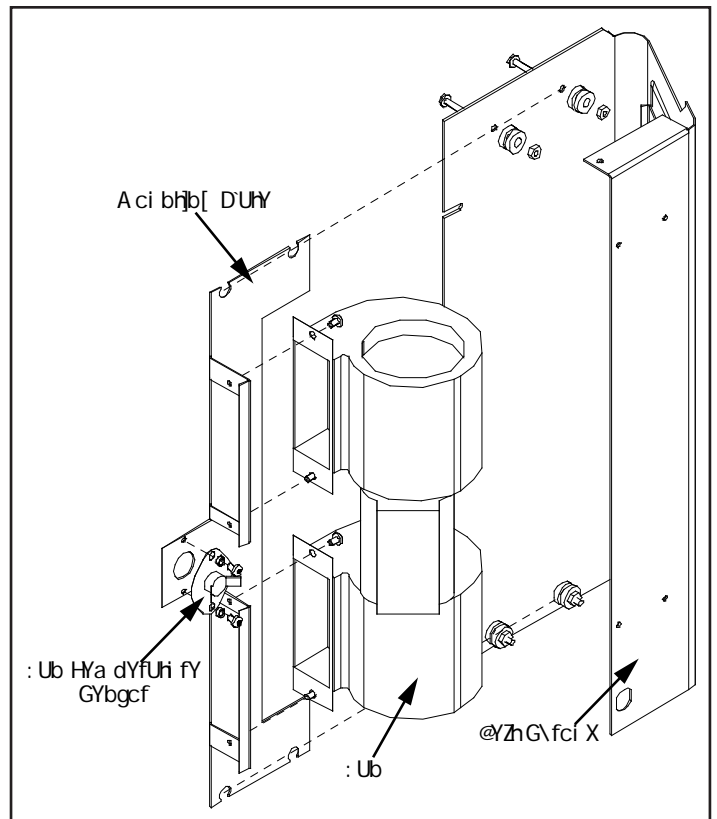

:] [i fY) + . `=-bgYfhi`b]h`k`]h : Ub`"

=bghU` `Uh]c b

F9ACJ5@C: Hk9G<FCI 8G!` =BG9FH

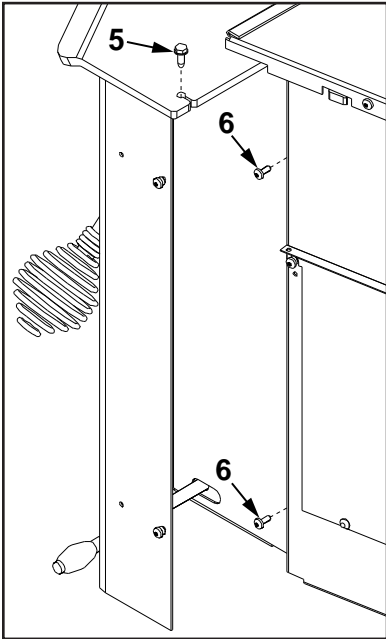

: [(i fY) , . FYa cj U`cZf] [\hi dcX"

%` =ZHY'gj ffc i bX'dUbY`]g]bghU`YXz'fYa cj Y`]hVm]Z]b[`hY'dUbY` g'fU] [\hi i d'hYb'ci H'

&"" : cf hY'f] [\hg\fc i Xz'rk]ghhY'\UbX'Y'cb`hY'U]f`Vt'bf'c`'Vt'Wk]gY'hc` fYa cj Y`]hZ'ca `hY'fcX"

' "" Di ``i b]hZ'cfk UfX'U'Z'k`]bWYgž`]Z'ccgg]VY"

("" FYa cj Y`hY` g'WYk ž i g]b[`U`) #&I` gcWYh'cf` k fYbWz` hUh [cYg' Xck b` h'fci [\ `hY'U'fYVcl` 'hcd`]bhc` U'VYbhcj Yf`hUV` Uh'hY` hcd` cZ'hY` g'fci X` fgy'5`]b : [(i fY) , E"

) "" hY` g'fci Xg`Wb`VY` fYa cj YX`cbY`cZ'rk`c`k`Uhq

U"" : cf hY` U'fgh` a Yh'cXz` di `` hY`]bg]XY`YX[Y`cZ'hY` g'fci X` g'fU] [\hi ci hz'Uddfc]]a UH`m` I` f&Wd` Ež`]b`cfXYf`hc` i b'cc`_hY` g'fci X`Z'ca` i b]h`Di `` hY` g'fci X`ci h'h'fci [\ `hY` g]XY"

V"" : cf hY` g'Vt'bx` a Yh'cX` f'fVt'a a YbXYX` Zc' hY` f] [\hi g'fci X'z' fYa cj Y`hY` rk`c`f&E`H`&\$` g'WYk` g'hUh`c`X`hY` g'fci X`hc` hY` i b]h` fgy'6`]b : [(i fY) , E"Di `` hY` g'fci X`ci h'h'fci [\ `hY` g]XY"

* "" Hc`]bghU` hY` g'fci Xz'Zc`ck` g'hdg`%h'fci [\)`]b`fY] YfgY`cfXYf`'9bgj` fY` hY` g'fci Xg`UfY`_cc`_YX`VY\]bX`Vch` g'WYk` g'cb`Y]hYf`g]XY"

=BG5@5HCB` C: Hk9`897CF 5HJ 9`D@5H9G!` =BG9FH

%` FYa cj Y`hY` g'fci X`Z'ca` `hY` i b]h`fYzYf` hc` I` F9ACJ5@C: Hk9` G<FCI 8G!` =BG9FH`E

&"" FYa cj Y`hY`Z'ub`Z'ca` `hY`Y'Z'ig\fc i X`fYzYf`hc` I` : 5B`F9ACJ5@!` =BG9FH`E

' "" I` bZ'ghYb`hY`rk`c`f&E`bi`hg`hUh'gYW'fY`hY`d`UHY`hc` hY` g'fci X`" hY`bi`hg` g'fci X`cb`m'VY`_UbX!h] [\hYbYX`Vi`hU`) #&I` k` fYbW`a` Um'VY`fYei`]fYX"

("" FYa cj Y`hY`c`X`d`UHY`Z'ca` `hY` g'fci X`UbX`fYa`cj`Y`hY`j`]VfU]cb`Vi` a`dYf`Z'ca` `hY`d`UHY`" @Uj`Y`hY`k`Ug`Yfg`cb`hY` g'fci X`

) "" =bghU` hY` j`]VfU]cb`Vi` a`dYf`]bhc` hY` bYk` XYVt'fU]j` Y`d`UHY` UbX`]bghU` bYk`d`UHY`cbhc` hY` g'fci X`

* "" <UbX!h] [\hYb`hY`rk`c`f&E`bi`hg`VUW`]bhc`d`UW"

+"" FY!]bghU` hY`Z'ub`]bhc` hY`Y'Z'ig\fc i X`

, "" FY!]bghU` hY` g'fci Xg`cbhc` hY` i b]h`

BchY. hY` Y'Zi`XYVt'fU]j` Y`d`UHY` \Ug` fYVt'ub[`i`Uf` \c`Yg` UbX` hY` f] [\hi XYVt'fU]j` Y`d`UHY`XcYg`bch`

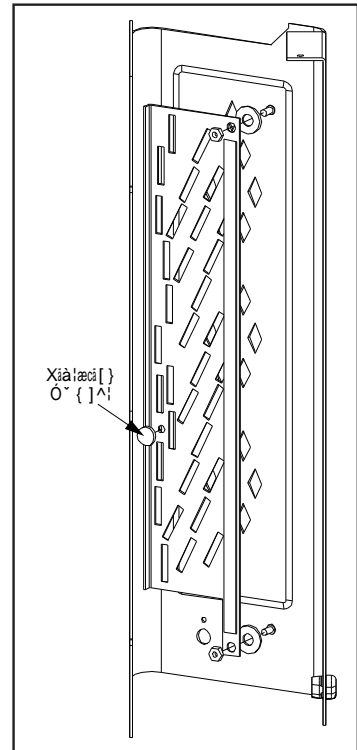

: [(i fY) - . 7\Ub[]b[` XYVt'fU]j` Y`d`UHY`

=bghU` Uh]c b

=BGH5@5HCB`C: Hk9`G FFCI B8`D5B9@!`=BG9FH.

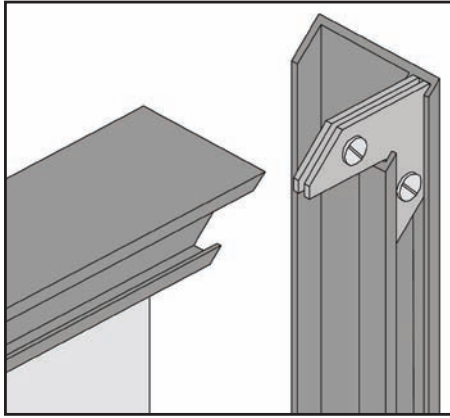

:][i fY`*\$.`7cfbYf VfUWYhg`Zcf`hf]a` "

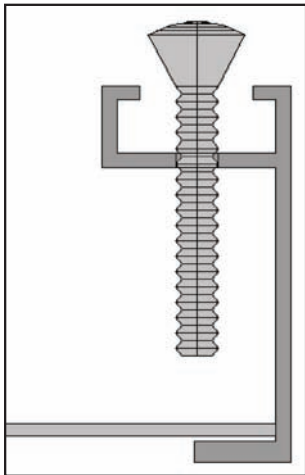

:][i fY`* &.`GVWYk`hc`c`X` HkY`hf]a` U[U]bghHkY`g` f!` fci`bX`"

=bghU` Uh]cb`cZHf]a` .

HkY` hf]a` gYh`Zcf` nci` f` gi` ffc`i` bX` dUby` a` i` gh` VY`]bghU`YX` VYZcfY`]bghU`]b[` hY` gi` ffc`i` bX` dUby` cbrc` hY` i` b]h`]ZbchU`fYUXmXcbY`"

%` 5HUM` cbY` g]XY` hf]a` hc` hY` hcd` hf]a` ž` i` g]b[` U` VefbYf` VfUWYh` fgY` :][i` fY` *\$E` hc` gYWFY` d]YWG` hc[` YhYf` HkYfY` UfY` h` c` f&E` a` U]b` d]YWG` hc` YUM` VefbYf` VfUWYh` fgY` :][i` fY` *%E` K` \Yb`]bghU`]b[` hY` VefbYf` d]YWG`]brc` hY` hf]a` ž` hY` I` 6` : 579I` g]XY`g` a` i` gh` ZUW` YUM` chYf` UbX` hY` gVWYk` \YUX`g` UfY` hc` ZUW` ci` h` K`]h` hY` VfUWYh`]b` d` UW` UbX`

HkY` hcd` UbX` U` g]XY` hf]a` gbi` [` hc[` YhYf` i` gY` U` UUh` \YUX` gVWYk` Xf]j` Yf` hc` h` fb` hY` h` c` f&E` gVWYk` g`]b` hY` VfUWYh` hc` h[` \hYb`]h`]brc` hY` hf]a` "

"`G]XY` hY` h` c` f&E` UHUMYX` hf]a` d]YWG` cbrc` hY` gi` ffc`i` bX` dUby`"

("`5HUM` hY` chYf` g]XY` hf]a` d]YWG` hc` hY` hcd` hf]a` ž` i` g]b[` hY` g]a` Y` a` Yh` c` X` i` gYX`]b` GHYd` %`

)`DUM` hY` gVWYk` bX` g]XY` cZ` hY` hf]a` cb` hY` gi` ffc`i` bX` dUby`]b` hY` g]a` Y` a` UbbYf` i` gYX` cb` hY` Ufgh` g]XY` UbX` gYWFY`]b` hY` g]a` Y` a` UbbYf`

*`Cb` hY` g]XY` hf]a` gž` hY` fY` UfY` \c` Yg` &I` f) \$` a` a` E` Zfca` Y]hYf` YbX` I` gY` U` D\`]dg` gVWYk` Xf]j` Yf` hc` d` UW` U` ,` gVWYk` %` I` cb[`]b` YUM` \c` Y` UbX` h[` \hYb` ffYZf` hc` :][i` fY` * &E` Hk]g` k`]` _YYd` hY` hf]a` h[` \hU[U]bgh` hY` gi` ffc`i` bX`"

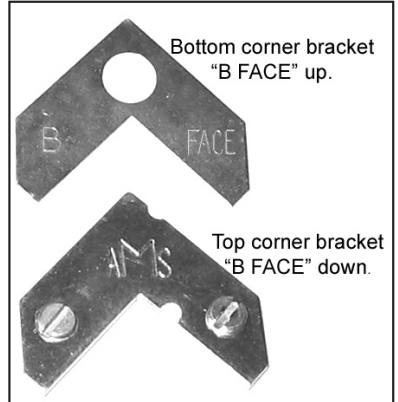

:][i` fY` *` %` Hk` c` d]YWG` cZ` VefbYf` VfUWYh`"

=bghU` Uh]cb`cZGi` ffc`i` bX` DUby` cbrc` I` b]h

HkYfY` UfY` h` c` f&E` \cc`_g` cb` Y]hYf` g]XY` cZ` hY`]bg]XY` cZ` hY` dUby` @bY` i` d` hY` cdYb]b[` g` cb` hY` \cc`_g` k`]h` hY` gVWYk` g` cb` hY` ci` hg]XY` cZ` Y]hYf` g]fci` X` fgY` :][i` fY` *` E` Di` g` hY` gi` ffc`i` bX`]b` UbX` di` g`]h` Xck` b`]brc` d` UW`"

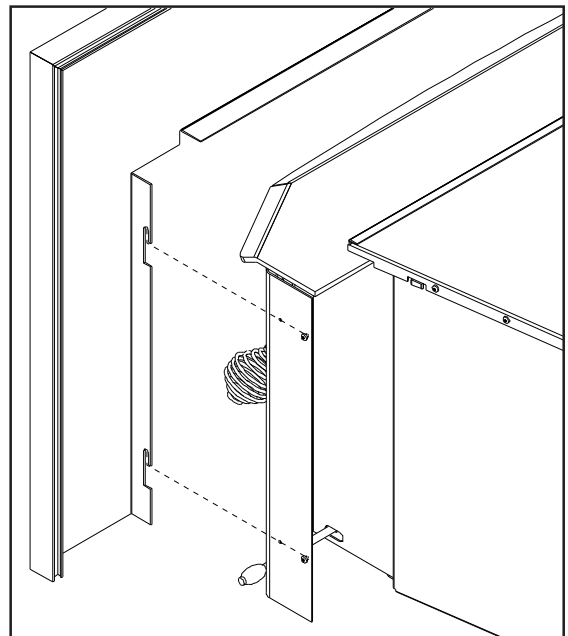

:][i` fY` *` .` =bghU` Uh]cb` cZ` DUby`"

DUf hg '@]gh

| FYZfUbW` | 8YgW]dh]cb | DUfh` |
|----------|---|-------------|
| % | %&\$\$. 'f(- 57E'7YfUa]W: Ub`HYa dYfUhi fY`GYbgcf | 97!\$\$% |
| & | : D=: Ub`7cblfc`Yf!`%0) J | 97!\$' - |
| & | : Ub`7cblfc`Yf`?bcV | 97!\$((\$ |
| ' | 8ca Yg]Wdck Yf`VzFX!`%0) J | 97!\$(& |
| | %&\$\$/`%+\$\$': fYYghUbX]b[`7cbj YW]cb`6`ck Yf!`%0) J | 97!\$* - |
| (| 8ccf'; Ug_Yh!`+'ZYhf&`% a t | 9: !% , |
| | : fYg\`5]f`?)h | 9: !% * |
|) | CbY`@Y[`!`DU]bhYX | 9: K!&)' |
|) | CbY`@Y[`!`; c`X | 9: K!&)(|
|) | CbY`Y[`!`b]WY` | 9: K!&)) |
| * | : fYYghUbX]b[`: Ub`?)h | 9: K!&`*% |
| + | ; `Ugg`k]h`HudY | %\$!\$\$\$ |
| , | 8Ua dYf`<UbX`Y`Gdf]b[`!`6fUgg | 9: !% % |
| , | 8Ua dYf`<UbX`Y`Gdf]b[`!`B]WY` | %\$!\$\$) |
| - | 8ccf`<UbX`Y`Gdf]b[`!`6fUgg | %\$!\$\$\$* |
| - | 8ccf`<UbX`Y`Gdf]b[`!`B]WY` | %\$!\$\$\$+ |
| %\$ | %&\$\$_@Y[`?)hk]h`Ug\`Xfuk Yf!`B]WY` |)\$!-+- |
| %\$ | %&\$\$_@Y[`?)hk]h`Ug\`Xfuk Yf!`; c`X |)\$!-, \$ |
| %\$ | %&\$\$_@Y[`?)hk]h`Ug\`Xfuk Yf!`DU]bhYX |)\$!-, % |
| %\$ | %&\$\$_@Y[`?)hk]h`Ug\`Xfuk Yf!`6fi g\YX`B]WY` |)\$!%(+\$ |
| %% | %&\$\$_: fYYghUbX]b[`DYXyghU`!`DU]bhYX |)\$!-, & |
| %& | %+\$\$`@Y[`?)hk]h`Ug\`Xfuk Yf!`B]WY` |)\$!-, ' |
| %& | %+\$\$`@Y[`?)hk]h`Ug\`Xfuk Yf!`; c`X |)\$!-, (|
| %& | %+\$\$`@Y[`?)hk]h`Ug\`Xfuk Yf!`DU]bhYX |)\$!-,) |
| %& | %+\$\$`@Y[`?)hk]h`Ug\`Xfuk Yf!`6fi g\YX`B]WY` |)\$!%(+% |
| % | %+\$\$': fYYghUbX]b[`DYXyghU`!`DU]bhYX |)\$!-, * |
| %{ | 8ccf!`DU]bhYX |)\$!-, + |
| %{ | 8ccf!`; c`X |)\$!-, , |
| %{ | 8ccf!`B]WY` |)\$!-, - |
| %{ | 8ccf!`6fi g\YX`B]WY` |)\$!%(*- |
| %0 | Ck bYfg]A Ubi U |)\$!%\$(\$ |
| %* | <YU`h9Z]W]bW]G\]Y`X |)\$!%\$, , |
| %+ | %&\$\$_/`%+\$\$': fcbhGYWtbXUfm5]f`H VY`5 |)\$!%\$- - |
| % | %+\$\$`FYUF`GYWtbXUfm5]f`H VY`7 |)\$!%\$\$\$ |
| %- | %+\$\$`A]XX`Y`GYWtbXUfm5]f`H VY`6 |)\$!%\$%\$ |
| &\$ | %&\$\$_`FYUF`GYWtbXUfm5]f`H VY`9 |)\$!%\$& |
| &% | %&\$\$_`A]XX`Y`GYWtbXUfm5]f`H VY`8 |)\$!%\$' |
| && | Di a]W`6f]Wg!`!`I`L`-I`f!`*`a`a`I`&&-`a`a`t |)\$!%\$(\$ |
| &' | Di a]W`6f]Wg!`!(`I`L`-I`f!`%\$(`a`a`I`&&-`a`a`t |)\$!%\$(\$) |

DUF hg '@]gh

| FYZfubW` | 8YgW]dh]cb | DUFh` |
|----------|--|--------------|
| &(| Di a]W`6f]Wg!:(Î`L`Î`Î`f%%(a a`i`%%(a a`t |) \$!%&\$* |
| &) | %&\$\$/`%+\$`5g\`8i a d`7cj Yf |) \$!%&\$ |
| &* | 8ccf`<UbX`Y`5ggYa V`mfF`cXz`7Ugh@UHwz`6fUgg`Gdf]b[`t |) \$!%&% |
| &+ | K`ccX`8ccf`;`Ugg`FYH]bYf`?`]h`fK`]h`GwYk`gk |) \$!%&& |
| &, | %&\$\$:`fYYghUbX]b[`:`UhHcd`@ZhiG]XY`7UV]bYh |) \$!%&' |
| &- | %&\$\$:`fYYghUbX]b[`:`UhHcd`F][`hG]XY`7UV]bYh |) \$!%&(|
| ' \$ | %&\$\$:`fYYghUbX]b[`:`GHYd`Hcd`@ZhiG]XY`7UV]bYh |) \$!%&) |
| ' % | %&\$\$:`fYYghUbX]b[`:`GHYd`Hcd`F][`hG]XY`7UV]bYh |) \$!%&* |
| ' & | %+\$\$:`fYYghUbX]b[`:`UhHcd`@ZhiG]XY`7UV]bYh |) \$!%&+ |
| '' | %+\$\$:`fYYghUbX]b[`:`UhHcd`F][`hG]XY`7UV]bYh |) \$!%&, |
| ' (| %+\$\$:`fYYghUbX]b[`:`GHYd`Hcd`@ZhiG]XY`7UV]bYh |) \$!%&- |
| ') | %+\$\$:`fYYghUbX]b[`:`GHYd`Hcd`F][`hG]XY`7UV]bYh |) \$!%&\$ |
| ' * | %&\$\$/`%+\$`@/[`?]h`5g\`8fuk`Yf |) \$!%&% |
| ' + | %&\$\$/`%+\$`@/[`?]h`5g\`8fuk`Yf`6cl |) \$!%& & |
| ' , | %+\$\$/`%+\$`@/[`?]h`5g\`8fuk`Yf`6cl |) \$!%& ' |
| ' - | %&\$\$/`%+\$`@/[`?]h`5XUdrcf`DUH |) \$!%& (|
| (\$ | %+\$\$/`%+\$`@/[`?]h`5XUdrcf`DUH |) \$!%&) |
| (% | %&\$\$/`%+\$`DYXgH`U`?`h`5g\`8fuk`Yf |) \$!%& * |
| (& | %&\$\$/`%+\$`:`]fYd`UW`=bgYfh: Ub`5ggYa V`m |) \$!%& *- |
| (& | %&\$\$/`%+\$`:`]fYd`UW`=bgYfh: Ub`Cb`m |) \$!%&%% |
| (' | %&\$\$/`%+\$`@ZhiG\]Y`X`5ggYa V`m |) \$!%&((|
| ((| %&\$\$/`%+\$`F][`hG\]Y`X`5ggYa V`m |) \$!%&() |
| () | %&\$\$/`7YfUa]W6UZjY`!`%D]YW |) \$!%&(* |
| (* | %+\$\$/`7YfUa]W6UZjY`!`%D]YW |) \$!%&(+ |
| (+ | %&\$\$/`%+\$`:`]fYd`UW`=bgYfh: `i`Y`7c`Uf`5ggYa V`m |) \$!%&(, |
| (, | FY[i`Uf`Gi`ffci`bX`DUbY`HF]a`!`6`UW |) \$!%&% |
| (, | FY[i`Uf`Gi`ffci`bX`DUbY`HF]a`!`;`c`X | %\$!`\$\$' |
| (, | FY[i`Uf`Gi`ffci`bX`DUbY`HF]a`!`B]WY` | 9: K`!`&*(|
| (- | Cj`YfghYX`Gi`ffci`bX`DUbY`HF]a`!`6`UW |) \$!%&& |
| (- | Cj`YfghYX`Gi`ffci`bX`DUbY`HF]a`!`;`c`X | %\$!`\$\$`(` |
| (- | Cj`YfghYX`Gi`ffci`bX`DUbY`HF]a`!`B]WY` |) \$!%`(` |
|)\$ | :`]fYd`UW`=bgYfhFY[i`Uf`Gi`ffci`bX`DUbY` |) \$!%&+& |
|)% | :`]fYd`UW`=bgYfhCj`YfghYX`Gi`ffci`bX`DUbY` |) \$!%&+% |
|)& | :`]fYd`UW`=bgYfh@ZhiG\fc`i`X |) \$!%&+(` |
|)' | :`]fYd`UW`=bgYfhF][`hG\fc`i`X |) \$!%&+) |
|) (| 8YV&fU]j`Y`G\fc`i`X`DUH`g`7\UfV&U`fGYhcZ&k |) \$!%&- |
|) (| 8YV&fU]j`Y`G\fc`i`X`DUH`g`5bh]ei`Y`7cddYf`fGYhcZ&k |) \$!%&(\$ |
|) (| 8YV&fU]j`Y`G\fc`i`X`DUH`g`;`c`X`fGYhcZ&k |) \$!%&(% |
|) (| 8YV&fU]j`Y`G\fc`i`X`DUH`g`B]WY`fGYhcZ&k |) \$!%&(& |

