



**E20** Gas Insert

**OWNERS MANUAL**



**FOR YOUR SAFETY**

**Do not store or use gasoline or other flammable vapours and liquids in the vicinity of this or any other appliance.**

This appliance is only for use with the type of gas indicated on the rating plate. This appliance is not convertible for use with other gases, unless a certified kit is used.

**WARNING: If the information in this manual is not followed exactly, a fire or explosion may result causing property damage, personal injury or loss of life. Installation and service must be performed by a qualified installer, service agency or the gas supplier.**

**INSTALLER:**

Leave this manual with the appliance.

**CONSUMER:**

Retain this manual for future reference.

**WHAT TO DO IF YOU SMELL GAS**

- Open windows/extinguish any open flame.
- Do not try to light any appliance.
- Do not touch any electrical switch or use any phone in your building.
- Immediately call your gas supplier from a neighbour's phone. Follow the gas supplier's instructions.
- If you cannot reach your gas supplier, call the fire department.



Massachusetts installations (Warning): This product must be installed by a licensed plumber or gas fitter when installed within the Commonwealth of Massachusetts. Other Massachusetts code requirements: Flexible connector must not be longer than 36in., a shut off valve must be installed; only direct vent sealed combustion products are approved for bedrooms/bathrooms. A carbon monoxide detector is required in all rooms containing gas fired direct vent appliances. The fireplace damper must be removed or welded in the open position prior to installation of a fireplace insert.



*SHERWOOD INDUSTRIES IS AN ENVIRONMENTALLY RESPONSIBLE COMPANY. THIS MANUAL IS PRINTED ON RECYCLED PAPER.*

**PLEASE KEEP THESE INSTRUCTIONS FOR FUTURE REFERENCE**

**50-2261**

# SAFETY PRECAUTIONS

## FOR SAFE INSTALLATION AND OPERATION OF YOUR “ENVIRO” HEATER, PLEASE CAREFULLY READ THE FOLLOWING INFORMATION:

- All ENVIRO gas-fired appliances must be installed in accordance with their instructions. Carefully read all the instructions in this manual first. Consult the building authority having jurisdiction to determine the need for a permit prior to commencing the installation.
- **NOTE:** Failure to follow these instructions could cause a malfunction of the fireplace, which could result in death, serious bodily injury, and/or property damage.
- Failure to follow these instructions may also void your fire insurance and/or warranty.

### GENERAL

- Installation and repair should be done by a qualified service person. The appliance should be inspected before the first use and, at least, annually by a qualified service person. More frequent cleaning may be required due to excessive lint from carpeting, bedding material, etc. It is imperative the control compartments, burners and circulating air passageways of the appliance be kept clean.
- Due to high temperatures, the appliance should be located out of high traffic areas and away from furniture and draperies.

### Children and adults should be alerted to the hazards of high surface temperatures and should stay away to avoid burn or clothing ignition.

- Young children should be carefully supervised when in the same room as the appliance. Toddlers, young children and others may be susceptible to accidental contact burns. A physical barrier is recommended if there are at risk individuals in the house. To restrict access to a fireplace or stove install an adjustable safety gate to keep toddlers, young children and other at risk individuals out of the room and away from hot surfaces.
- Clothing or other flammable materials should not be placed on or near the appliance.

### FOR YOUR SAFETY

- Installation and service must be performed by a qualified installer, service agency or gas supplier.
- This installation must conform to local codes or, in the absence of local codes, to the current CAN/CGA-B149 installation code (Canada) or National Fuel Gas Code ANSI Z223.1.2 (USA)
- To prevent injury, do not allow anyone who is unfamiliar with the stove to operate it.

**To prevent injury, if the pilot or pilot and burners have gone out on their own, open the glass door and wait 5 minutes to air out before attempting to re-light the stove.**

- Always keep the area around these appliances clear of combustible material, gasoline and other flammable liquids and vapours.
- These appliances should not be used as a drying rack for clothing or for hanging Christmas stockings/decorations.
- Due to the paint curing on the stove, a faint odor and slight smoking will likely be noticed when the stove is first used. Open a window until the smoking stops.

Always connect this gas stove to a vent system and vent to the outside of the building envelope. Never vent to another room or inside the building. Make sure the specified vent pipe is used, properly sized and of adequate height to provide sufficient draft. Inspect the venting system annually for blockage and signs of deterioration.

**WARNING:** Failure to position the parts in accordance with the diagrams in this booklet, or failure to use only parts specifically approved with this appliance, may result in property damage or personal injury.

**WARNING:** Do not operate with the glass front removed, cracked or broken. Replacement of the glass should be done by a licensed or qualified service person.

- Never use solid fuels such as wood, paper, cardboard, coal, or any flammable liquids, etc., in this appliance.

• Do not use this heater if any part has been under water. Immediately call a qualified service technician to inspect the heater and to replace any part of the control or gas control systems that have been under water.

- Do not abuse the glass by striking it or slamming the door shut.

• If the E20 unit is pulled out of its installation, and the vent-air intake system is disconnected for any reason, ensure that the vent-air intake pipes are reconnected and re-sealed in accordance to the instructions noted in INITIAL INSTALLATION - VENTING FIREPLACE INSERTS.

## **WARNING**



**HOT GLASS WILL  
CAUSE BURNS  
DO NOT TOUCH GLASS  
UNTIL COOLED.  
NEVER ALLOW  
CHILDREN TO TOUCH  
GLASS.**

# TABLE OF CONTENTS

---

Safety Precautions.....	2
Table of Contents.....	3
Codes And Approvals.....	4
Specifications.....	5
Rating Label Location.....	5
Dimensions.....	5
E20 Options Dimensions.....	6
Operating Instructions.....	7
Lighting and Turning Off Instructions.....	7
Pilot Light.....	8
Venturi Adjustment.....	8
Normal Sounds During Operation.....	8
Burner Lighting.....	9
Blower Speed.....	9
Maintenance And Service.....	10
Cleaning The Glass.....	10
Cleaning The Firebox.....	10
Replacing The Glass.....	10
Check Pilot and Burner Flames.....	10
Glass Door Removal.....	11
Cleaning The Painted Surfaces.....	11
Removing Valve Cover.....	12
Fuel Conversion.....	12
Initial Installation.....	15
Clearances to Combustibles.....	15
Minimum Fireplace Size.....	15
Direct Vent Model.....	15
Preparing Your E20 For Installation.....	16
Venting Fireplace Inserts.....	17
Direct Vent Vertical Vent Termination.....	19
Electrical Requirements.....	21
Gas Line Connection.....	22
Adjusting The Pilot Flame.....	24
Secondary Installation.....	25
Optional Base Shelf & Riser.....	25
Surround Panel Installation.....	26
Brick Panel Installation.....	27
Log Set and Ember Installation.....	28
Trouble Shooting.....	31
Parts List.....	32
Parts Diagram - Components.....	34
Parts Diagram - Options.....	35
Warranty.....	36
Installation Data Sheet.....	39

# CODES AND APPROVALS

**DIRECT VENT:** This type is identified by the suffix DV. This appliance draws all of its air for combustion from outside the dwelling, through a specially designed vent pipe system.

This appliance has been tested and approved for installations from 0 feet to 4500 feet (1372 m) above sea level.

**In the USA:** The appliance may be installed at higher altitudes. Please refer to your American Gas Association guidelines which state: the sea level rated input of Gas Designed Appliances installed at elevations above 2000 (610 m) feet is to be reduced 4% for each 1000 feet (305 m) above sea level. Refer also to local authorities or codes which have jurisdiction in your area regarding the de-rate guidelines.

**In Canada:** When the appliance is installed at elevations above 4500 feet (1372 m), the certified high altitude rating shall be reduced at the rate of 4% for each additional 1000 feet (305 m).

- This appliance has been tested by INTERTEK and found to comply with the established VENTED GAS FIREPLACE HEATER standards in CANADA and the USA as follows:

## VENTED GAS FIREPLACE HEATER (E20 DV; NG/LPG)

TESTED TO: ANSI Z21.88-2005/CSA 2.33-2005 VENTED GAS FIREPLACE HEATERS

CAN/CGA 2.17-M91 GAS FIRED APPLIANCES FOR HIGH ALTITUDES

CSA P.4.1-02 TESTING METHOD FOR MEASURING ANNUAL FIREPLACE EFFICIENCY

### This ENVIRO E20 Fireplace:

- Has been certified for use with either natural or propane gases. (See rating label.)
- Is not for use with solid fuels.
- Is approved for bedroom or bed sitting room. (**IN CANADA:** must be installed with a permanent wall thermostat for bedroom installations is required. Consult the authority having local jurisdiction in your area. **IN USA:** see current ANSI Z223.1 for installation instructions.)
- Must be installed in accordance with local codes. If none exist, use current installation code CAN/CGA B149 in Canada or ANSI Z223.1/NFPA 54 in the USA.
- Must be properly connected to an approved venting system and not connected to a chimney flue serving a separate solid-fuel burning appliance.
- Is not approved for closet or recessed installations.

**IMPORTANT NOTICE (Regarding first fire up):** When the unit is turned on for the first time, it should be turned onto high without the fan on for the first 4 hours. This will cure the paint, logs, gasket material and other products used in the manufacturing process. It is advisable to open a window or door, as the unit will start to smoke and can irritate some people. After the unit has gone through the first burn, turn the unit off, let the unit get cold then remove the glass door and clean it with a good gas fireplace glass cleaner, available at your local ENVIRO dealer. See "DOOR REMOVAL" and "CLEANING THE GLASS" sections.

NATIONAL  
FIREPLACE  
INSTITUTE



CERTIFIED

[www.nficertified.org](http://www.nficertified.org)

We recommend that our gas hearth products be installed and serviced by professionals who are certified in the U.S. by the National Fireplace Institute® (NFI) as NFI Gas Specialists.

# SPECIFICATIONS

## RATING LABEL LOCATION:

The rating label is located on the left side of the unit and is attached to a rectangular metal sheet that is chained to the fireplace.

## DIMENSIONS:

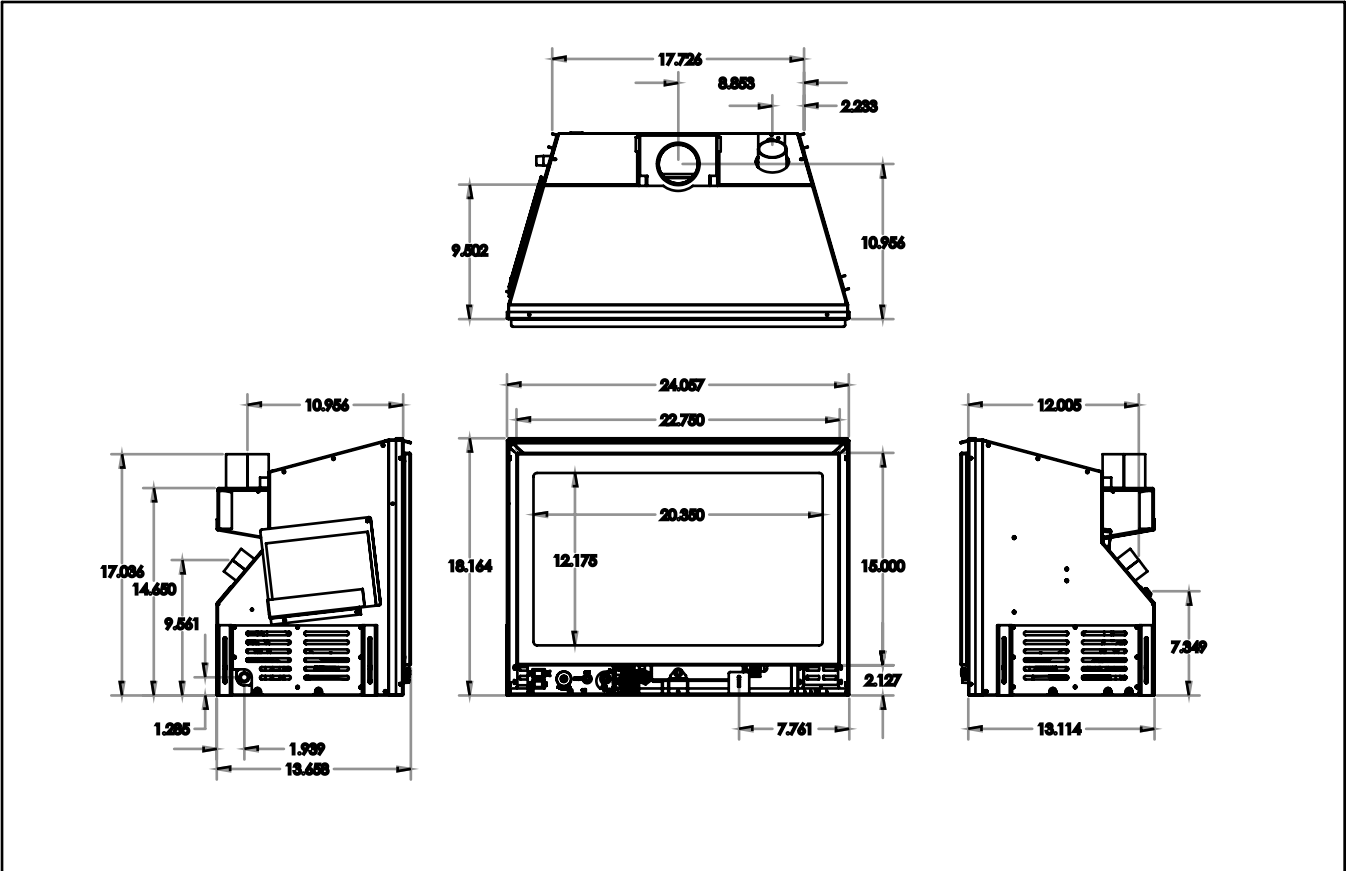
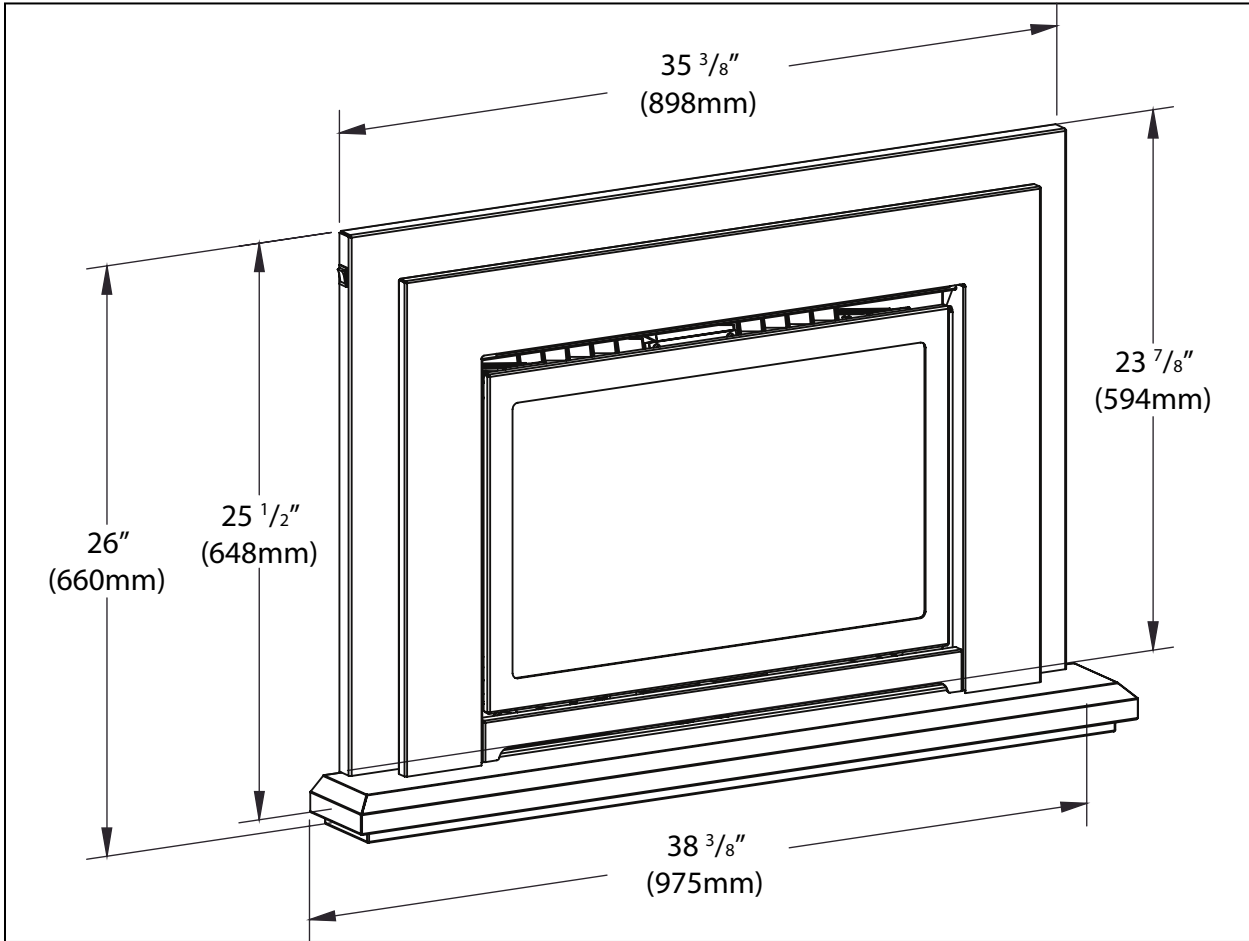


Figure 1: E20 Exterior Dimensions.

# SPECIFICATIONS



**Figure 2: E20 Contemporary Surround with Base Shelf and Riser.**

**Table 1: E20 Options Dimensions.**

	<b>Regular Surround</b>	<b>Contemporary Surround</b>	<b>Extruded Surround</b>
Height	23 <sup>7</sup> / <sub>8</sub> " (594mm)	23 <sup>7</sup> / <sub>8</sub> " (594mm)	23 <sup>7</sup> / <sub>8</sub> " (594mm)
Width	35 <sup>3</sup> / <sub>8</sub> " (898mm)	35 <sup>3</sup> / <sub>8</sub> " (898mm)	35 <sup>3</sup> / <sub>8</sub> " (898mm)
<b>Trimnable Surround</b>	Height		Width
	28 <sup>3</sup> / <sub>4</sub> " (705mm)		41 <sup>13</sup> / <sub>16</sub> " (1062mm)
	<b>Base Shelf</b>		<b>Base Shelf Riser</b>
Height	1 <sup>5</sup> / <sub>8</sub> " (41mm)		2 <sup>1</sup> / <sub>8</sub> " (54mm)
Width	38 <sup>3</sup> / <sub>8</sub> " (975mm)		36 <sup>7</sup> / <sub>8</sub> " (937mm)
Depth	Bottom 4 <sup>7</sup> / <sub>8</sub> " (112mm); Top 3 <sup>13</sup> / <sub>16</sub> " (97mm)		3 <sup>11</sup> / <sub>16</sub> " (94mm)

# OPERATING INSTRUCTIONS

**For Your Safety, Read Safety Precautions And Lighting Instructions Before Operating**

**WARNING: IF YOU DO NOT FOLLOW THESE INSTRUCTIONS EXACTLY A FIRE OR EXPLOSION MAY RESULT, CAUSING PROPERTY DAMAGE, PERSONAL INJURY OR LOSS OF LIFE.**

## LIGHTING AND TURNING OFF INSTRUCTIONS:

**CAUTION:** Hot while operating. Do not touch, severe burns may result. Keep children, clothing, furniture, gasoline or other flammable vapors away.

**CAUTION:** Do not operate this fireplace with the glass removed, cracked or broken. Replacement of the panel(s) should be done by a licensed or qualified person! This appliance needs fresh air for safe operation and must be installed with provisions for combustion and ventilation air. See installation and operating instructions manual. Keep burner and control compartment clean.



**WARNING:** Improper installation, adjustment, alteration, service or maintenance can cause injury or property damage, or loss of life. Refer to owner's information manual provided with this appliance. For assistance or additional information consult a qualified installer, service agency or the gas supplier. See installation and operating instructions accompanying appliance. Installation and service must be performed by a qualified installer, service agency, or the gas supplier.

### FOR YOUR SAFETY READ BEFORE OPERATING

**WARNING: IF YOU DO NOT FOLLOW THESE INSTRUCTIONS EXACTLY, A FIRE OR EXPLOSION MAY RESULT CAUSING PROPERTY DAMAGE, PERSONAL INJURY OR LOSS OF LIFE.**

- A) This appliance is equipped with a pilot, which must be lit by hand by following these instructions exactly.
- B) BEFORE LIGHTING smell all around the appliance area for gas and next to the floor because some gas is heavier than air and will settle on the floor.  
**WHAT TO DO IF YOU SMELL GAS:**  
Do not try to light any appliance. Do not touch any electrical switch: do not use any phone in your building. Immediately call your gas supplier from a neighbor's phone. Follow the gas suppliers instructions. If you cannot reach your gas supplier, call the fire department.
- C) Use only your hand to push in or turn the gas control knob; NEVER use tools. If the knob will not push in or turn by hand, do not try to repair it. Call a qualified service technician. Force or attempted repair may result in a fire or explosion.
- D) Do not use this appliance if any part has been under water. Immediately call a qualified service technician to inspect the appliance and to replace any part of the control system and any gas control which has been under water.


### LIGHTING INSTRUCTIONS

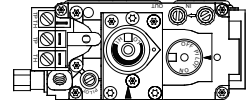
1. STOP! Read the safety information above on this label.
2. Turn off all electrical power to this appliance.
3. Turn off the gas control knob clockwise  to the off position.
4. Open door. Wait five (5) minutes to clear out any gas. Close door. If you smell gas STOP! Follow "B" in the above safety information. If you do not smell gas go to the next step.
5. Find pilot-located to the left under the front log. Turn the gas control knob counter-clockwise  to "PILOT". Push the gas control in fully and hold, keep knob depressed for about 30 seconds after the pilot is lit. Release knob. If pilot goes out, repeat steps 4 through 5.




**WARNING:** this gas valve has a lockout device, which will not allow the pilot burner to be relit until the thermocouple has cooled. If the knob does not pop up when released, stop and immediately call your service technician or gas supplier.

If the pilot does not stay lit after several tries, turn the gas control knob to "OFF" and call your service technician or gas supplier.

6. Turn the gas control knob counter clockwise  to the "ON" position. Flip the burner switch to "ON" THEN TURN THE "HI/LOW" knob to the desired setting.
7. Turn on the electrical power to the unit.



### TO TURN OFF GAS TO APPLIANCE

1. Flip burner switch to "OFF"
2. Turn the gas control knob clockwise  to the "OFF" position.
3. Turn off all electrical power to the appliance if service is to be performed.

C-10489

**Figure 3: Lighting instruction label.**

# OPERATING INSTRUCTIONS

## PILOT LIGHT:

1. Turn off the gas to the fireplace. **If not recently done, remove the glass and let the unit air out for at least five (5) minutes to clear out any gas.** Turn on gas to the heater. Leak test all joints with soapy water. **NEVER USE OPEN FLAME FOR LEAK TESTING.**
2. Start the pilot by pressing the gas control knob and turning it to PILOT. While holding the gas control knob in, press the piezo ignitor several times until the pilot light starts. Hold the gas control knob in for 30 seconds. Check that the pilot has fully engulfed the thermocouple assembly (see Figure 4).
3. Start the main burner by turning the gas control knob to ON and then turn the rocker switch to ON. Check that all burner ports have flame.
4. Leak test all gas joints again.

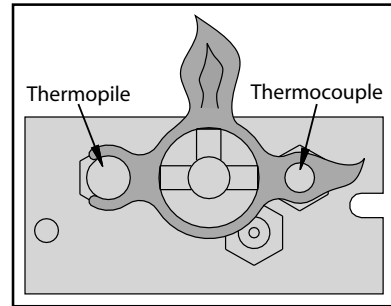


Figure 4. Pilot Flame

## VENTURI ADJUSTMENT:

The venturi adjustment lever is located on the right side of the unit, below the door (see Figure 5).

The venturi allows the amount of air coming into the fireplace to be adjusted in order to accommodate different climates and venting arrangements. Start the pilot and then the burner. Make sure the pilot flame is burning normally and none of the burner ports are plugged. Let the fireplace burn for roughly fifteen (15) minutes and then examine the flames.

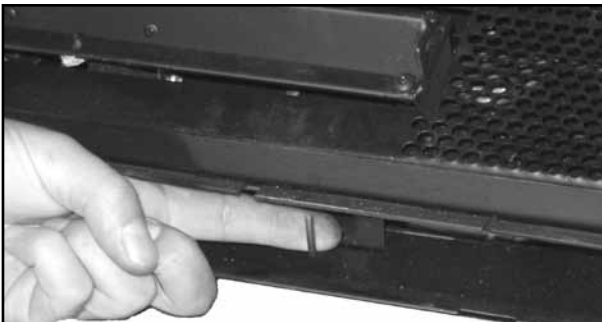


Figure 5: Adjusting the venturi air setting.

The ideal flame will be blue at the base and light orange above (see Figure 51). The flames should be of medium height. If the flames look like this, no venturi adjustment is needed. If the flames are fairly short and mostly blue, the fireplace is getting too much air. Therefore, the air shutter should be closed (push in) slightly until the correct flames are achieved. Flames that are very orange, with tall dark stringy tips are not getting enough air. Open (pull out) the venturi until the flames clean up. If the venturi is opened, then closed all the way, and the correct flames cannot be attained, turn off the gas and contact the dealer.

**Warning:** Incorrect venturi adjustment may lead to improper combustion, which is a safety hazard. Contact the dealer if there is any concern about the venturi adjustment.

## MAINTENANCE AND SERVICE - GLASS DOOR REMOVAL.

## NORMAL SOUNDS DURING OPERATION:

Component	Sound & Reason
E20	Creaking when heating up or cooling down.
Burner	Light pop or poof when turned off; this is more common with LP units.
Temperature Sensor	Clinking when it senses to turn the blower on or off.
Pilot Flame	Quiet whisper while the pilot flame in on.
Blower / Fan	Air movement that increases and decreases with the speed of the blower.
Gas Control Valve	Dull click when turning on or off, this is the valve opening and closing.

Table 2: Normal Sounds

# OPERATING INSTRUCTIONS

---

## BURNER LIGHTING:

---

- A) Make sure the pilot is lit.
- B) Turn gas control knob COUNTER CLOCKWISE to ON.
- C) Flip the burner switch to ON (Located on the top-left of the surround panel).
- D) Turn HI/LO knob to the desired flame height.
- E) Turn on all electrical power to the unit.

**NOTE:** Check that all burner holes are lit.

## TO TURN GAS FIREPLACE OFF

Flip the burner switch to OFF to turn off burner only.

If the fireplace is to be turned off for the season or for servicing, turn control knob to OFF, turn the gas shut off valve to OFF. DO NOT FORCE IT. If the unit is going to be serviced, turn off the electrical power to the unit as well.

**NOTE:** When the unit is turned on for the first time, it should be turned onto high, with the fan OFF, for the first four (4) hours. This will cure the paint, logs, gasket material, and other products used in the manufacturing process. It is advised that a door or window be opened as the unit will start to smoke, which can irritate some people. After the unit has gone through the first burn, turn the unit OFF, including the pilot, and let the unit completely cool. Then remove the glass and clean it with a good gas fireplace glass cleaner, available at your local Enviro dealer. See MAINTENANCE AND SERVICE - CLEANING THE GLASS and



**Figure 6: E20 Control Panel.**

## BLOWER SPEED:

---

The blower will come on only when the fireplace is up to temperature (approximately 15 minutes). Rotating the fan controller knob on the unit's control panel will change the speed of the fan (refer to Figure 6).

# MAINTENANCE AND SERVICE

---

**Warning:** Failure to position the parts in accordance with this manual, or failure to use only parts specifically approved with this appliance, may result in property damage or personal injury.

At least once a year, run through the following procedures to ensure the system is clean and working properly. Check the burner to see if all the ports are clear and clean. Check the pilot to make sure it is not blocked by anything. The pilot flame should be blue with little or no yellow on the tips.

The venting system must be periodically examined; it is recommended the examination is done by a qualified agency.

## CLEANING THE GLASS:

---

**When the fireplace is cool**, remove the glass door. See MAINTENANCE AND SERVICE - GLASS DOOR REMOVAL. Check the gasket material on the back of the glass, making sure that it is attached and intact.

During a cold start up, condensation will sometimes form on the glass. This is a normal condition with all fireplaces. However, this condensation can allow dust and lint to cling to the glass surface. Initial paint curing of the appliance can leave a slight film behind the glass, a temporary problem. The glass will need cleaning after the fireplace has cooled off from the first burn and about two weeks after first burn. **Use a mild glass cleaner and a soft cloth. Abrasive cleaners will damage the glass and painted surfaces.** Depending on the amount of use, the glass should require cleaning no more than two or three times a season. **Do not clean the glass when it is hot.**

## CLEANING THE FIREBOX:

---

Remove the logs carefully, as they are very fragile. Gently remove all the embers and rock wool and place on a paper towel. Vacuum the bottom of the firebox thoroughly. Carefully clean any dust off the logs and remove any lint from the burner and pilot. At this time, inspect the burner pan for cracking or severe warping. If a problem is suspected, contact the dealer. Check the logs for deterioration or large amounts of soot; a small amount on the bottom side of the logs is normal. Replace the logs and embers as in the SECONDARY INSTALLATION - LOG SET AND EMBER INSTALLATION section. If new/more embers and rock wool are required, contact your nearest ENVIRO dealer.

## REPLACING THE GLASS:

---

The glass in the fireplace is a high temperature ceramic. If the glass is damaged in any way, a factory replacement is required (see PARTS LIST). Wear gloves when handling damaged glass door assembly to prevent personal injury. When the glass door assembly is being transported, it must be wrapped in newsprint and tape and/or a strong plastic bag. Do not operate with the glass front removed, cracked or broken. Removal and replacement of the glass from the door **must** be done by a licensed or qualified service person. **The glass must be purchased from an ENVIRO dealer. No substitute materials are allowed.**

## CHECK PILOT AND BURNER FLAMES:

---

Periodically do a visual check of the pilot flames. One flame should encompass the ignitor and thermocouple and the other should burn over the burner ports (see Figure 7). Also check that the burner is operating correctly, refer to Figure 51.

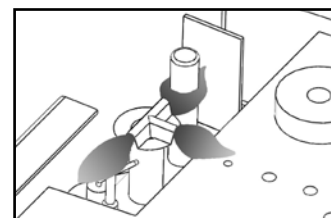


Figure 7: Pilot Flame

# MAINTENANCE AND SERVICE

---

## GLASS DOOR REMOVAL:

---

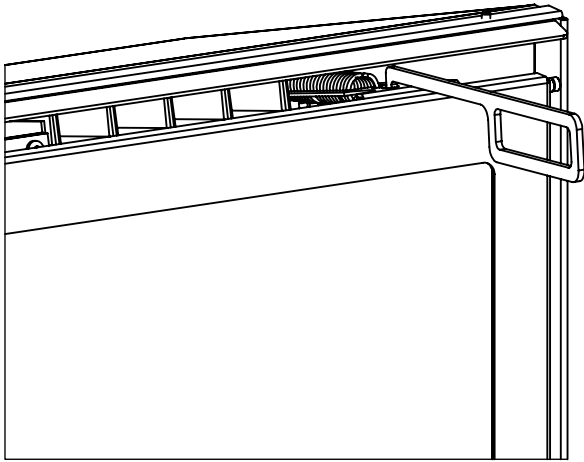


Figure 8: Door Release.

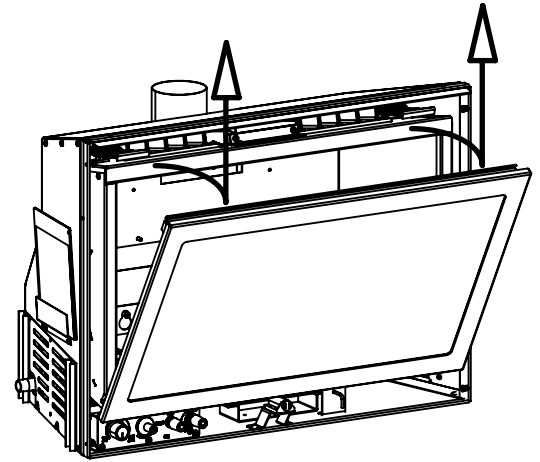


Figure 9: Door Removal.

Remove the glass door by placing the hooked end of the door release tool in the hole on the door latch mechanism (see Figure 8) and pulling the latch out then up over the lip on the door. When the two (2) latches have been released, tilt the door forward and then lift up to unhook the bottom door tabs (see Figure 9).

**Warning:** Do not touch or attempt to remove the glass if the fireplace is not completely cool.  
**Never operate the fireplace with the glass removed.**

CAUTION GLASS MAY SEPARATE FROM DOOR.

## CLEANING THE PAINTED SURFACES:

---

Painted faces should be periodically wiped with a damp cloth.

# MAINTENANCE AND SERVICE

## REMOVING VALVE COVER:

The valve cover can be removed to access the gas valve, the fan, wiring harness, or other components.

1. Remove the glass door as shown in the MAINTENANCE AND SERVICE - GLASS DOOR REMOVAL.
2. Carefully remove the log set, ember material, and brick panels, refer to SECONDARY INSTALLATION - BRICK PANEL INSTALLATION and SECONDARY INSTALLATION - LOG SET AND EMBER INSTALLATION.
3. Using a T-20 screwdriver remove the two (2) screws that hold the burner tray in place (pointed out in Figure 10). Pick up the burner tray at the front (see Figure 11) then pull it out of the firebox.
4. Using a T-20 screwdriver remove the six (6) screws that hold the valve cover in place (pointed out in Figure 12). Pick the valve cover up then out of the firebox (see Figure 13).



Figure 10: Screws Holding Burner Tray in Place.



Figure 11: Removing Burner Tray.

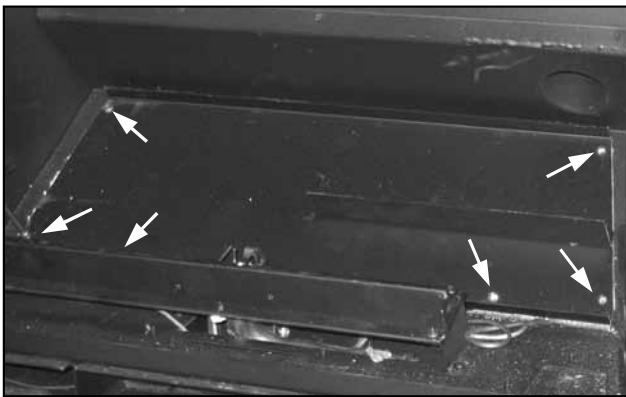


Figure 12: Screws Holding Valve Cover in Place.

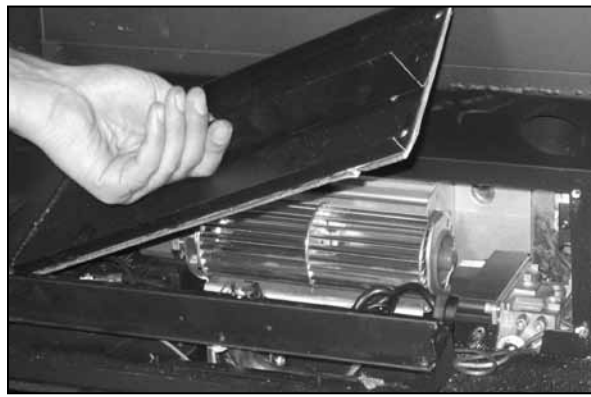


Figure 13: Removing Valve Cover.

## FUEL CONVERSION:

**TO BE INSTALLED BY A QUALIFIED SERVICE AGENCY ONLY**

**Please read and understand these instructions before installing.**

**Warning:** This conversion kit shall be installed by a qualified service agency in accordance with the manufacturer's instructions and all applicable codes and requirements of the authority having jurisdiction. If the information in these instructions is not followed exactly, a fire, explosion or production of carbon monoxide may result causing property damage, personal injury or loss of life. The qualified service agency is responsible for the proper installation of this kit. The installation is not proper or complete until the operation of the converted appliance is checked as specified in the manufacturer's instructions supplied with the kit.

# MAINTENANCE AND SERVICE

## Kit Parts List:

- 1 - Orifice (Natural Gas #44 DMS or Propane #55 DMS)
- 1 - Conversion label
- 1 - Installation instruction sheet

Carefully inspect the orifice supplied with this conversion kit. If it has been damaged or is missing, contact your dealer, distributor or courier company to have them replaced before starting this installation.

## Conversion Kit Installation:

1. Shut the gas supply off at the shut-off valve upstream of the unit. CAUTION: The gas supply must be shut off prior to disconnecting the electrical power and before proceeding with the conversion. Allow the valve and unit to cool down to room temperature.
2. Remove the glass door as shown in the MAINTENANCE AND SERVICE - GLASS DOOR REMOVAL.
3. Carefully remove the log set and ember material if they are installed.

4. Using a T-20 screwdriver, remove the four (4) screws that hold the burner in place (pointed out in Figure 14). Slide the burner to the left (see Figure 15), then up and out of the firebox.

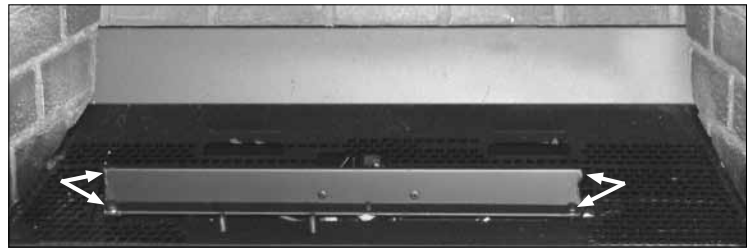


Figure 14: Unfastening Burner.

5. Convert the burner orifice:
  - a) Remove the main burner orifice with a 1/2 inch deep socket (see Figure 16).
  - b) Put a bead of pipe-thread sealant or approved Teflon tape on the orifice threads before installing into the brass elbow.
  - c) Install the new orifice from the kit into the steel adapter nut (see Figure 17).
6. Convert the pilot:
  - a) Using a 7/16" wrench, turn the pilot head a 1/4 turn counter-clockwise (shown in Figure 18).
  - b) Push the slider, with your finger or flat head screwdriver, to the left if it is to be set for natural gas or to the right for propane, red on the slider will be visible (see Figure 19).
  - c) Turn the pilot head a 1/4 turn clockwise; back to its original position.

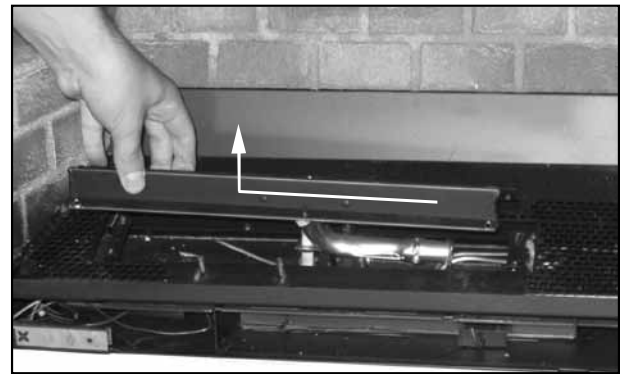


Figure 15: Burner Removal.



Figure 16: Orifice Removal.

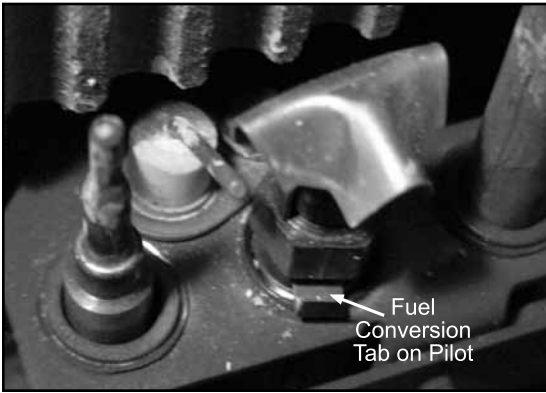


Figure 17: Orifice Replacement.



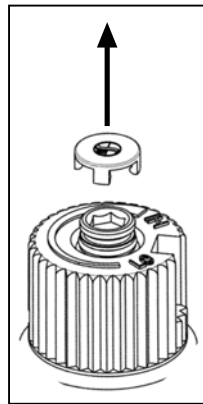
Figure 18: Turn Pilot Head.

# MAINTENANCE AND SERVICE

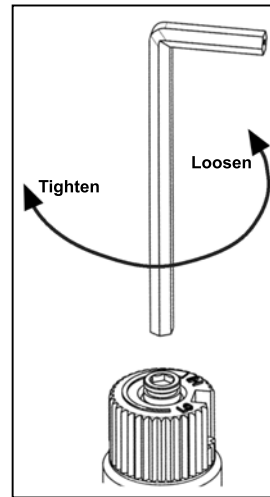


**Figure 19: Fuel Conversion Tab on Pilot.**

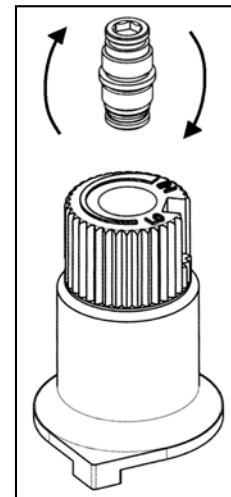
7. Convert the SIT gas valve:
  - a) Remove the extension knobs from the valve.
  - b) Remove the black protection cap from the HI/LO knob by hand shown in Figure 20.
  - c) Insert a  $\frac{5}{32}$ " or 4 mm Allen wrench into the hexagonal key-way of the screw (see Figure 21), rotate it counter-clockwise until it is free and extract it.
  - d) Check that the screw is clean and if necessary remove dirt.



**Figure 20: Removing valve cap.**

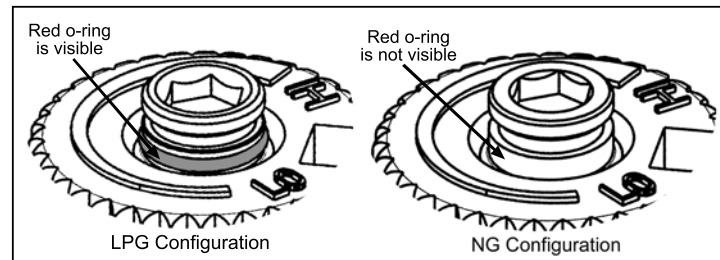


**Figure 21: Removing valve screw.**



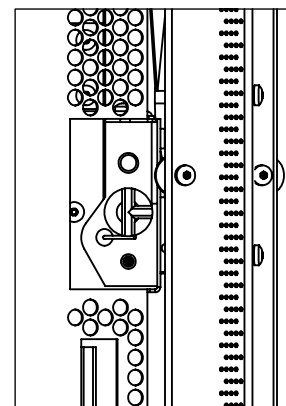
**Figure 22: Flip valve screw.**

- e) Flip the screw (refer to Figure 22).
  - f) Using the Allen wrench as shown in Figure 21, rotate the screw clockwise until a torque of 9 inch lbs. **WARNING!** Do not over tighten the screw. It is recommended that you grip the wrench by the short side.
  - g) Verify that if the conversion is from NG to LPG, the screw must be re-assembled with the red o-ring visible (refer to Figure 23). If the conversion is from LPG to NG, the red o-ring of the screw must be not visible.
  - h) Re-attach the black protection cap that was removed in step a (Figure 20).
8. Re-install the burner, ceramic panels, log set and glass door. Also refer to SECONDARY INSTALLATION - LOG SET INSTALLATION. When re-installing the burner, ensure that the burner to pilot hood relationship is similar to what is shown in Figure 24.



**Figure 23: O-ring on valve screw.**

9. Reconnect the main gas line if it was disconnected and open the shut-off valve at the gas line to the unit.
10. Use a small brush to apply a warm soapy water solution to all gas connections (use a half dish soap and half warm water). If a gas leak is present, bubbling will occur. Gas leaks can be repaired by using an approved pipe thread sealant or approved Teflon tape. NEVER USE AN OPEN FLAME WHEN TESTING FOR LEAKS.
11. Reconnect the electrical power to the unit.
12. Relight the main burner in both the "HI" and "LO" positions to verify proper burner ignition and operation and proper flame appearance (refer to Figure 51 or the Front Cover). Also refer to SECONDARY INSTALLATION - LOG SET INSTALLATION for a flame appearance picture.
13. MAKE SURE that the conversion label is installed on or close to the rating label to signify that the unit has been converted to a different fuel type.



**Figure 24. Pilot assembly beside the burner**

# INITIAL INSTALLATION

**WARNING:** Operation of this heater when not connected to a properly installed and maintained venting system can result in carbon monoxide (CO) poisoning and possible death.

## CLEARANCES TO COMBUSTIBLES:

Maintain sufficient clearances for operation, service and maintenance.

- A clearance of 7½" (191 mm) minimum is required from the side of the unit to the sidewalls.
- A clearance of 4½" (114 mm) minimum is required from the side of the unit to a 6" (152 mm) deep post/column.
- Minimum clearance for any ¾" combustible facing is 37½" (953mm) from the bottom of the unit.
- A 3 ½" (89 mm) wide mantel can be mounted at a minimum height of 37½" (953 mm) from the bottom of unit.
- A 10" (254 mm) wide mantel can be mounted at a minimum height of 38 ¼" (972 mm) from the bottom of unit.
- A 12" (305 mm) wide mantel can be mounted at a minimum height of 39 ¾" (1010 mm) from the bottom of unit.
- A non-combustible material must be installed under the unit.
- If installed at floor level, a minimum 13" (330 mm) non-combustible material must be installed in front of the unit.

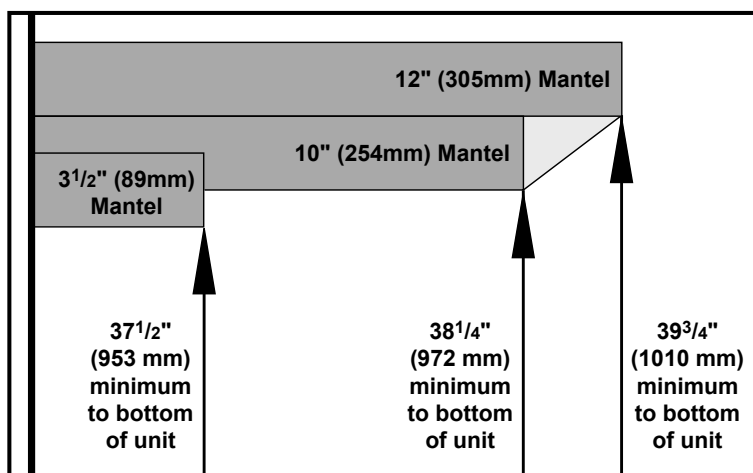


Figure 25: Mantle width and height.

## MINIMUM FIREPLACE SIZE:

Table 3: Minimum dimensions of fireplace for E20 to be installed into.

	Width At Front	Width At Back	Height	Depth
Fireplace Dimensions	24 ¼" (616 mm)	18 ⅛" (460 mm)	18 ¾" (462 mm)	14" (355 mm)

## DIRECT VENT:

**WARNING:** This appliance has been designed to draw room air for proper heat circulation from the sides and bottom of the unit, and out the top front. Blocking or modifying these openings in any way can create hazardous situations.

The vent height for the E20 must be between 10ft (3.05) and 35ft (10.67m).

This model is vented with a 2" intake and a 3" exhaust aluminum or stainless steel flex vent leading into a co-linear to co-axial vent adaptor and using a vertical termination cap. The flue collars of this model will fit inside of a standard 2" or 3" vent and may be fastened directly to the vent. The exhaust vent is on the top of the flue connector. The air intake is on the angled back of the vent collar plate. The air intake can be increased to a standard 3" size using Adaptor (50-1499 - 2" to 3" Air Intake) included with this unit.

Check periodically that the vents are unrestricted. Also ensure that all direct vent pipes have been properly sealed and installed after routine inspection or cleaning. The air intake and exhaust pipes must be installed in the correct locations on the back of the E20.

# INITIAL INSTALLATION

## QUALIFIED INSTALLERS ONLY

### PREPARING YOUR E20 FOR INSTALLATION:

- Remove the packaging from the appliance and surround panels; check to make sure there is no damage. Carefully check the glass door. Do not use the unit if it is damaged. In the event damage is found, please report it to both the courier and your dealer as soon as possible.
- Carefully clean the fireplace and flue before installing the stove. Failure to do so may result in fumes or dirt being blown into the room and may cause a fire leading to death or serious injury.

1. Remove the unit from the box and remove all packaging material from the appliance.
2. Remove door. See MAINTENANCE AND SERVICE - GLASS DOOR REMOVAL.
3. Remove log and ember set and all wrapping material from the stove. Remove wrapping material from log and embers and check for any damage. If damage is observed, do not use unit and contact your local dealer.
4. Check that the chimney clean outs fit properly. The flue damper must be fully blocked open or removed for installation of the E20; the smoke shelves, shields and baffles may be removed if attached by mechanical fasteners. **IMPORTANT:** Cutting any sheet-metal parts of a fireplace, in which the gas fireplace insert is to be installed is prohibited.
5. If the fireplace opening is lower than 20" (483mm), remove the vent collar plate from the top of the insert by unscrewing the two (2) T-20 Torx screws located on the center top of the stove above the door opening (see Figure 26). Slide the collar plate backwards. Properly secure the vent collar plate to the flexible vent pipe liner(s) previously installed in the chimney. Be careful not to over-stretch the liner(s).
6. Place the unit part way into the fireplace. Connect the household gas line into the  $\frac{3}{8}$ " NPT receptacle at the lower left rear of the unit using locally approved methods (see INITIAL INSTALLATION - GAS LINE CONNECTION). Place the electric cable so it can be connected to the power supply.
7. As you push the unit into its final position in the fireplace, if the vent collar plate was removed, reinstall it to the stove by sliding it along the draft hood and secure with the screws previously removed.
8. Using a T20 driver, adjust the levelling legs to ensure the unit is level and high enough if a base shelf and/or riser is to be installed. There are two (2) levelling legs on each side (shown in Figure 27).

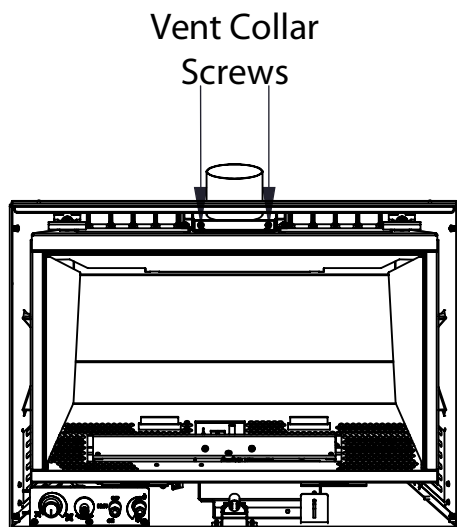


Figure 26: Vent Collar Plate Screw Location.

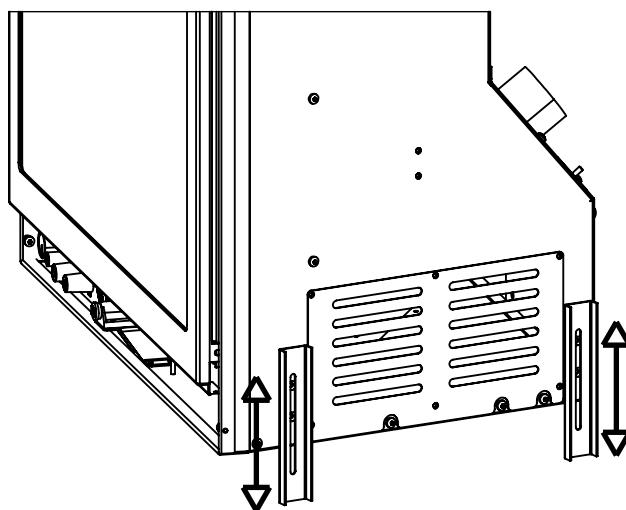


Figure 27: Levelling legs position.

# INITIAL INSTALLATION

## QUALIFIED INSTALLERS ONLY

### VENTING FIREPLACE INSERTS:

The **ENVIRO** E20 may be installed and vented into any solid fuel fireplace that has been installed in accordance with the National, Provincial/State and local building codes and has been constructed of non-combustible materials. Before starting, refer to INITIAL INSTALLATION - PREPARING YOUR E20 FOR INSTALLATION. Please reference the information in Table 4 and Figures 28, and 31.

An approved chimney liner and rain cap must be used. A throat connector or flashing **must** be installed to ensure a tight seal, top performance, safety and efficiency. Carefully follow the manufacturer's instructions that accompany the chimney liner kit. Use Flexmaster double walled aluminum flex vent (3" flex conversion piece and 4"x 6 5/8" cap) from any of the following approved products; American Metal Products (Amerivent Direct), Security Chimneys (Secure Vent), Selkirk Metalbestos (Direct-Temp), Simpson Dura-Vent (Direct Vent GS), and (ICC Excel Direct). If necessary, remove the vent collar plate from the top of the insert and connect it securely to the liner with sheet metal screws and/or hose clamps.

Check for any tears in the liner at this point. **IMPORTANT:** The screws that hold the vent collar plate in its

approved position must be installed.

Provide for proper and adequate venting and air supply for this appliance in accordance with the tables in the current National Fuel Gas Code, Z223.1/NFPA 54 or the CSA B149.1.

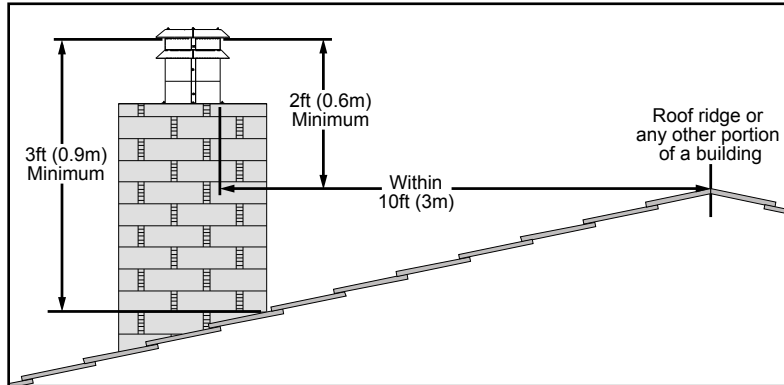
**NOTE:** If the E20 unit is pulled out of its installation, and the vent air intake system is disconnected for any reason, ensure that the vent-air intake pipes are re-sealed with high-temperature sealant or silicone and reconnected with three (3) sheet metal screws evenly spaced.

**Table 4: Vent termination clearances**

Minimum Clearance	Description
3 ft (0.9 m)	Clearance above the highest point where it passes through a roof surface, refer to Figure 28.
24 in (0.6 m)	Clearance above a roof ridge, any other portion of a building, or any other obstruction within a horizontal distance of 10 feet (3 m), refer to Figure 28.
5 ft (1.5 m)	Clearance for a vent or chimney above either the highest connected appliance draft hood outlet, or flue collar.
6 ft (1.83 m)	Clearance to mechanical air supply inlet.
3ft (0.9m)	Clearance to each side of center line extended above meter/regulator assembly.
6 ft (1.83 m)	Radial clearance around service regulator vent outlet.
12 in (30 cm)	Clearance above grade, verandah, porch, deck, or balcony.
3 ft (0.9 m)	Clearance to a building opening or combustion air inlet of another appliance, except with the approval of the authority having jurisdiction for the following reduced clearances.
9 in (0.23 m)	Exception for inputs up to and including 50,000 Btu/h (15kW)
12 in (0.3 m)	Exception for inputs exceeding 50,000 Btu/h (15kW) but not exceeding 100,000 Btu/h (30kW)

# INITIAL INSTALLATION

## QUALIFIED INSTALLERS ONLY



**Figure 28: Roof Clearances.**

# INITIAL INSTALLATION

## QUALIFIED INSTALLERS ONLY

### DIRECT VENT VERTICAL VENT TERMINATION:

**For use with E20 Direct Vent Fireplace Insert.** The Vertical Vent Cap is termination, rain cap, and a throat connector, it will ensure a tight seal, top performance, safety and efficiency.

### KIT COMPONENTS:

Quantity	Description	Quantity	Description
1	Vertical Direct Vent Termination Cap	1	4 oz Tube RTV Silicone
6	9/16" Tex Screws	1	4 oz Tube Mill-Pac Sealant

Please ensure that all components are supplied with this kit. If components are missing or have been damaged, contact your dealer, distributor, or courier company. Do not attempt the installation if components are missing or damaged.

### INSTALLATION INSTRUCTIONS:

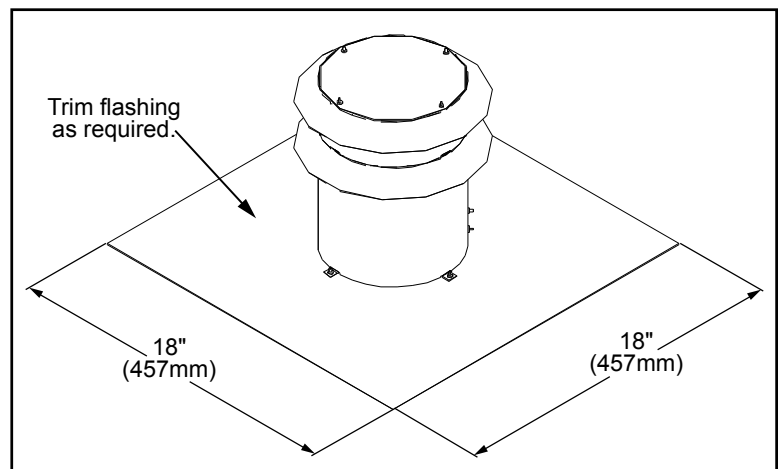
1. Plan your installation and clearances to combustibles. The E20 may be installed and vented into any solid fuel fireplace that has been installed in accordance with the National, Provincial/State and local building codes and has been constructed of non-combustible materials. Also refer to the INITIAL INSTALLATION - PREPARING YOUR E20 FOR INSTALLATION and CLEARANCES TO COMBUSTIBLES sections. Refer to Figure 31 throughout installation.
2. Stretch both the Ø3" (76mm) flex vent and the Ø2" (51mm) flex intake liner to the length needed to ensure the flex can be easily connected to the vent terminal.
3. Install the flex pipe assembly up through the chimney, ensure that the pipe slides through far enough to connect onto the Vertical Vent Cap.

**Note:** For any chimney over 15' (4.6m), install the E20 15' 2" & 3" Flex Vent (part #50-1512) and the E20 2" & 3" Flex Couplers (part #50-1513). Place a bead of sealant on the coupler (Mill-Pac Black sealant for the Ø3" (76mm) and high temperature silicone for the Ø2" (51mm)) Slide the meeting ends of the flex over the coupler and fasten each joint in place with three (3) sheet metal screws through the flex and into the coupler.

4. The Vertical Vent Cap can be installed onto chimneys with flue openings up to 16" (406mm) x 16" (406mm) and the actual flashing is 18"x18" (refer to Figure 29). If the chimney is smaller the cap should be trimmed down and folded over.

5. Apply a bead of Mill-Pac Black sealant to the top section of the Ø3" (76mm) vent collar plate. Slide the Ø3" (76mm) flex vent over the flue collar and secure with three (3) sheet metal screws evenly spaced.

**Note:** If fireplace opening is lower than 19" (483mm), remove the vent collar plate from the top of the insert (see INITIAL INSTALLATION - PREPARING YOUR E20 FOR INSTALLATION) and connect it securely to the liner as stated in Step 4. Check for tears in the liner at this point.

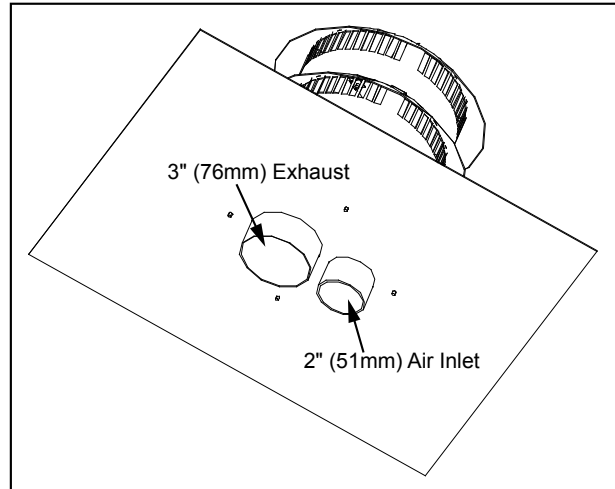


**Figure 29: Vertical Vent Cap Dimensions.**

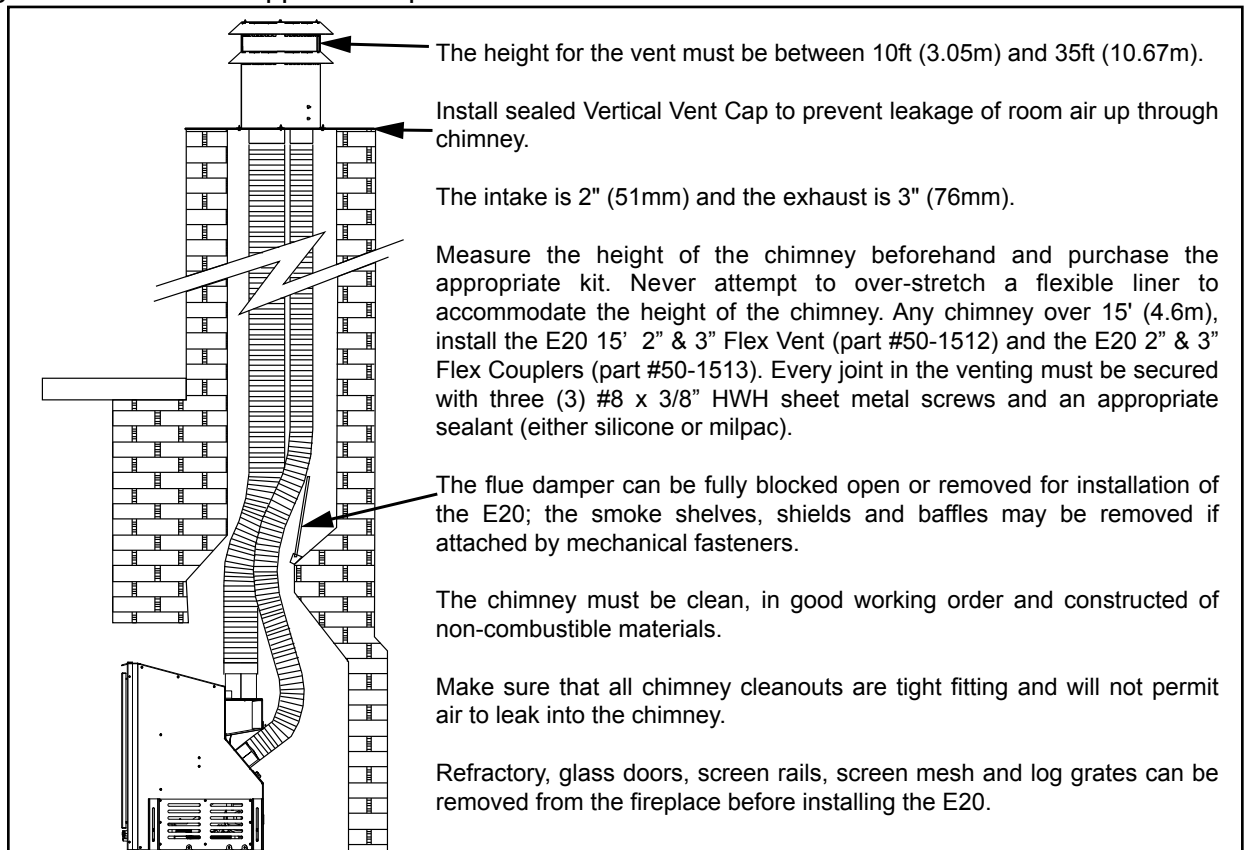
# INITIAL INSTALLATION

## QUALIFIED INSTALLERS ONLY

- Place a bead of high temperature silicone on the intake collar of the fireplace, slide the Ø2" (51mm) flex intake liner over the collar, secure the flex liner with three (3) sheet metal screws evenly spaced.
- At the top of the chimney, apply a bead of Mill-Pac Black sealant to the Ø3" (76mm) pipe of the vent terminal (refer to Figure 30). Slide the flex liner onto the vent terminal and secure with three (3) sheet metal screws evenly spaced.
- Place a bead of high temperature silicone on the intake collar of the vent terminal (refer to Figure 30). Slide the Ø2" (51mm) flex intake liner over the collar, secure the flex liner with three (3) sheet metal screws evenly spaced.
- Make a tight connection between the gas fireplace insert flue collar and the fireplace chimney at the top of the chimney. Secure the vent terminal to the chimney using adequate sealant, and according to local building codes.
- Light the E20 and ensure proper operation and proper flame appearance. The amount of air to the venturi may need to be adjusted using the rod under the firebox (see Figure 5). Also refer to Figure 51 for a flame appearance picture.



**Figure 30: Vertical Vent Cap Underside.**



**Figure 31: Installation of E20 DV .**

# INITIAL INSTALLATION

## QUALIFIED INSTALLERS ONLY

### ELECTRICAL REQUIREMENTS:

The fan will not operate if the appliance is cold. A few minutes after the appliance is lit and the fan is set to the desired level, the fan will automatically turn on. The fan will automatically turn off after the appliance has cooled down.

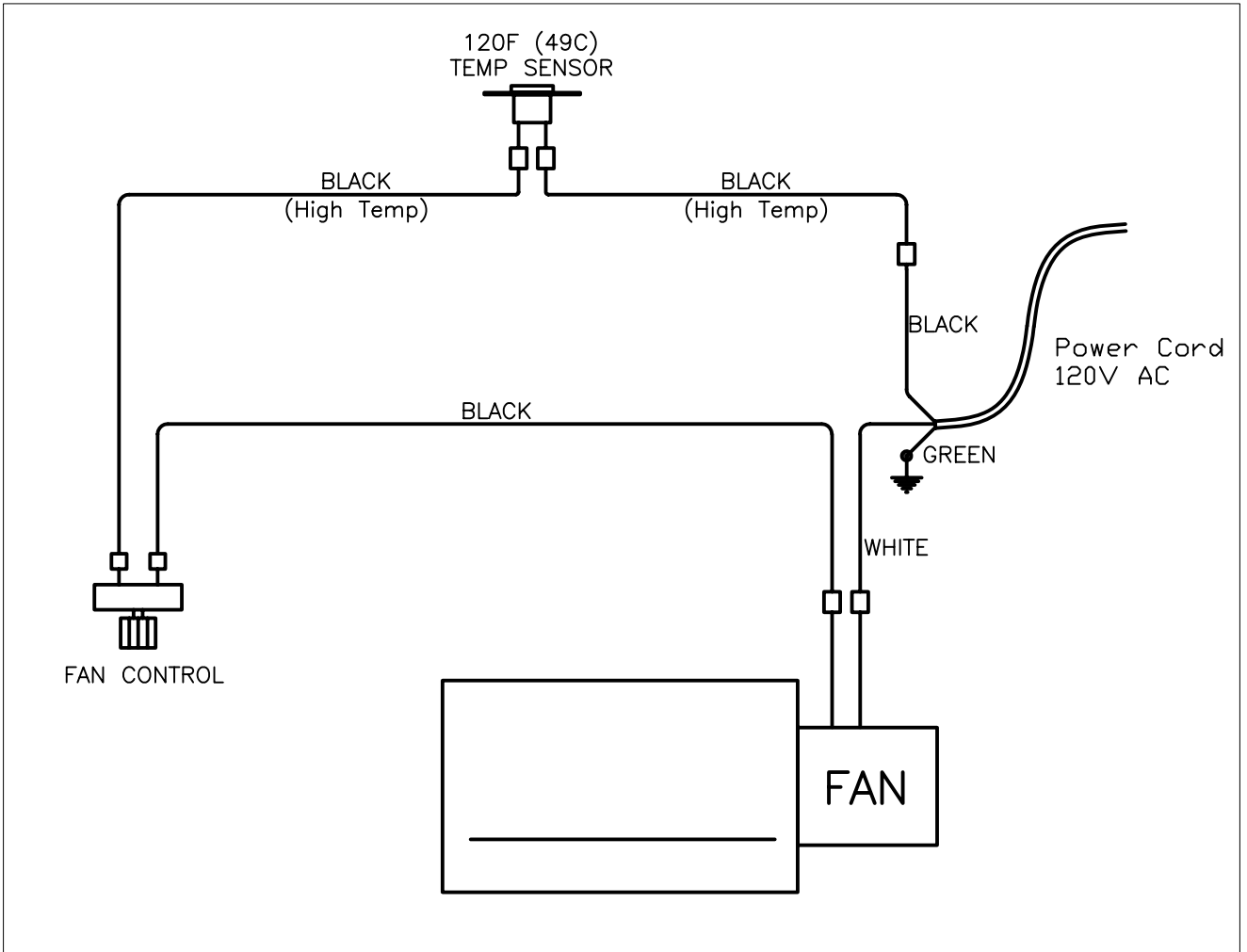


Figure 32: Fan wiring diagram.

The fireplace must be electrically connected and grounded in accordance with local codes or, in the absence of local codes, with the current CSA C22.1 Canadian Electrical Code Part 1, Safety Standards For Electrical Installations, or The National Electrical Code ANSI / NFPA 70 in the US.

**WARNING:** The electrical grounding instructions must be followed. The fan kit is equipped with a three-prong (grounding) plug for your protection against shock hazard, and should be plugged directly into a properly grounded three-prong outlet. DO NOT cut or remove the grounding prong from this plug.

**CAUTION:** When servicing controls, label all wires prior to disconnection. Wiring errors can cause improper and dangerous operation. Verify proper operation after servicing.

# INITIAL INSTALLATION

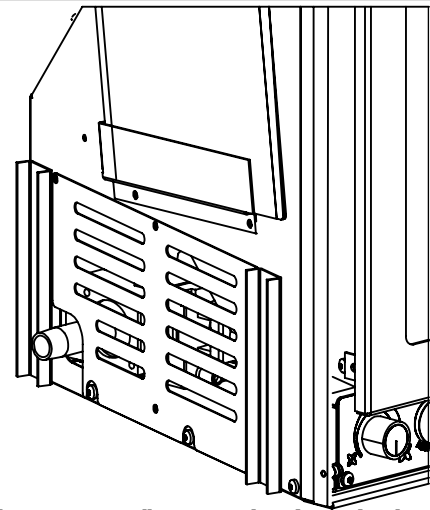
## QUALIFIED INSTALLERS ONLY

### GAS LINE CONNECTION:

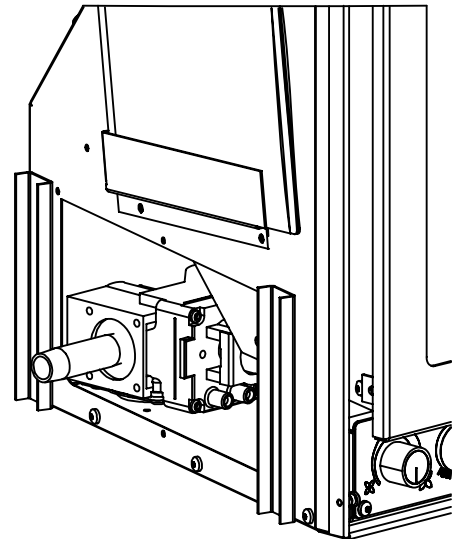
**Warning:** Only persons licensed to work with gas piping may make the necessary gas connections to this appliance.

#### **Gas Line Connection:**

- A 3/8" NPT male pipe nipple (supplied with the unit) will have to be turned into the valve at the lower left side rear of this fireplace (see Figures 33 and 34). Consult the local authorities for local codes or use the CAN/CGA B149 (1 or 2) installation code in Canada. In the US, gas installations follow either local codes or the current edition of the National Fuel Gas Code ANSI Z223.1.
- The efficiency of this unit is a product thermal efficiency rating determined under continuous operating conditions and was determined independently of any installed system.
- If the factory-built fireplace has no gas access hole(s) provided, an access hole of 1.5 in (37.5mm) or less may be drilled through the lower sides or bottom of the firebox in a proper workmanship like manner. This access hole must be plugged with non-combustible insulation after the gas supply line has been installed."
- A shut-off valve is not supplied with this unit but one should be installed.
- The appliance and its shut-off valves must be disconnected from the gas supply piping system during any pressure testing where the pressure **exceeds** 1/2 psig (3.45 KPa) or the valve will be damaged.
- The unit must be isolated from the gas supply piping system by closing its individual manual shut off valve during any pressure testing of the gas supply piping system at pressures **equal to or less than** 1/2 psig (3.45 KPa).



**Figure 33: 3/8" NPT Male Pipe Nipple with Cover Attached.**



**Figure 34: 3/8" NPT Male Pipe Nipple with Cover Removed.**

**Table 5: Orifice and Pressure Information.**

Main Burner	Natural Gas	Propane Gas
Orifice:	#44 DMS	#55 DMS
Manifold Press:	3.8 W.C. (0.95 KPa)	11.0 W.C. (2.74 KPa)
Min. Manifold Press:	1.2 W.C. (0.30 KPa)	2.7 W.C. (0.67 KPa)
Max. Supply Press:	7.0 W.C. (1.74 KPa)	13.0 W.C. (3.28 KPa)
Min. Supply Press:	5.0 W.C. (1.24 KPa)	12.0 W.C. (2.96 KPa)
Max. Input:	25,500 BTU/hr (6.59 KW)	21,300 BTU/hr (6.24 KW)
Min. Input:	12,500 BTU/hr (3.66 KW)	11,400 BTU/hr (3.34 KW)

# INITIAL INSTALLATION

## QUALIFIED INSTALLERS ONLY

### TO TEST VALVE PRESSURES:

The pressure taps are located on the front side of the valve (see Figure 35).

1. Follow steps 1-4 in REMOVING VALVE COVER - MAINTENANCE AND SERVICE. to access the valve.
2. Turn set screw one (1) turn counter-clockwise to loosen.
3. Place  $\frac{5}{16}$  in (8 mm) I.D. hose over the pressure taps.
4. Check pressures using a manometer.
5. When finished, release pressure, remove hose and tighten set screw.
6. Re-install the valve cover, burner tray, brick panels (refer to SECONDARY INSTALLATION - INSTALLING THE BRICK PANELS), log set and ember material (refer to SECONDARY INSTALLATION - LOG SET AND EMBER INSTALLATION) and the glass door.

**Always check for gas leaks with a soap and water solution after completing the required pressure test.**

## NEVER USE AN OPEN FLAME FOR LEAK TESTING.

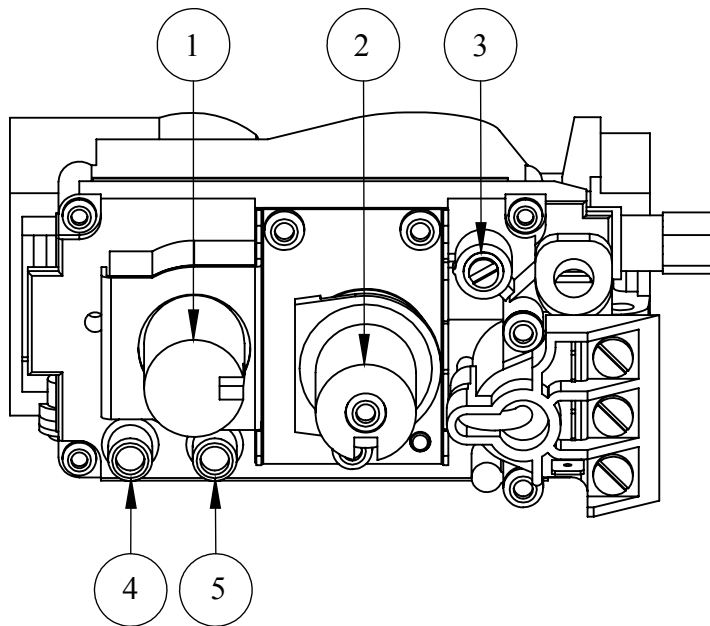


Figure 35: Valve Details.

Table 6: Valve Details.

ITEM NUMBER	DESCRIPTION
1	Control Knob (On/Off/Pilot)
2	Gas Flow Adjustment Knob
3	Pilot Adjustment Screw
4	Inlet Pressure Test Point
5	Outlet Pressure Test Point

# INITIAL INSTALLATION

## QUALIFIED INSTALLERS ONLY

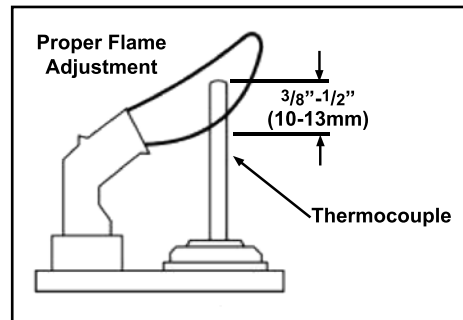
### ADJUSTING THE PILOT FLAME:

The pilot flow adjustment is pre-set to maximum at the factory and should not need to be adjusted. The pilot flame should envelope  $\frac{3}{8}$ " to  $\frac{1}{2}$ " (10 to 13mm) of the thermocouple (see Figure 36). However, should the need arise, follow Steps 1- 3 below.

- 1a. Follow steps 1-4 in REMOVING VALVE COVER - MAINTENANCE AND SERVICE in order to gain access to the valve from above. The pilot adjustment screw can be found in Figure 35.

OR

- 1b. The adjustment screw can be reached through the front of the unit using an eight inch flat head screw driver (see Figure 35 for location on valve).
2. Turn the adjustment screw clockwise to decrease or counterclockwise to increase pilot flame.
3. If valve cover was removed, re-install it.

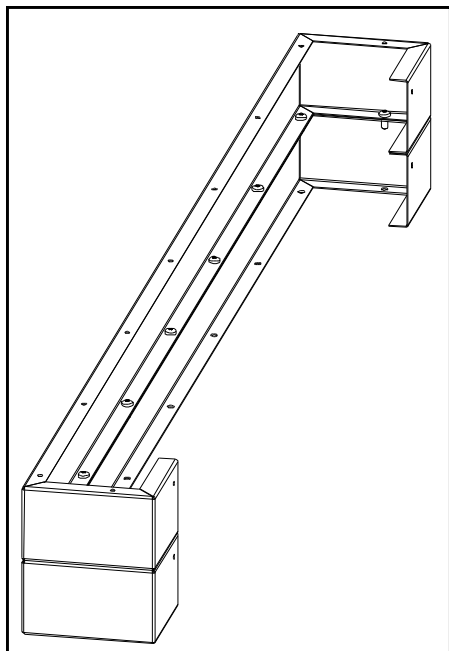


**Figure 36: Proper Pilot Flame.**

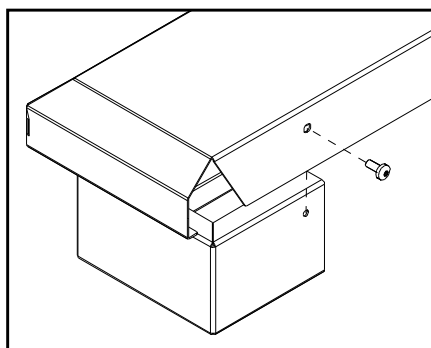
# SECONDARY INSTALLATION

## OPTIONAL BASE SHELF & RISER:

The E20 Base Shelf (1<sup>5</sup>/<sub>8</sub>" (41 mm) high) and Base Shelf Riser (2<sup>1</sup>/<sub>8</sub>" (54 mm) high) are components that can be combined to create a riser with an overall height of 2<sup>3</sup>/<sub>16</sub>" (55 mm). This shelf can be installed with or without the riser and can be used when the hearth in front of the unit is lower than the fireplace opening. Additional Base Shelf Risers can be fastened together to increase the height in increments of 2<sup>1</sup>/<sub>8</sub>" (54 mm). This Base Shelf may be used in conjunction with the any of the E20 surround panel options, and it may also be used with the E20 Trimmable Surround. The Base Shelf and Riser are sold separately.



**Figure 37: Combining 2 Base Shelf Riser.**



**Figure 38: Installing Base Shelf onto Riser.**

### Installation:

1. If unit is running, turn it off and allow it to cool completely.
2. When using more than one riser each level must be attached using nine (9) #8 T-20 screws provided (see Figure 37).
3. If installing with riser(s) the Base Shelf is to be fastened to the riser(s) with one T-20 screw at each end of the back (see Figure 38).
4. The leveling legs on the E20 may need to be adjusted to match the height of the riser and shelf. Each leveling leg has two (2) screws that can be loosened using a 1/4" hex driver (see Figure 27). Adjust the leg to the required height and then retighten the screws.
5. Center the Base Shelf assembly in front of the unit flush with the bottom of the unit.
6. Install surround if required.

# SECONDARY INSTALLATION

## SURROUND PANEL INSTALLATION:

**Warning:** The surround becomes hot when the unit is operating; ensure that the unit is turned off, and that it has cooled to room temperature before beginning this installation.

Height	Width
24" (610 mm)	35 3/8" (898 mm)

**Table 7: Surround Dimensions.**

Please check components supplied with this kit. If components are missing or have been damaged, contact your dealer, distributor or courier company before starting this installation.

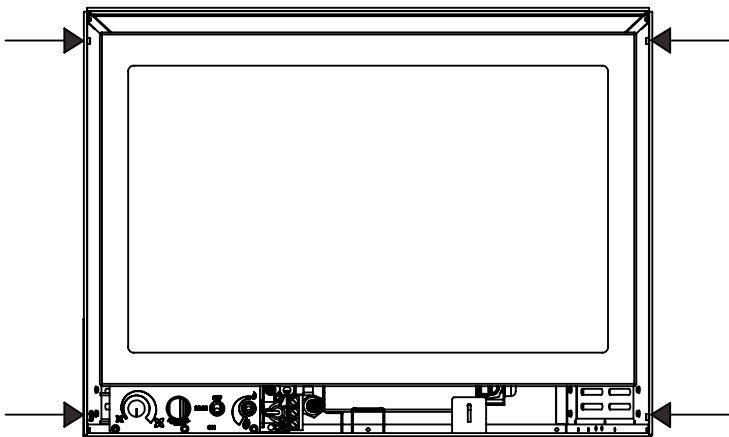
**IMPORTANT:** The panel must not seal ventilation openings in the fireplace.

## INSTALLATION:

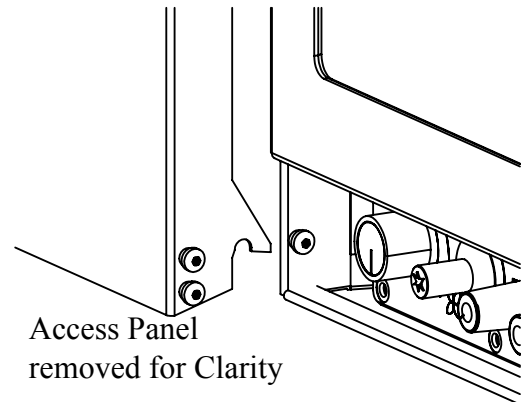
Lift the face upright in front of the fireplace with the four (4) hooks pointing towards the fireplace. Slide the hooks over their corresponding bushings (see Figures 39 & 40). Ensure the hooks are secure before releasing the surround. The surround should be wiped with a damp cloth periodically.

## REMOVAL:

Lift the surround straight up in order to unhook the notch on the hooks from the bushing. Pull the surround away from the fireplace. Place the surround where it will not be damaged.



**Figure 39: Bushing Locations.**



**Figure 40: Bushing and Hook Close-Up.**

## BURNER SWITCH WIRING INSTALLATION:

The burner switch supplied with the surround comes pre-installed and wired. The wiring from the burner switch simply needs to be connected to the wiring on the E20 unit.

The wiring harness for the burner switch has one (1) blue wire, one (1) grey wire and two (2) purple wires.

The blue wire connects to the blue wire on the E20 unit, the grey wire connects to the grey wire on the E20 unit, and the purple wires are used to connect an optional thermostat.

## CLEANING:

Painted surfaces should be periodically wiped with a damp cloth. **Never clean the face when it is hot.**

# SECONDARY INSTALLATION

## BRICK PANEL INSTALLATION:

**NOTE: The brick liner is fragile and should be handled gently.**

1. **Ensure the E20 is turned off and allow the unit to cool.**

2. Remove the glass door as shown in the MAINTENANCE AND SERVICE - GLASS DOOR REMOVAL.

**Warning:** Do not touch or attempt to remove the glass if the fireplace is not completely cool.

**Never operate the fireplace with the glass removed.**

3. Remove the log set and all ember material.

4. There is a ledge at the back of the firebox (see Figure 41). Place the back brick panel on the ledge and ensure the panel is flush at the bottom and top (refer to Figure 42). Do not push at the center of the panel.

5. Slide the front of the left brick panel into the left lip at the front of the firebox. Ensure the panel is flush to the side of the firebox and the back brick panel while still being hooked behind the front lip (refer to Figure 43). Take care to not bump the brick panel on the burner.

6. Repeat step 6 for right brick panel.

7. Install the log set and ember material (refer to SECONDARY INSTALLATION - LOG SET AND EMBER INSTALLATION) and the glass door.



Figure 41: Back Brick Panel Ledge.



Figure 42: Back Brick Panel in Place.



Figure 43: Side Brick Panels in Place.

# SECONDARY INSTALLATION

## LOG SET AND EMBER INSTALLATION:

**NOTE: The logs are fragile and should be handled gently.**

The placement of the logs is **not** arbitrary. If they are positioned incorrectly, the flames can be “pinched” and will not burn correctly. The burner and one of the logs come with locator pins and ledges, which make alignment easier. Using the pictures provided, carefully set the logs in place (see Figures 44 through 51).

Figure 44: The empty firebox showing the ledges for the back log.

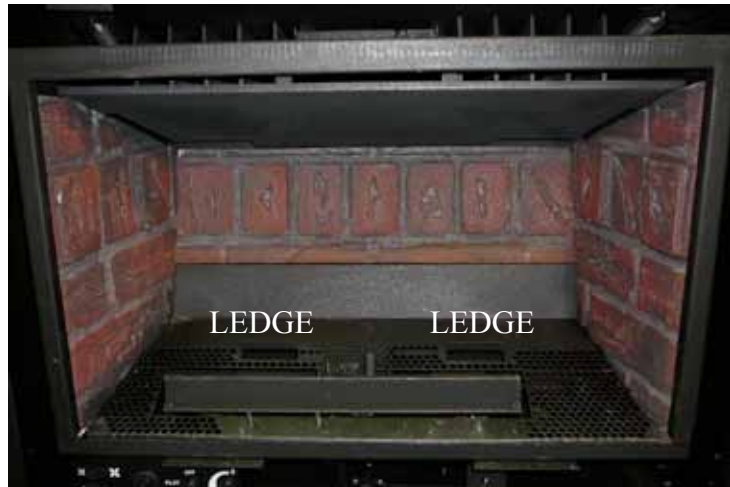


Figure 44. Empty firebox.



Figure 45. First Stage Log Set Installation.

Figure 45: The **back log** rests behind the two ledges pointed out in Figure 44. The front of the log rests at the end of the burner. Ensure it is flush against the left brick panel.



Figure 46. Second Stage Log Set Installation.

Figure 46: The **top left log** rests on the **back log** and utilizes the locator pin pointed out in Figure 45. Ensure it is flush against the left brick panel and against the back wall.

## SECONDARY INSTALLATION



Figure 47. Third Stage Log Set Installation.

Figure 47: The center of the **right log** fits against the **back log** (see Figure 46). The front of the log is to rest on the burner and the back end of the log rests on the back brick panel. Ensure the log does not block any burn ports.



Figure 48. Fourth Stage Log Set Installation.

Figure 48: The center of the **front log** fits onto the two (2) locator pins on the valve cover tray (see Figure 47).



Figure 49. Fifth Stage Log Set Installation.

Figure 49: Place the ember chunks and ember wool irregularly onto and around the front of the burner to create a realistic look. The ember wool comes in chunks that can be ripped into smaller pieces. The front log has been removed for clarity. See Figure 50 for complete log and ember set-up with the front log.

**WARNINGS:** DO NOT pack this ember material as this could create an unsafe condition. The pieces should be lightly placed so they don't block any of the burner ports.

DO NOT allow any of the embers to rest against the pilot assembly.

**Caution:** Use only the type of ember material supplied with this fireplace. Due to the irregular size of the ember material, there may be more than required. Use of other foreign materials on the burners may create dangerous conditions.

## SECONDARY INSTALLATION

---



**Figure 50. Log Set and Ember Installation.**



**Figure 51. E20 complete log set-up with embers burning.**

**NOTE:** While the glass is still removed, it is recommended that the gas line be purged by lighting the pilot.

When lighting the fireplace for the first time since the log set and embers have been installed/replaced, watch for ignition at ALL the burner ports. If a long delay is noticed, turn the appliance off and wait for it to cool down. Remove the glass and rearrange the ember material, making sure none of the burner ports air holes are blocked.

**Never operate the fireplace with the glass door removed.**

# TROUBLE SHOOTING

Problem	Possible Cause	Solution
The main burner does not ignite when called for.	The gas valve may not be on.	<ul style="list-style-type: none"> <li>• Check that the gas control knob is in the "ON" position.</li> </ul>
	Thermostat is not calling for heat.	<ul style="list-style-type: none"> <li>• Adjust the thermostat several degrees above ambient temperature.</li> </ul>
	Problem with gas valve.	<ul style="list-style-type: none"> <li>• Use a DC voltmeter to measure the voltage across the TPTH and TP terminals. Main operator voltage: Open circuit <math>\geq</math> 325mV Closed circuit <math>\geq</math> 100mV</li> <li>• If voltage is not present, check the control circuit for proper operation.</li> <li>• If proper control system voltage is present, replace the gas control.</li> </ul>
Spark will not light the pilot after repeatedly pressing the spark ignitor.	Defective piezo ignitor.	<ul style="list-style-type: none"> <li>• Check connections to ignitor.</li> <li>• If ignitor connections are good but no spark, replace ignitor.</li> </ul>
	Broken spark electrode.	<ul style="list-style-type: none"> <li>• Check for broken ceramic insulation, replace electrode if broken.</li> </ul>
	Misaligned spark electrode.	<ul style="list-style-type: none"> <li>• If spark is not arcing from electrode to pilot, loosen the screws on the pilot base adjust and tighten.</li> </ul>
Pilot will not remain lit.	Problem with thermocouple circuit.	<ul style="list-style-type: none"> <li>• Check for proper connection of the thermocouple to the rear of the valve. If loose, fully tighten.</li> <li>• Check pilot for full flame impingement around thermocouple. If flame is too small, check gas pressure, adjust pilot rate screw, check pilot head for damage.</li> <li>• Check thermocouple voltage at valve. It must be greater than 5 mV. If low, replace thermocouple.</li> </ul>
	Air in gas line (pilot dies while knob is depressed).	<ul style="list-style-type: none"> <li>• Bleed line.</li> <li>• Check gas line pressure.</li> <li>• Contact dealer.</li> </ul>
Burners will not remain lit.	Problem with thermopile circuit.	<ul style="list-style-type: none"> <li>• Check gas line pressure .</li> <li>• Check for flame impingement on thermopile. If low, see "Pilot will not remain lit".</li> <li>• Check thermopile for minimum of 300 mV when burner is switched on.</li> <li>• Check wiring to thermostat for breaks.</li> </ul>
Flame lifting	Leak in vent pipe	<ul style="list-style-type: none"> <li>• Check for leaks in vent connections.</li> </ul>
	Improper vent configuration	<ul style="list-style-type: none"> <li>• Check vent configuration with manual.</li> </ul>
	Terminal may be recirculating flue gases	<ul style="list-style-type: none"> <li>• Check to see if terminal is on correctly.</li> <li>• May need to install high wind termination cap.</li> <li>• Contact dealer.</li> </ul>
Glass fogs up	Normal Condition: after the appliance warms up the glass will clear. **Due to additives in gas, glass may get hazy during operation** Clean as needed.	
Blue Flames	Normal during start up: flames will yellow as the fireplace heats up.	
Flames are burning "dirty" or sooting	Flame impingement	<ul style="list-style-type: none"> <li>• Check log positioning.</li> <li>• Increase primary air by opening the venturi shutter and/or by opening the vent restrictor.</li> </ul> See also "Burners will not remain lit."
Remote control doesn't work	Problem with the remote	<ul style="list-style-type: none"> <li>• One or more of the batteries are dead. See remote control instructions.</li> </ul>
	Problem with fireplace	<ul style="list-style-type: none"> <li>• The on/off switch is turned to OFF.</li> <li>• The gas control valve is turned to PILOT or OFF.</li> <li>• The pilot has gone out.</li> </ul>

# PARTS LIST

---

Reference Number	Part Description	Part Number
1	E20 2" to 3" Air Intake Adaptor	50-1499
2	Flue Adapter Gasket	50-1490
-	E20 15' 2" & 3" Flex Vent	50-1512
-	E20 2" & 3" Flex Couplers	50-1513
-	E20 Vertical Vent Cap	50-1487
3	E20 Flue Adaptor and Bottom C/W Gasket	50-2351
4	E20 DV Flue Adaptor Bottom Gasket	50-1491
5	E20 Cabinet Back	50-2359
6	E20 Owners Manual	50-2261
7	E20 Conversion Kit NG to LP	50-2306
-	E20 Conversion Kit LP to NG	50-2307
8	Blank Orifice	50-343
9	E20 Door Release Tool	50-1500
10	Ember Nuggets Only	50-2347
11	Ceramic Wool Embers Only	50-893
12	Domestic Power Cord (115V)	EC-042
13	Heyco Strain Relief	EC-044
14	FPI Burner Switch	EC-026
15	E20 Pilot Shield	50-2350
16	E20 Valve Extension C/W Knob (Long)	50-2353
17	FPI Fan Controller (69.5V) 115V W/FS Knob	EC-039A
18	Fan Controller Knob W/Decal	EC-040
19	E20 Control Panel C/W Decal	50-2356
20	S.I.T. Piezo Ignitor	EC-023
21	E20 Control Panel Bushings (Set 2)	50-2352
22	E20 Control Panel Knobs (Set 2)	50-2355
23	E20 Burner Only	50-2358
24	E20 Door Complete	50-2348
25	E20 Glass C/W Gasket (21.75" X 13.575")	50-2349
26	Dual Bulb Door Gasket (10ft)	50-634
27	E20 Valve Cover with Gasket	50-1492
28	E20 Valve Extension C/W Knob (Short)	50-2354
29	E20 Burner Tray Only	50-2357
30	E20 Fan Only	50-2260

# PARTS LIST

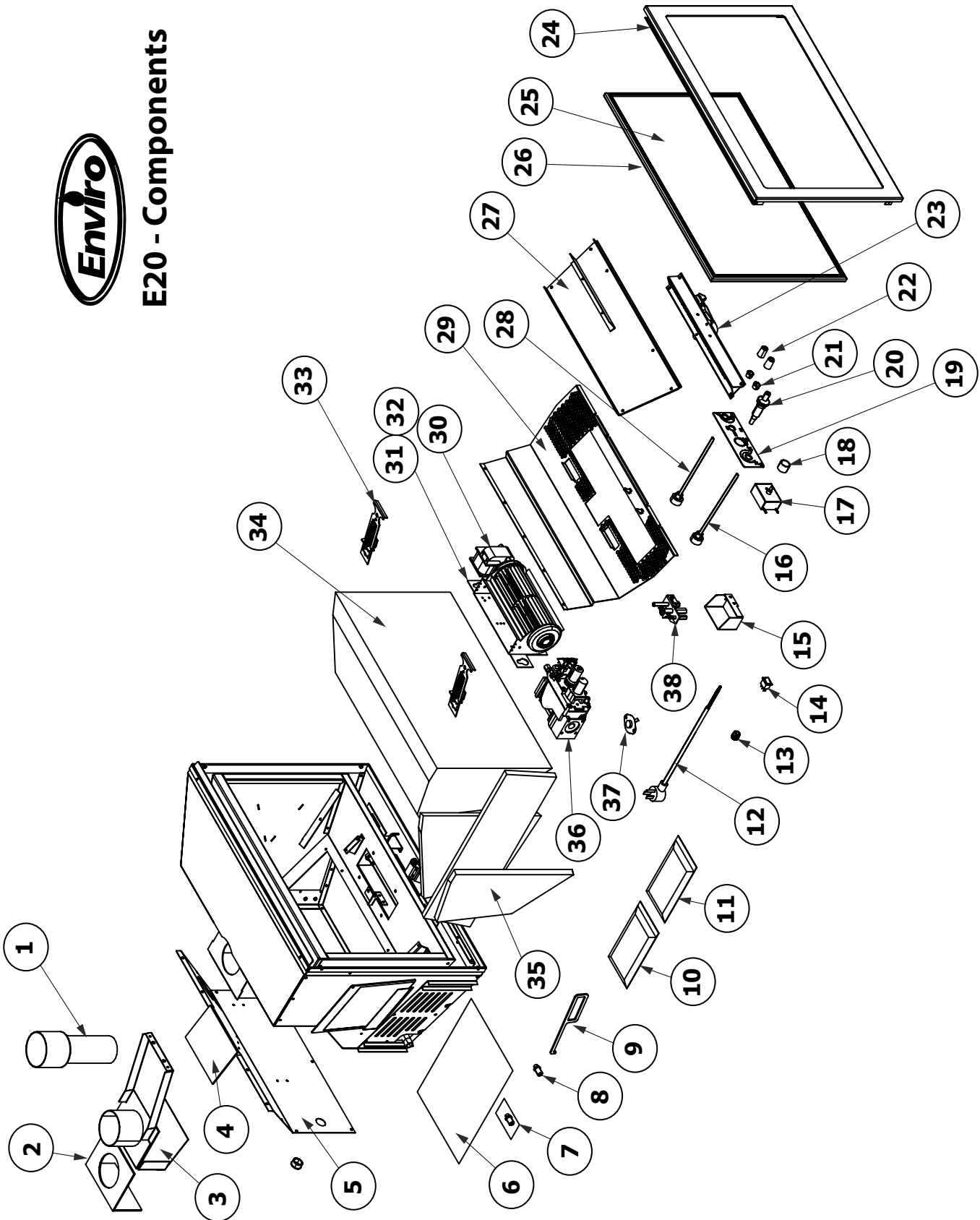
---

Reference Number	Part Description	Part Number
31	E20 Fan Mounting Bracket Only	50-1516
32	E20 Fan Assembly Complete	50-2346
33	E20 Door Latch Mechanism (Set of 2)	50-1495
34	E20 Logset (4 pcs)	50-2345
35	Rustic Red Brick Liner - E20	50-2256
36	S.I.T. Nova Valve Convertible	50-1421
37	120 Ceramic Fan Temp Sensor (All Models)	EC-001
38	E20/Cara PSE Pilot Assembly (PSE-C3-505)	50-1605
-	PSE Thermocouple Wires (Set 2)	50-1536
-	PSE Thermocouple (#019G)	50-1612
-	12 oz. Can of Metallic Black Touch Up Paint	PAINT-12-MB
Reference Number	Option Description	Part Number
39	Trim-able Surround Panel - E20	50-2255
40	Regular Surround Panel - E20	50-2250
41	Contemporary Surround Panel - E20	50-2252
42	Extruded Surround Panel - E20	50-2253
43	Base Shelf - E20	50-2258
44	Riser Shelf - E20	50-2344

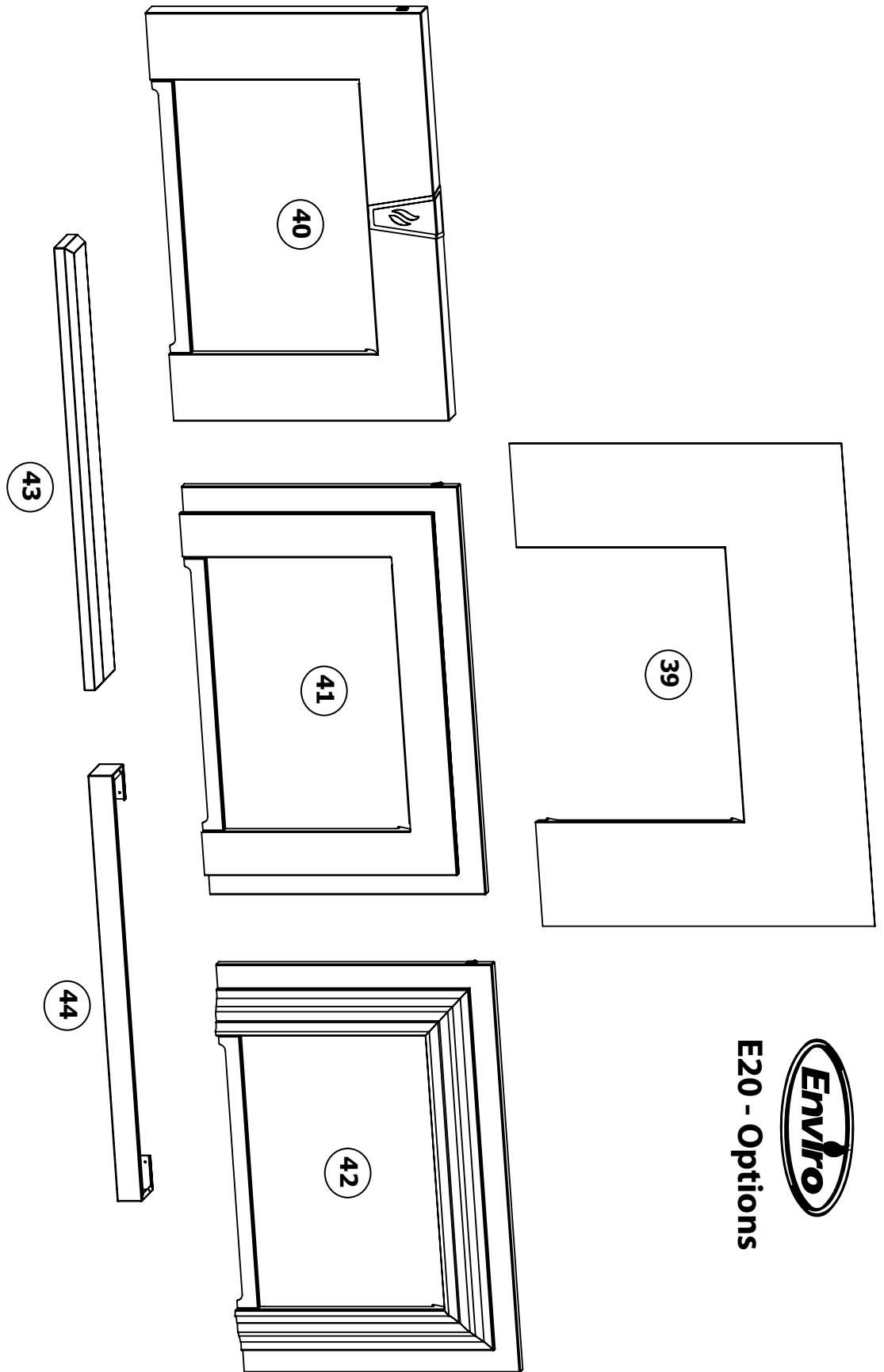
# PARTS DIAGRAM - COMPONENTS



## E20 - Components



# PARTS DIAGRAM - OPTIONS



E20 - Options

# WARRANTY

---

Sherwood Industries Ltd. is the manufacturer of the Enviro line of heating products. At Sherwood Industries, our commitment to the highest level of quality and customer service is the most important thing we do. Each Enviro stove is built on a tradition of using only the finest materials and is backed by our Exclusive Lifetime Limited Warranty to the original purchaser. With Enviro, you're not just buying a fireplace or stove, you're buying a company with years of unequalled performance and quality.

## **Limited Lifetime Warranty:**

Under this warranty, Sherwood Industries Ltd. covers the fireplace or stove body and accessories against defects in materials and workmanship, for part repair or replacement for the first seven (7) years and limited labour for the first two (2) years to the original purchaser. This Warranty covers: Firebox, Heat Exchanger, Steel Firebox Panels, Ceramic Logs & Panels, Burner, Ceramic Glass, Pedestals, Panels and Legs. Please see the exclusions and limitation section below as certain restrictions and exclusions apply to this warranty.

## **Limited Two (2) Year Warranty:**

Under this warranty, Sherwood Industries Ltd. covers: Gas Assembly, Blower, Blower control, Temperature Sensors and Wire Harness against defects in materials and workmanship, for part repair or replacement for the first two (2) years and limited labour for the first two (2) years to the original purchaser. Please see the exclusions and limitation section below as certain restrictions and exclusions apply to this warranty.

## **Limited One (1) Year Warranty:**

Under this warranty, Sherwood Industries Ltd. covers all exterior surface finishes against defects in materials and workmanship, for part repair or replacement and limited labour for the first (1) year to the original purchaser. Please see the exclusions and limitations section below as certain restrictions and exclusions apply to this warranty.

Here is how our Warranty works

If you have any concerns with your Enviro product, please contact the dealer where you purchased the fireplace or stove. Your dealer shall make all claims under this warranty in writing.

## **To the Dealer**

When filling out a warranty claim, please complete the following information on an official warranty claim form:

Customer information: Name, address and telephone number of purchaser and date of purchase.

Dealer information: Date of installation, name of installer and dealer, serial number of the appliance, nature of complaint, defects or malfunction, description and part numbers of any parts replaced.

## **To the Distributor**

Sign and verify that work and information are correct.

## **Exclusions and Limitations:**

1. This Warranty does not cover tarnish, discoloration or wear on the plating or paint.
2. This Warranty excludes wear and tear or breakage caused by cleaning, moving or service on log set and panels.
3. A qualified installer must install this stove or fireplace. This Limited Warranty covers defects in materials and workmanship only if the product has been installed in accordance with local building and fire codes; in their absence, refer to the owner's manual. If the product is damaged or broken as a result of any alteration, willful abuse, mishandling, accident, neglect, or misuse of the product, the Limited Warranty does not apply.

# WARRANTY

---

4. The stove must be operated and maintained at all times in accordance with the instructions in the Owner's Manual. If the unit shows signs of neglect or misuse, it is not covered under the terms of this Warranty policy. Performance problems due to operator error will not be covered by the Limited Warranty policy.
5. As this is a heating appliance, some changes in colour of surface finishes may occur. This is not a flaw and as such is not covered under this warranty.
6. Some minor expansion, contraction, or movement of certain parts and resulting noise, is normal and not a defect and, therefore, is not covered under this Limited Warranty.
7. Misuse includes over-firing. Over-firing this appliance can cause serious damage and will nullify the Limited Warranty.
8. The Limited Warranty will cover glass thermal breakage only and will not cover misuse of the stove glass, including but not limited to glass that is struck, has surface contaminates or has had harsh or abrasive cleaners used on it.
9. This warranty does not cover products made or provided by other manufacturers and used in conjunction with the operation of this stove without prior authorization from Sherwood Industries Ltd. The use of such products may nullify the Limited Warranty on this stove. If unsure as to the extent of this Limited Warranty, contact your authorized Enviro dealer before installation.
10. Sherwood Industries Ltd. will not be responsible for inadequate performance caused by environmental conditions.
11. The Limited Warranty does not cover installation and operational related problems such as use of downdrafts or spillage caused by environmental conditions. Environmental conditions include but are not limited to nearby trees, buildings, roof tops, wind, hills, mountains, inadequate venting or ventilation, excessive offsets, negative air pressures or other influences caused by mechanical systems such as furnaces, fans, clothes dryers etc.
12. The Limited Warranty is void if:
  - a) The stove has been operated in atmospheres contaminated by chlorine, fluorine or other damaging chemicals.
  - b) The stove is subject to submersion in water or prolonged periods of dampness or condensation.
  - c) Any damage to the unit, combustion chamber or other components due to water, or weather damage which is the result of, but not limited to, improper chimney/venting installation.
  - c) Salt air in coastal areas or high humidity can be corrosive to the finish; these environments can cause rusting. Damage caused by salt air or high humidity is not covered by the Limited Warranty.
13. Exclusions to the Limited Warranty include: injury, loss of use, damage, failure to function due to accident, negligence, misuse, improper installation, alteration or adjustment of the manufacturer's settings of components, lack of proper and regular maintenance, alteration, or act of God.
14. The Limited Warranty does not cover damage caused to the fireplace or stove while in transit. If this occurs, do not operate the stove and contact your courier and/or dealer.
15. Limited Warranty does not extend to or include firebox paint, door or glass gaskets with damage caused by normal wear and tear, or exterior paint discoloration or chipping, worn gaskets, etc.
16. The Limited Warranty does not include damage to the unit caused by abuse, improper installation, or modification of the unit.
17. Damage to plated surfaces caused by fingerprints, scratches, melted items, or other external scores and residues left on the plated surfaces from the use of abrasive cleaners or polishes is not covered in this warranty.
18. The Limited Warranty does not cover tarnish, discoloration or wear on the plated surfaces.
19. The paint on the Metal Brick Liner may peel. This is due to the extreme conditions applied to the paint during normal usage. It is not a flaw and is not covered under warranty.

# WARRANTY

---

20. Sherwood Industries Ltd. is free of liability for any damages caused by the fireplace or stove, as well as inconvenience expenses and materials. The Limited Warranty does not cover incidental or consequential damages.
21. The Limited Warranty does not cover any loss or damage incurred by the use or removal of any component or apparatus to or from the Enviro fireplace or stove without the express written permission of Sherwood Industries Ltd. and bearing a Sherwood Industries Ltd. label of approval.
22. Any statement or representation of Enviro products and their performance contained in Enviro advertising, packaging literature, or printed material is not part of the Limited Warranty.
23. The Limited Warranty is automatically voided if the fireplace or stove's serial number has been removed or altered in any way. If the stove is used for commercial purposes, it is excluded from the Limited Warranty.
24. No dealer, distributor, or similar person has the authority to represent or warrant Enviro products beyond the terms contained within the Limited Warranty. Sherwood Industries Ltd. assumes no liability for such warranties or representations.
25. Sherwood Industries Ltd. will not cover the cost of the removal or re-installation of the stove, hearth, facing, mantels, venting or other components.
26. Labour to replace or repair items under this Limited Warranty will be covered per our warranty service fee reimbursement schedule. Labour rates are set per component and as such total labour costs may not be covered.
27. Sherwood Industries Ltd. is not liable for freight or labour on any stove replaced in-field and is not liable for travel costs for service work. In the event of in-home repair work, the customer will pay any in-home travel fees or service charges required by the Authorized Dealer.
28. At no time will Sherwood Industries Ltd. be liable for any consequential damages which exceed the purchase price of the unit. Sherwood Industries Ltd. has no obligation to enhance or modify any stove once manufactured (example: as a stove evolves, field modifications or upgrades will not be performed).
29. This Limited Warranty is applicable only to the original purchaser and it is non-transferable.
30. This warranty only covers Enviro products that are purchased through an authorized Enviro dealer.
31. If for any reason any section of the Limited Warranty is declared invalid, the balance of the warranty remains in effect and all other clauses shall remain in effect.
32. The Limited Warranty is the only warranty supplied by Sherwood Industries Ltd., the manufacturer of the stove. All other warranties, whether express or implied, are hereby expressly disclaimed and purchaser's recourse is expressly limited to the Limited Warranty.
33. Sherwood Industries Ltd. and its employees or representatives will not assume any damages, either directly or indirectly, caused by improper usage, operation, installation, servicing or maintenance of this stove.
34. Sherwood Industries Ltd. reserves the right to make changes without notice. Please complete and mail the warranty registration card and have the installer fill in the installation data sheet in the back of the manual for warranty and future reference.
35. Sherwood Industries Ltd. is responsible for stocking parts for a maximum of seven (7) years after discontinuing the manufacture or incorporation of the item into its products. An exception to this would be if an OEM supplier is not able to supply a part.

# INSTALLATION DATA SHEET

The following information must be recorded by the installer for warranty purposes and future reference.

NAME OF OWNER:  
\_\_\_\_\_  
  
ADDRESS:  
\_\_\_\_\_  
\_\_\_\_\_  
\_\_\_\_\_  
  
PHONE: \_\_\_\_\_

NAME OF DEALER:  
\_\_\_\_\_  
  
ADDRESS:  
\_\_\_\_\_  
\_\_\_\_\_  
\_\_\_\_\_  
  
PHONE: \_\_\_\_\_

MODEL: \_\_\_\_\_  
SERIAL NUMBER: \_\_\_\_\_  
DATE OF PURCHASE: \_\_\_\_\_ (dd/mm/yyyy)  
DATE OF INSTALLATION: \_\_\_\_\_ (dd/mm/yyyy)  
 DIRECT VENT                       B-VENT  
 NATURAL GAS (NAT)               PROPANE(LPG)  
INLET GAS PRESSURE: \_\_\_\_\_ in WC  
MAIN BURNER ORIFICE: \_\_\_\_\_ # DMS  
PILOT ORIFICE # \_\_\_\_\_ OR \_\_\_\_\_ in diam.  
INSTALLER'S SIGNATURE:  
\_\_\_\_\_

NAME OF INSTALLER:  
\_\_\_\_\_  
  
ADDRESS:  
\_\_\_\_\_  
\_\_\_\_\_  
\_\_\_\_\_  
  
PHONE: \_\_\_\_\_

MANUFACTURED BY:  
SHERWOOD INDUSTRIES LTD.  
6782 OLDFIELD RD. SAANICHTON, BC, CANADA V8M 2A3  
www.enviro.com  
July 26, 2010  
C-12258